

LOW VOLTAGE AC DRIVES

Technical reference catalog

All-compatible drives for machine building



- Our goal is to make machine building faster and easier utilizing our offering of drives and services.
- In this technical catalog, we present the most typical LV drives used in machine building: the ACS380, ACS480, ACS580 and ACS880 series drives.

—

You base your business on efficiency and performance. You know that everything counts to make you more competitive. Our drives are made with all this in mind, empowering productivity and efficiency.

Technical reference catalog

All-compatible drives for machine building

| | |
|-----|--|
| 004 | APPLICATION DESCRIPTION |
| 008 | THE ALL-COMPATIBLE DRIVES PORTFOLIO |
| 016 | TECHNICAL DATA – SUMMARY |
| 024 | RATINGS, TYPES AND VOLTAGES |
| 058 | INSTALLATION DIRECTIONS |
| 060 | DIMENSIONS |
| 066 | DRIVE-BASED FUNCTIONAL SAFETY |
| 070 | FOR EXPLOSIVE ATMOSPHERES |
| 074 | APPLICATION CONTROL PROGRAMS |
| 076 | FIELDBUS AND INDUSTRIAL ETHERNET SOLUTIONS |
| 078 | CONTROL PANELS |
| 080 | ASSISTANT CONTROL PANEL |
| 082 | ABB ABILITY™ CONDITION MONITORING FOR DRIVES |
| 086 | ABB ABILITY™ DIGITAL POWERTRAIN |
| 088 | COMMISSIONING AND PROGRAMMING TOOLS |
| 090 | MOBILE TOOLS |
| 091 | HEAT, NOISE AND AIRFLOW |
| 104 | AMBIENT AND INSTALLATION CONDITIONS AND DERATINGS, FREE SPACE REQUIREMENTS |
| 116 | BRAKE CHOPPER AND RESISTOR |
| 125 | CHOOSING THE RIGHT TYPE OF FUSE |
| 149 | CIRCUIT BREAKER TABLE |
| 157 | MOTOR CABLES |
| 158 | MOTOR CABLE LENGTHS |
| 160 | DU/DT FILTERS |
| 164 | SINE FILTERS |
| 170 | EMC |
| 172 | HARMONIC MITIGATION |
| 174 | CONTROL UNIT – DEFAULT I/O CONNECTIONS |
| 182 | INPUT/OUTPUT, EXTENSION AND FEEDBACK MODULES FOR INCREASED CONNECTIVITY |
| 184 | ORDERING INFORMATION |
| 197 | CUSTOMIZING DRIVES |
| 198 | WE KEEP YOUR WORLD TURNING |
| 200 | ABB DRIVES LIFE CYCLE MANAGEMENT |

Technical reference guide for machine building

Our goal is to make machine building faster and easier utilizing our offering of drives and services. In this technical catalog, we present the most typical LV drives used in machine building: the ACS380, ACS480, ACS580 and ACS880 series drives. During drive selection, you save time, as the drives have many built-in features, simplifying the selection process.

A broad range of options provide easy extension to the drive's functionality. The simplicity carries on to the drive setup and commissioning. With a state-of-the-art user interface and drive design, installation and setup is made easy and optimal.



Automation Builder

See pages 14-15



HMI

Safety PLC

PLC

I/O extension
- Optional

I/O interface
• Standard
See pages 174-181

Fieldbus interface
• Standard or optional
See pages 76-77

Functional safety
• STO as standard
• Advanced safety functionality optional
See pages 66-69

Control interface

Fusing and circuit breakers
See pages 125-148,
149-155

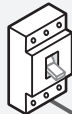

AC chokes
• Standard option
• External option



EMC filter
• Standard option
• External option
See pages 170-171



Supply network

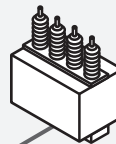

User and monitoring interface

Commissioning and programming tools
See pages 88-89

Remote monitoring tools
See pages 82-87

Remote monitoring tools



Control panels and mobile connectivity
See pages 78-80

Braking resistors
• External option
See pages 116-124



du/dt filter or sine filters
• External option
See pages 160-163



Speed feedback
• Optional



Induction motors
High efficiency motors
High output motors
Synchronous reluctance motors
Permanent magnet motors
High speed motors

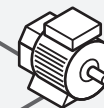

Motor control capability

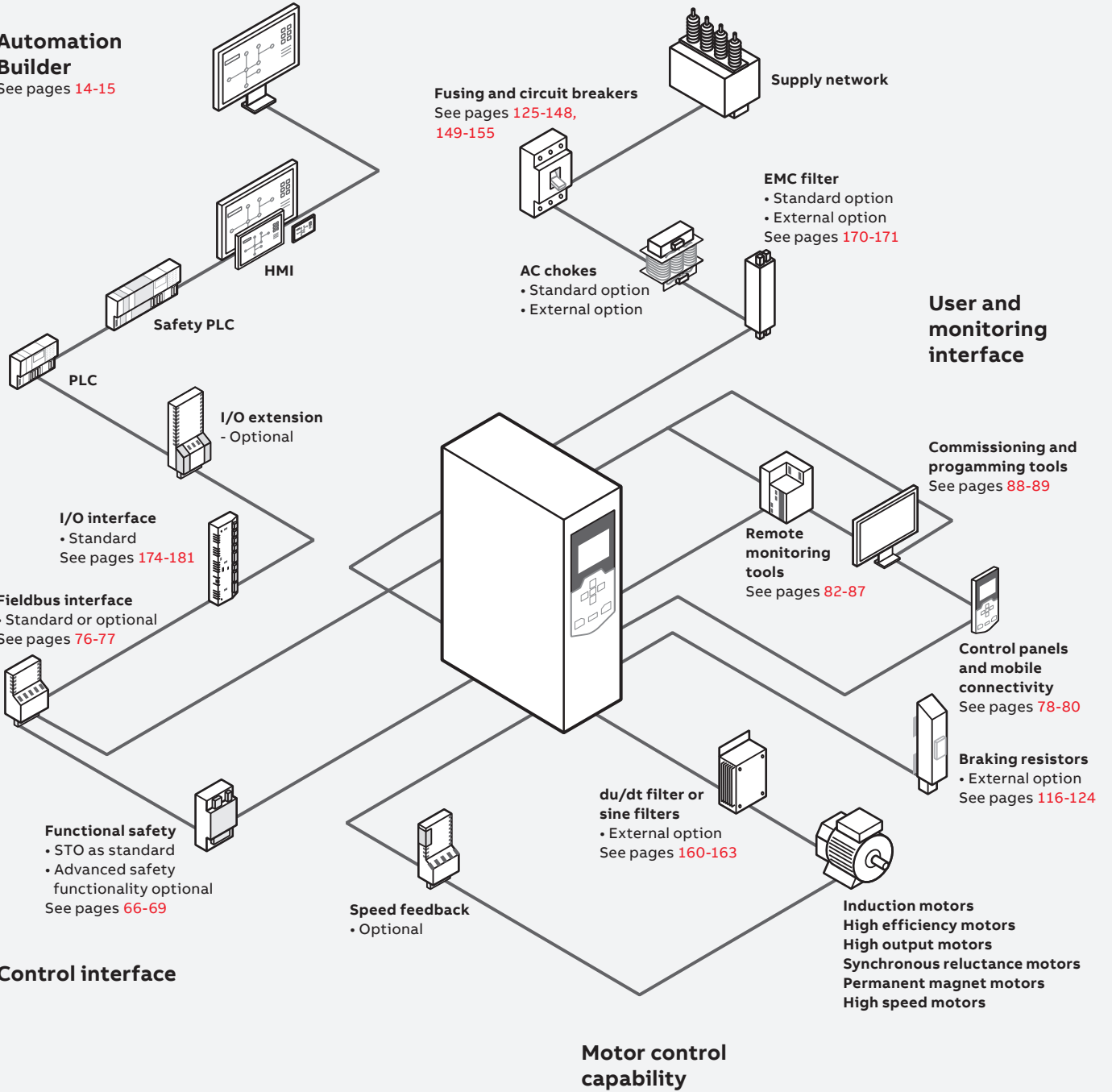

Complete ABB offering for machine building



Variable speed drives

Widest selection with scalable possibilities.

- Boosts productivity and energy efficiency, and cuts maintenance costs
- Scalable drives portfolio from micro, machinery and general purpose drives, to industrial drives and industry-specific drives
- Available directly from stock or can be built to order to meet more complex requirements
- Life cycle services to ensure exact operation of the processes, year after year



Motors

For optimal application control.

- Wide range of low voltage and medium voltage motors
- Reaches efficiency and energy saving levels even under the most demanding conditions
- Designed to operate reliably with low life cycle costs



ACS880 for speed, torque or position control

For almost any power and application.

- High accuracy and advanced functionality for wide power range and several variants. Ideal solution for almost any application from positioning applications like stacker cranes, metal presses, rotary tables and cutting systems to demanding open loop applications like winches
- Same user interface and hardware for the positioning controlled and the speed/torque controlled drives simplifying the engineering and use
- Ready made, embedded motion control functions eliminating the need for external position controllers

Performance

Efficiency

Accuracy



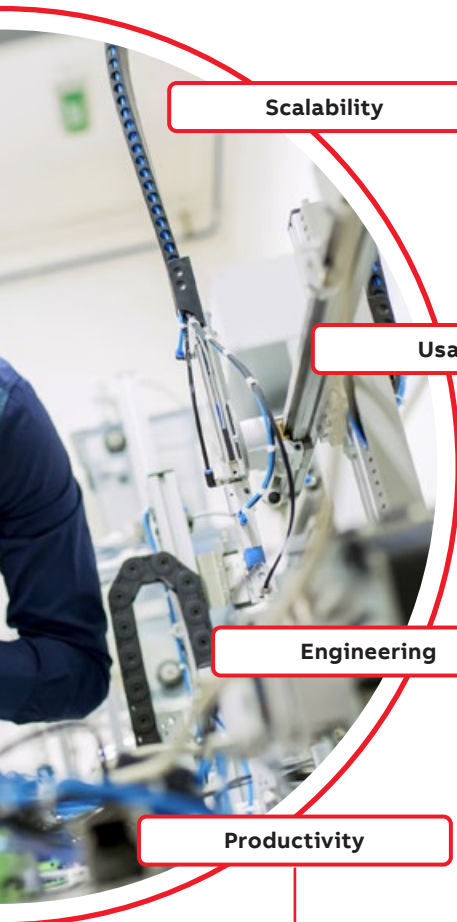

Scalability

Programmable Logic Controllers PLCs

For high performance and flexibility.

- The AC500-eCo, AC500, AC500-XC and AC500-S scalable PLC ranges provide solutions for small, medium and high-end applications
- The AC500 PLC platform offers different performance levels and is the ideal choice for high availability, extreme environments, condition monitoring, motion control or safety solutions



Usability

HMI (human-machine-interface)

Clear in touch with productivity.

- CP600-eCo, CP600 and CP600-Pro control panels offer a wide range of features and functionalities for maximum operability
- ABB control panels are distinguished by their robustness and easy usability, providing all the relevant information from production plants and machines at one single touch
- Easy remote access to HMI devices via mobile devices like smart phones



Engineering

ABB Ability™ Automation Builder

- Is the integrated software suite for machine builders and system integrators requiring state-of-the-art productive machine and system automation
- Combines the tools required for configuring, programming, debugging and maintaining automation projects from one common intuitive interface



Productivity

Robotics

For improved productivity, quality and worker safety.

- Industrial robots and robot software
- Robot equipment and complete application solutions
- Supported by the broadest service network and offering in the industry



The all-compatible drives portfolio



The idea behind our all-compatible drives portfolio is simple: the better a drive and provided services fit your processes, users, business and environmental goals, the faster you start enjoying the benefits it brings and the return on investment. The foundation of the all-compatible drives portfolio is in its architecture. The drives share the same software platform, tools, user interfaces and options. Yet, there is an optimal drive from the smallest water pump to the biggest cement kiln, and everything in between. When you have learned to use one drive, it is easy use the other drives in the portfolio. Already, our all-compatible portfolio offers a broad selection of drives and services. The offering keeps on growing, delivering more flexibility to meet your exact needs and simplicity to help manage your installed base. Locally and globally, now and in the future.

Learn it once, use it everywhere

If an application requires more than a specific drive type, the common drives architecture enables a smooth transition to other all-compatible drives in the ABB portfolio, such as the ACS380 machinery drives, ACS480 and ACS580 general purpose drives or ACS880 industrial drives. The drives share similar user interfaces and options, enabling operators to apply the same knowledge gained with other all-compatible drives.

All-compatible machinery drives, ACS380 series

Reliable performance and ease of integration for machine builders



► 0.25-22 kW ACS380 cabinet-mounted drives

The ACS380 machinery drive is ideal for machine building thanks to its excellent motor control, long-lasting design and connectivity with all major industrial automation networks. The ACS380 drive has many advanced features built-in as standard. A selection of variants and options allow the drive to be optimized for various fieldbus communication, I/O and EMC requirements. With the integrated functional safety features, the ACS380 drive can be part of the machine's safety system. The drive is easy to adapt for various machines thanks to its good programmability. Design features including coated circuit boards, minimized airflow through the electronics, and up to 50 °C operating temperature without derating make the ACS380 a safe choice for customers expecting high reliability. This is further enhanced by a full load test that is carried out on every single drive during production. The drive is suitable for industries such as food and beverage, material handling and textile. Examples of typical ACS380 applications are mixers, conveyors, extruders, cranes and textile machinery.

Highlights

- Excellent motor control for various motor types including induction, permanent magnet and synchronous reluctance motors
- Motor control performance with 3-phase current measurement meets demanding load profile requirements
- Connects with all major industrial automation systems
- Safe torque off (STO) is built-in as a standard, and can be controlled via PROFIsafe with an optional module
- Adaptive programming for customizing the drive for a wide range of applications
- Designed to last 10 years or more
- Part of ABB all-compatible drives portfolio

All-compatible general purpose drives, ACS480 and ACS580

Automation, simplicity and productivity



- ▶ 0.75-22 kW ACS480-04 drive modules
- ▶ 0.75-250 kW ACS580-01 wall-mounted drives
- ▶ 250-500 kW ACS580-04 drive modules
- ▶ 75-500 kW ACS580-07 cabinet-built drives

The low voltage ACS580 and ACS480 drive series are part of ABB's all-compatible drives portfolio. The drives' built-in features and compact design provide effortless automation, simplicity and productivity for a wide range of applications. Most essential features and software functions are built-in, simplifying drive selection, and making additional hardware unnecessary. With the ACS580 you can easily take full control of your processes and comprehensively manage your plant, while the ACS480 offers you a compact design for a cost-effective and efficient solution. These drives ensure ease of process automation and they are plug-in ready to control compressors, conveyors, pumps, mixers, extruders and many other variable- and constant-torque applications in many industries, including food and beverage, logistics and warehousing, agriculture, textile and automotive.

Highlights

- Effortless operation with assistant control panel and possibility to operate and monitor the drive via mobile phone with the Bluetooth control panel
- Primary settings and control macros for quick product set-up and help button for supporting in unclear situations
- All the essential features are built-in to simplify motor control and automate processes
- Adaptive programming to further cater application needs
- Vector and scalar control for accurate and energy efficient process control
- Safe torque off (STO) for implementing safe machinery available in the ACS580 and ACS480, and safe stopping functions (STO or SS1-t) through PROFIsafe as option for the ACS580
- ACS580's second-generation DC choke technology mitigates harmonics at no additional charge
- Built-in EMC filter fulfills standard C2 (ACS480 and ACS580 R1-R9) (1st env. public LV networks) and C3 (ACS580 R10-R11)
- Brake chopper as standard up to 22 kW
- Modbus RTU (EIA-485) as standard
- ACS480 for cabinet installations in IP20
- ACS580-01 for wall installations in IP21 and IP55

All-compatible industrial drives, ACS880 series

Uncompromised productivity



- ▶ 0.55-250 kW ACS880-01
wall-mounted drives
- ▶ 200-1200 kW ACS880-04 ^{*)}
single drive modules
- ▶ 45-710 kW ACS880-07 ^{*)}
cabinet-built single drives
- ▶ 4-110 kW ACS880-11
wall mounted regenerative drives
- ▶ 132-400 kW ACS880-14
regenerative drive modules
- ▶ 55-xx kW ACS880-17
cabinet built regenerative drives
- ▶ 4-110 kW ACS880-31
wall mounted ultra low harmonic drives
- ▶ 132-400 kW ACS880-34
ultra low harmonic drive modules
- ▶ 55-xx kW ACS880-37
cabinet built ultra low harmonic drives

The low voltage ACS880 industrial drive series are compatible with virtually all of your processes, automation systems, users and business requirements. The extensive power and voltage range, high flexibility and performance as well as the long life time and robust design make ACS880 drives the optimal choice for almost any application. The ACS880 series consists of single drives, drive modules and multidrives including ultra low harmonic drive and regenerative drive variants.

Highlights

- Wide power and voltage range – from 0.55 to 6000 kW and 200 to 690 V
- Extensive functional safety offering
- Compatible with virtually all AC motors including permanent magnet and highly efficient synchronous reluctance motors
- Premium motor control with DTC giving e.g. accurate speed and torque control throughout the speed range even without a feedback device
- Connectivity to all automation networks and remote monitoring solutions
- Wide range of built-in and optional features
- Ready-made application control programs
- Programming flexibility with easy-to-use tools
- Drive application programming based on IEC 61131-3
- Fully integrated and compact ultra low harmonic drives offering easy solution with almost non existing line side harmonics
- Fully integrated and compact regenerative drives for offering an energy saving solution for applications requiring frequent and/or high power braking
- Robust and long life time design with 9 year maintenance interval
- Memory unit for fast and easy drive replacement

^{*)} For higher power range, please contact ABB.

PLC Automation product family

Overview

Engineering suite



ABB Ability™ Automation Builder

- Automation Builder connects the engineering tools for PLC, safety, control panels, SCADA, drives and motion.
- Automation Builder combines the tools required for configuring, programming, debugging and maintaining automation projects from one common intuitive interface.



Library packages

- For efficient engineering of demanding applications.
- Easy-to-use application examples.

Visualization



CP600-eCo

- The economical CP600-eCo control panel is aimed for standard functions and high usability for clear interaction with the operation process.

Programmable Logic Controllers PLCs



AC500-eCo

- Compact PLC offering optimally suited flexible and economical configurations for automation solutions in smaller applications.
- ABB's AC500-eCo has been designed to integrate seamlessly into the broader AC500 PLC platform.

I/O modules



S500-eCo

- Range of modular I/Os for economical configurations in smaller applications.
- The I/O modules can be connected directly to the AC500 or AC500-eCo CPU modules.
- S500-eCo I/O modules can be mixed with standard S500 modules and also used as remote I/O with fieldbus communication interface modules.

**CP600**

- The robust CP600 HMI provides high visualization performance, versatile communication and representative design for machines and systems.

**CP600-Pro**

- The CP600-Pro HMI portfolio comes with high end visualization performance, multi-touch operation, versatile trendsetting communication and representative design.

**CP600-Pro**

- Control panels CP6607...CP6615 can be used to alter functional safety control functions in industrial applications.

**AC500**

- Powerful PLC featuring a wide range of performance, communications and I/O capabilities for industrial applications.
- The ideal choice for complex, high-speed machinery and networking solutions.

**AC500-XC**

- Extreme condition PLC variant of the AC500 platform.
- With extended operating temperature, immunity to vibration and hazardous gases, use at high altitudes and in humid environments.

**AC500-S**

- Integrated safety PLC (SIL3, PL e) designed for safety applications involved in factory, machinery or process automation area.
- For simple and complex safety solutions.

**S500**

- Modular I/O assortment with protected outputs and comprehensive diagnosis, covering a wide range of signal types.
- The I/O modules can be installed as remote I/O with a communication interface module or be directly connected to the AC500 CPU.
- Support of different fieldbuses makes it possible to use the S500 I/O modules with PLCs from different manufacturers.

**S500-XC**

- Extreme condition variant of the S500 I/O system.
- With extended operating temperature, immunity to vibration and hazardous gases, use at high altitudes and in humid environments.

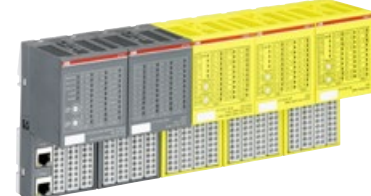
**S500-S**

- Safety variant of the S500 I/O system.
- Extreme condition variants available.

Technical data – summary



| Technical features | ACS380-04 | ACS480-04 | ACS580-01 | ACS580-04 | ACS580-07 |
|---|--|--|------------------------|----------------|----------------|
| Main connection | | | | | |
| Voltage (V) | 1~ 200-240 3~ 200-240 3~ 380-480 | 1~ 200-240 3~ 200-240 3~ 380-480 | 3~ 380-480 | 3~ 380-480 | 3~ 380-480 |
| Tolerance (%) | +10/-15 | +10/-15 | +10/-15 | +10/-15 | +10/-15 |
| Power range (kW) | 0.25-22 | 0.25-22 | 0.75-250 | 250-500 | 75-500 |
| IP classes | | | | | |
| IP00 | – | – | – | Standard | – |
| IP20 | Standard | Standard | – | Option (+B051) | – |
| IP21 | – | – | Standard | – | Standard |
| IP22 | – | – | – | – | – |
| IP42 | – | – | – | – | Option (+B054) |
| IP54 | – | – | – | – | Option (+B055) |
| IP55 | – | – | Option (+B056) | – | – |
| Installation | | | | | |
| Wall-mounted | – | – | Standard | – | – |
| Module to be built into a cabinet | Standard | Standard | – | Standard | – |
| Cabinet-built (including the module and the cabinet as a ready made solution) | ● | ● | ● | ● | Standard |
| Side-by-side (bookshelf) | ● | ● | ● | – | ● |
| Flange (the drive is installed from a flange onto a cabinet wall, heatsink is outside of the cabinet) | – | – | ● | – | – |
| Flat-mounted (the drive is rotated 90 degrees vertically) | – | – | – | – | – |
| Horizontal (the drive is installed horizontally) | ● | ● | ● | ● | – |
| Standard input/output^{*)} | | | | | |
| Digital input (DI) | 4 x DI | 6 x DI | 6 x DI | 6 x DI | 6 x DI |
| Digital input/output (DIO) | 2 x DIO | – | – | – | – |
| Analog input (AI) | 2 x AI | 2 x AI | 2 x AI | 2 x AI | 2 x AI |
| Analog output (AO) | 1 x AO | 2 x AO | 2 x AO | 2 x AO | 2 x AO |
| Relay outputs (RO) | 1 x RO | 3 x RO | 3 x RO | 3 x RO | 3 x RO |
| ^{*)} I/O features on the page 174 | | | | | |
| Fieldbus^{*)} | | | | | |
| Modbus RTU | | | Standard ¹⁾ | | |
| EtherNet/IP | ● | ● | ● | ● | ● |
| PROFINET | ● | ● | ● | ● | ● |
| EtherCAT | ● | ● | ● | ● | ● |
| CANopen | ● | ● | ● | ● | ● |
| POWERLINK | ● | ● | ● | ● | ● |
| ControlNet | ● | ● | ● | ● | ● |
| DeviceNet | ● | ● | ● | ● | ● |
| Modbus TCP | ● | ● | ● | ● | ● |
| PROFIBUS | ● | ● | ● | ● | ● |
| PROFIsafe | ● | – | ● | ● | ● |

^{*)} Optional fieldbus offering on the page 77

¹⁾ Modbus RTU as standard only in ACS380 standard variant (ACS380-04xS), for configurable variant (ACS380-04xC) multiple fieldbus options.

- Available as an option
- Not available



| Technical features | ACS880-01 | ACS880-04 | ACS880-04F | ACS880-04FXT | ACS880-04XT | ACS880-07 | ACS880-11/31 | ACS880-14/34 | ACS880-17/37 | |
|---|---|---|---|---|---|---|---|---|---|---|
| Main connection | | | | | | | | | | |
| Voltage (V) | 3 ~ 208-240 3 ~ 380-425 3 ~ 380-500 | 3 ~ 380-415 3 ~ 380-500 3 ~ 525-690 | 3 ~ 380-415 3 ~ 380-500 3 ~ 525-690 | 3 ~ 380-415 3 ~ 380-500 3 ~ 525-690 | 3 ~ 380-415 3 ~ 380-500 3 ~ 525-690 | 3 ~ 380-415 3 ~ 380-500 3 ~ 525-690 | 3 ~ 380-415 3 ~ 380-500 3 ~ 525-690 | 3 ~ 380-415 3 ~ 380-500 3 ~ 525-690 | 3 ~ 380-415 3 ~ 380-500 3 ~ 525-690 | 3 ~ 380-415 3 ~ 380-500 3 ~ 525-690 |
| Tolerance (%) | +10/-15 | +10/-15 | +10/-15 | +10/-15 | +10/-15 | +10/-10 | +10/-15 | +10/-15 | +10/-15 | ±10 |
| Power range (kW) | 0.55-250 | 250-710 | 250-710 | 560-1200 | 560-1200 | 45-710 | 2.2 to 110 | 110 to 400 | 110 to 400 | 45 to 400 |
| IP classes | | | | | | | | | | |
| IP00 | - | - | - | Standard | Standard | - | - | - | - | - |
| IP20 | Option (+P944) | Standard | Front side (standard) | ● | - | - | ● | Standard | - | - |
| IP21 | Standard | - | - | - | - | - | Standard | - | - | - |
| IP22 | - | - | - | - | - | Standard | - | - | - | Standard |
| IP42 | - | - | - | - | - | Option (+B054) | - | - | - | Option (+B054) |
| IP54 | - | - | - | - | - | Option (+B055) | - | - | - | Option (+B055) |
| IP55 | Option (+B056) | - | Heat sink side (standard) | - | - | - | ● | - | - | - |
| Installation | | | | | | | | | | |
| Wall-mounted | Standard | - | - | - | - | - | Standard | - | - | - |
| Module to be built into a cabinet | - | Standard | Standard | Standard | Standard | - | - | Standard | - | - |
| Cabinet-built (including the module and the cabinet as a ready made solution) | ● | ● | ● | - | - | Standard | ● | ● | Standard | - |
| Side-by-side (bookshelf) | ● | ● | ● | - | ● | ● | ● | ● | - | - |
| Flange (the drive is installed from a flange onto a cabinet wall, heatsink is outside of the cabinet) | ● | - | ● | ● | - | - | ● | - | - | - |
| Flat-mounted (the drive is rotated 90 degrees vertically) | - | ● | - | - | ● | - | - | - | - | - |
| Horizontal (the drive is installed horizontally) | ● | ● | - | - | - | - | ● | - | - | - |
| Standard input/output^{*)} | | | | | | | | | | |
| Digital input (DI) | 6 x DI | 6 x DI | 6 x DI | 6 x DI | 6 x DI | 6 x DI | 6 x DI | 6 x DI | 6 x DI | 6 x DI |
| Digital input/output (DIO) | 2 x DIO | 2 x DIO | 2 x DIO | 2 x DIO | 2 x DIO | 2 x DIO | 2 x DIO | 2 x DIO | 2 x DIO | 2 x DIO |
| Analog input (AI) | 2 x AI | 2 x AI | 2 x AI | 2 x AI | 2 x AI | 2 x AI | 2 x AI | 2 x AI | 2 x AI | 2 x AI |
| Analog output (AO) | 2 x AO | 2 x AO | 2 x AO | 2 x AO | 2 x AO | 2 x AO | 2 x AO | 2 x AO | 2 x AO | 2 x AO |
| Relay outputs (RO) | 3 x RO | 3 x RO | 3 x RO | 3 x RO | 3 x RO | 3 x RO | 3 x RO | 3 x RO | 3 x RO | 3 x RO |
| ^{*)} I/O features on the page 174 | | | | | | | | | | |
| Fieldbus^{*)} | | | | | | | | | | |
| Modbus RTU | Standard ¹⁾ | | | | | | | | | |
| EtherNet/IP | ● | ● | ● | ● | ● | ● | ● | ● | ● | ● |
| PROFINET | ● | ● | ● | ● | ● | ● | ● | ● | ● | ● |
| EtherCAT | ● | ● | ● | ● | ● | ● | ● | ● | ● | ● |
| CANopen | ● | ● | ● | ● | ● | ● | ● | ● | ● | ● |
| POWERLINK | ● | ● | ● | ● | ● | ● | ● | ● | ● | ● |
| ControlNet | ● | ● | ● | ● | ● | ● | ● | ● | ● | ● |
| DeviceNet | ● | ● | ● | ● | ● | ● | ● | ● | ● | ● |
| Modbus TCP | ● | ● | ● | ● | ● | ● | ● | ● | ● | ● |
| PROFIBUS | ● | ● | ● | ● | ● | ● | ● | ● | ● | ● |
| PROFIsafe | ● | ● | ● | ● | ● | ● | ● | ● | ● | ● |

^{*)} Optional fieldbus offering on the page 77

¹⁾ Modbus RTU as standard only in ACS380 standard variant (ACS380-04xS), for configurable variant (ACS380-04xC) multiple fieldbus options.

● Available as an option

- Not available

Technical data – summary



| Technical features | ACS380-04 | ACS480-04 | ACS580-01 | ACS580-04 | ACS580-07 |
|---------------------------------------|-------------------------|-----------|---|-----------------|-----------------|
| Safety options^{*)} | | | | | |
| Safe torque off (STO) | SIL 3 / PL e (standard) | | | | |
| Safe stop 1 (SS1-t) | FSPS-21 (+Q986) | – | FSPS-21 (+Q986) | FSPS-21 (+Q986) | FSPS-21 (+Q986) |
| Safe stop 1 (SS1-r) | – | – | – | – | – |
| Safe stop emergency (SSE) | – | – | – | – | – |
| Safe brake control (SBC) | – | – | – | – | – |
| Safely-limited speed (SLS) | – | – | – | – | – |
| Safe max. speed (SMS) | – | – | – | – | – |
| Safe direction (SDI) | – | – | – | – | – |
| Safe speed monitoring (SSM) | – | – | – | – | – |
| Safe motor temperature (SMT) | – | – | – | – | – |
| ATEX-certified STO | – | – | – | – | – |
| ATEX approved motor and drive package | – | – | Valid with ABB's Ex motors | | |
| ATEX approved thermistor input | – | – | ● CPTC-02 (+L537 +Q971) ^{***)} | | |

^{*)} Optional safety offering on the page 67

^{***)} ATEX classification: Ex II (2) GD

| EMC compatibility classes ^{*)} | | | | | |
|---|----------------------|----------------------|---|---|---|
| C1 | With external filter | With external filter | Option +E223 Up to R5 IP55 | – | – |
| C2 (excluding 690 V) | Configurable | Standard AC | Standard | – | Standard (up to 250 kW) |
| C3 | Configurable | – | – | Standard | Option (250-500 kW) |
| C4 | Configurable | – | – | – | – |
| Supply harmonics level and mitigation | No mitigation | No mitigation | DC or AC choke (typical THD(I) approx. 40%) | DC or AC choke (typical THD(I) approx. 40%) | DC or AC choke (typical THD(I) approx. 40%) |

^{*)} For more information on the page 170

Opt = Available as an option, Std = standard

| Electrical braking | | | | | |
|--------------------------------------|------------|------------|------------------------|---|---|
| Embedded braking chopper as standard | All frames | All frames | R1-R3 (up to 22 kW) | – | – |
| Built-in braking chopper as option | – | – | – | – | – |
| External braking chopper as option | – | – | R4-R9 (30-250 kW) | – | – |
| Regenerative braking | – | – | – | – | – |

● Available as an option

– Not available



| Technical features | ACS880-01 | ACS880-04 | ACS880-04F | ACS880-04FXT | ACS880-04XT | ACS880-07 | ACS880-11/31 | ACS880-14/34 | ACS880-17/37 |
|--------------------|-----------|-----------|------------|--------------|-------------|-----------|--------------|--------------|--------------|
|--------------------|-----------|-----------|------------|--------------|-------------|-----------|--------------|--------------|--------------|

Safety options*)

| | | | | | | | | | |
|---------------------------------------|---|--|--|--|--|--|--|--|--|
| Safe torque off (STO) | SIL 3 / PL e (standard) | | | | | | | | |
| Safe stop 1 (SS1-t) | ● FSO-12 (+Q973) / FSO-21 (+Q972) / FSPS-21 (+Q986) | | | | | | | | |
| Safe stop 1 (SS1-r) | | | | | | | | | |
| Safe stop emergency (SSE) | | | | | | | | | |
| Safe brake control (SBC) | ● FSO-12 (+Q973) / FSO-21 (+Q972) | | | | | | | | |
| Safely-limited speed (SLS) | | | | | | | | | |
| Safe max. speed (SMS) | | | | | | | | | |
| Safe direction (SDI) | ● FSO-21 (+Q972) + FSE-31 (+L521) | | | | | | | | |
| Safe speed monitoring (SSM) | ● FSO-21 (+Q972) | | | | | | | | |
| Safe motor temperature (SMT) | ● FPTC-01 (+L536) | | | | | | | | |
| ATEX-certified STO | ● (+Q971) | | | | | | | | |
| ATEX approved motor and drive package | Valid with ABB's Ex motors | | | | | | | | |
| ATEX approved thermistor input | ● FPTC-02 (+L537 +Q971)**), ***) | | | | | | | | |

*) Optional safety offering on the page 67

**) ACS880-07/17/37 available with +Q971 +L513/+L514/+L537

***) ATEX classification: Ex II (2) GD

EMC compatibility classes*)

| | | | | | | | | | | |
|---------------------------------------|---|---|---|---|---|---|---|--|--|--|
| C1 | - | - | - | - | - | - | - | - | - | |
| C2 (excluding 690 V) | Option | Option | Option | Option | Option | Opt (400-500 V up to 1000 A) | Option | Option | Option | |
| C3 | Option | Option | Option | Option | Option | Opt (R6-R11) | Option | Option | Opt (R8) Std (R11) | |
| C4 | Standard | Standard | Standard | Standard | Standard | Standard | Standard | Standard | Standard | |
| Supply harmonics level and mitigation | DC or AC choke (typical THD(I) approx. 40%) | DC or AC choke (typical THD(I) approx. 40%) | DC or AC choke (typical THD(I) approx. 40%) | DC or AC choke (typical THD(I) approx. 40%) | DC or AC choke (typical THD(I) approx. 40%) | DC or AC choke (typical THD(I) approx. 40%) | DC or AC choke (typical THD(I) approx. 40%) | Integrated ultra low harmonic operation (typical THD(I): < 3%) | Integrated ultra low harmonic operation (typical THD(I): < 3%) | Integrated ultra low harmonic operation (typical THD(I): < 3%) |

*) For more information on the page 170

Opt = Available as an option, Std = standard

Electrical braking

| | | | | | | | | | |
|--------------------------------------|-------------------------|--------------------|--------------------|--------------------|--------------------|---------------------------|-------------------------------------|-------------------------------------|--|
| Embedded braking chopper as standard | R1-R4 (up to 45 kW) | - | - | - | - | - | - | - | - |
| Built-in braking chopper as option | R5-R9 (55-250 kW +D150) | All frames (+D150) | All frames (+D150) | All frames (+D150) | All frames (+D150) | All frames (+D150, +D151) | - | - | ACS880-17: - ACS880-37: All frames (+D150, +D151) |
| External braking chopper as option | - | - | - | - | - | - | Coming later | ● | - |
| Regenerative braking | - | - | - | - | - | - | ACS880-11: Standard ACS880-31: - | ACS880-14: Standard ACS880-34: - | ACS880-17: Standard ACS880-37: - |

● Available as an option

- Not available

Technical data – summary



| Technical features | ACS380-04 | ACS480-04 | ACS580-01 | ACS580-04 | ACS580-07 |
|--|-------------|-------------|-------------|-------------|-------------|
| Motor control | | | | | |
| DTC | – | – | – | – | – |
| Vector control | ● | ● | ● | ● | ● |
| Scalar control | ● | ● | ● | ● | ● |
| Support for encoder feedback | ● | – | – | – | – |
| Filters | | | | | |
| Du/dt filters | ● | ● | ● | ● | ● |
| Sine filter support | ● | ● | ● | ● | – |
| Motor cable connection^{*)} | | | | | |
| Operational functionality and motor cable | Up to 150 m | Up to 150 m | Up to 300 m | Up to 300 m | Up to 300 m |
| EMC compatibility and motor cable | Up to 50 m | Up to 50 m | Up to 150 m | – | – |
| Resistor cable (max. length) | 10 m | 10 m | 10 m | 10 m | 10 m |
| ^{*)} Cable length data tables on the page 158 | | | | | |
| Supported motor types (SynRM = Synchronous reluctance motors) | | | | | |
| Induction | ● | ● | ● | ● | ● |
| Permanent magnet | ● | ● | ● | ● | ● |
| SynRM | ● | ● | ● | ● | ● |
| Programming | | | | | |
| Adaptive programming | ● | ● | ● | ● | ● |
| Full scale PLC programmability (IEC61131) | – | – | – | – | – |
| Application control program | | | | | |
| Winder (+N5000) | – | – | – | – | – |
| Crane (+N5050) | – | – | – | – | – |
| Tower crane (+N5650) | – | – | – | – | – |
| Winch (+N5100) | – | – | – | – | – |
| Centrifuge (+N5150) | – | – | – | – | – |
| PCP Pump (+N5200) | – | – | – | – | – |
| ESP Pump (+N5600) | – | – | – | – | – |
| Rod pump (+N5250) | – | – | – | – | – |
| Test bench (+N5300) | – | – | – | – | – |
| Cooling towers (+N5350) | – | – | – | – | – |
| Override for tunnel ventilation (+N5450) | – | – | – | – | – |
| Spinning for textile (+N5500) | – | – | – | – | – |
| Application program | | | | | |
| Master/follower | – | – | – | – | – |
| Redundant fieldbus | – | – | – | – | – |
| Single wire PC tool connection over EtherNet | ● | ● | ● | ● | ● |

● Available as an option

– Not available



| Technical features | ACS880-01 | ACS880-04 | ACS880-04F | ACS880-04FXT | ACS880-04XT | ACS880-07 | ACS880-11/31 | ACS880-14/34 | ACS880-17/37 |
|--|--|--|--|--|--|--|--|--|--|
| Motor control | | | | | | | | | |
| DTC | ● | ● | ● | ● | ● | ● | ● | ● | ● |
| Vector control | – | – | – | – | – | – | – | – | – |
| Scalar control | ● | ● | ● | ● | ● | ● | ● | ● | ● |
| Support for encoder feedback | ● | ● | ● | ● | ● | ● | ● | ● | ● |
| Filters | | | | | | | | | |
| Du/dt filters | ● | ● | ● | ● | ● | ● | ● | ● | ● |
| Sine filter support | ● (Supports both DTC and scalar modes) | ● (Supports both DTC and scalar modes) | ● (Supports both DTC and scalar modes) | ● (Supports both DTC and scalar modes) | ● (Supports both DTC and scalar modes) | ● (Supports both DTC and scalar modes) | ● (Supports both DTC and scalar modes) | ● (Supports both DTC and scalar modes) | ● (Supports both DTC and scalar modes) |
| Motor cable connection*) | | | | | | | | | |
| Operational functionality and motor cable | Up to 300 m | Up to 500 m | Up to 500 m | Up to 500 m | Up to 500 m | Up to 500 m | Up to 300 m | Up to 500 m | Up to 300m (R8) Up to 500m (R11) |
| EMC compatibility and motor cable | Up to 150 m | Up to 100 m | – | Up to 100 m | Up to 100 m | Up to 100 m | Up to 150 m | Up to 150 m | Up to 150 m |
| Resistor cable (max. length) | 10 m | 10 m | 10 m | 10 m | 10 m | 10 m | – | – | – |
| *) Cable length data tables on the page 158 | | | | | | | | | |
| Supported motor types (SynRM = Synchronous reluctance motors) | | | | | | | | | |
| Induction | ● | ● | ● | ● | ● | ● | ● | ● | ● |
| Permanent magnet | ● | ● | ● | ● | ● | ● | ● | ● | ● |
| SynRM | ● | ● | ● | ● | ● | ● | ● | ● | ● |
| Programming | | | | | | | | | |
| Adaptive programming | ● | ● | ● | ● | ● | ● | ● | ● | ● |
| Full scale PLC programmability (IEC61131) | ● | ● | ● | ● | ● | ● | ● | ● | ● |
| Application control program | | | | | | | | | |
| Winder (+N5000) | ● | ● | ● | ● | ● | ● | – | – | – |
| Crane (+N5050) | ● | ● | ● | ● | ● | ● | ● | ● | ● |
| Tower crane (+N5650) | ● | ● | ● | – | – | – | ● | ● | – |
| Winch (+N5100) | ● | ● | – | ● | ● | ● | ● | ● | ● |
| Centrifuge (+N5150) | ● | ● | ● | – | – | – | – | – | ● |
| PCP Pump (+N5200) | ● | ● | ● | ● | ● | ● | ● | ● | ● |
| ESP Pump (+N5600) | ● | ● | ● | ● | ● | ● | ● | ● | ● |
| Rod pump (+N5250) | ● | ● | ● | – | – | – | ● | ● | – |
| Test bench (+N5300) | ● | ● | ● | ● | ● | ● | – | – | ● |
| Cooling towers (+N5350) | ● | ● | ● | – | – | ● | – | – | ● |
| Override for tunnel ventilation (+N5450) | ● | ● | ● | ● | ● | ● | ● | ● | – |
| Spinning for textile (+N5500) | ● | ● | ● | – | – | – | – | – | – |
| Application program | | | | | | | | | |
| Master/follower | ● | ● | ● | ● | ● | ● | ● | ● | ● |
| Redundant fieldbus | ● | ● | ● | ● | ● | ● | ● | ● | ● |
| Single wire PC tool connection over EtherNet | ● | ● | ● | ● | ● | ● | ● | ● | ● |

● Available as an option
 – Not available

Technical data – summary



| Technical features | ACS380-04 | ACS480-04 | ACS580-01 | ACS580-04 | ACS580-07 |
|---|--------------|--------------|--------------|--------------|--------------|
| Ratings, types and voltages | See page 24 | See page 26 | See page 28 | See page 30 | See page 30 |
| Weight and dimensions | See page 60 | See page 60 | See page 60 | See page 61 | See page 61 |
| Noise level | See page 91 | See page 92 | See page 93 | See page 93 | See page 93 |
| Heat dissipation | See page 91 | See page 92 | See page 93 | See page 93 | See page 93 |
| Air flow | See page 91 | See page 92 | See page 93 | See page 93 | See page 93 |
| Embedded chopper ohm min/max | See page 116 | See page 117 | See page 118 | *) | *) |
| Working ambient condition limits and derating table | See page 104 | See page 105 | See page 106 | See page 107 | See page 108 |
| Braking resistor table with suggestion type code | See page 116 | See page 117 | See page 118 | *) | *) |
| MMQ power cable showing the terminals | See page 158 | See page 158 | See page 158 | See page 159 | See page 159 |

*) For further information, please contact ABB.



| Technical features | ACS880-01 | ACS880-04 | ACS880-04F | ACS880-04FXT | ACS880-04XT | ACS880-07 | ACS880-11/31 | ACS880-14/34 | ACS880-17/37 |
|---|--------------|--------------|--------------|--------------|--------------|--------------|--------------|--------------|--------------|
| Ratings, types and voltages | See page 32 | See page 36 | See page 36 | See page 36 | See page 38 | See page 42 | See page 46 | See page 48 | See page 50 |
| Weight and dimensions | See page 62 | See page 63 | See page 63 | See page 63 | See page 63 | See page 63 | See page 64 | See page 64 | See page 64 |
| Noise level | See page 94 | See page 96 | See page 96 | See page 97 | See page 98 | See page 99 | See page 101 | See page 101 | See page 102 |
| Heat dissipation | See page 94 | See page 96 | See page 96 | See page 97 | See page 98 | See page 99 | See page 101 | See page 101 | See page 102 |
| Air flow | See page 94 | See page 96 | See page 96 | See page 97 | See page 98 | See page 99 | See page 101 | See page 101 | See page 102 |
| Embedded chopper ohm min/max | See page 119 | See page 121 | See page 122 | See page 123 | See page 123 | *) | *) | *) | See page 124 |
| Working ambient condition limits and derating table | See page 109 | See page 110 | See page 111 | See page 111 | See page 110 | See page 112 | See page 113 | See page 114 | See page 115 |
| Braking resistor table with suggestion type code | See page 119 | See page 121 | See page 122 | See page 123 | See page 123 | *) | *) | *) | See page 124 |
| MMQ power cable showing the terminals | See page 159 | See page 159 | See page 159 | See page 159 | See page 159 | See page 159 | See page 159 | See page 159 | See page 159 |

*) For further information, please contact ABB.



Ratings, types and voltages

ACS380, cabinet-mounted



ACS380

1-phase, $U_N = 200\text{ V}$ (range 200 to 240 V). The power ratings are valid at nominal voltage 200 V (0.25 to 3.0 kW).

| Drive type | Frame size | I_{IN} , 230 V | | Nominal ratings | | Light-duty use | | Heavy-duty use | | Max. output current I_{max} (A) |
|--------------------|------------|------------------|------------|-----------------|------------|----------------|---------------|----------------|---------------|--------------------------------------|
| | | Without choke | With choke | I_N (A) | P_N (kW) | I_{Ld} (A) | P_{Ld} (kW) | I_{Hd} (A) | P_{Hd} (kW) | |
| | | (A) | (A) | | | | | | | |
| ACS380-04xx-02A4-1 | R0 | 5.0 | 4.2 | 2.4 | 0.37 | 2.3 | 0.37 | 1.8 | 0.25 | 3.2 |
| ACS380-04xx-03A7-1 | R0 | 7.8 | 6.4 | 3.7 | 0.55 | 3.5 | 0.55 | 2.4 | 0.37 | 4.3 |
| ACS380-04xx-04A8-1 | R1 | 10.1 | 8.3 | 4.8 | 0.75 | 4.6 | 0.75 | 3.7 | 0.55 | 6.7 |
| ACS380-04xx-06A9-1 | R1 | 14.5 | 11.9 | 6.9 | 1.1 | 6.6 | 1.1 | 4.8 | 0.75 | 8.6 |
| ACS380-04xx-07A8-1 | R1 | 16.4 | 13.5 | 7.8 | 1.5 | 7.4 | 1.5 | 6.9 | 1.1 | 12.4 |
| ACS380-04xx-09A8-1 | R2 | 20.6 | 17.0 | 9.8 | 2.2 | 9.3 | 2.2 | 7.8 | 1.5 | 14.0 |
| ACS380-04xx-12A2-1 | R2 | 25.6 | 21.1 | 12.2 | 3.0 | 11.6 | 3.0 | 9.8 | 2.2 | 17.6 |

ACS380

$U_N = 400\text{ V}$ (range 380 to 480 V). The power ratings are valid at nominal voltage 400 V (0.37 to 22 kW).

| Drive type | Frame size | I_{IN} , 400 V | | Nominal ratings | | Light-duty use | | Heavy-duty use | | Max. output current I_{max} (A) |
|--------------------|------------|------------------|------------|-----------------|------------|----------------|---------------|----------------|---------------|--------------------------------------|
| | | Without choke | With choke | I_N (A) | P_N (kW) | I_{Ld} (A) | P_{Ld} (kW) | I_{Hd} (A) | P_{Hd} (kW) | |
| | | (A) | (A) | | | | | | | |
| ACS380-04xx-01A8-4 | R0 | 2.9 | 1.8 | 1.8 | 0.55 | 1.7 | 0.55 | 1.2 | 0.37 | 2.2 |
| ACS380-04xx-02A6-4 | R1 | 4.2 | 2.6 | 2.6 | 0.75 | 2.5 | 0.75 | 1.8 | 0.55 | 3.2 |
| ACS380-04xx-03A3-4 | R1 | 5.3 | 3.3 | 3.3 | 1.1 | 3.1 | 1.1 | 2.6 | 0.75 | 4.7 |
| ACS380-04xx-04A0-4 | R1 | 6.4 | 4.0 | 4.0 | 1.5 | 3.8 | 1.5 | 3.3 | 1.1 | 5.9 |
| ACS380-04xx-05A6-4 | R1 | 9.0 | 5.6 | 5.6 | 2.2 | 5.3 | 2.2 | 4 | 1.5 | 7.2 |
| ACS380-04xx-07A2-4 | R1 | 11.5 | 7.2 | 7.2 | 3 | 6.8 | 3 | 5.6 | 2.2 | 10.1 |
| ACS380-04xx-09A4-4 | R1 | 15.0 | 9.4 | 9.4 | 4 | 8.9 | 4 | 7.2 | 3 | 13 |
| ACS380-04xx-12A6-4 | R2 | 20.2 | 12.6 | 12.6 | 5.5 | 12 | 5.5 | 9.4 | 4 | 16.9 |
| ACS380-04xx-17A0-4 | R3 | 27.2 | 17.0 | 17 | 7.5 | 16.2 | 7.5 | 12.6 | 5.5 | 22.7 |
| ACS380-04xx-25A0-4 | R3 | 40.0 | 25.0 | 25 | 11 | 23.8 | 11 | 17 | 7.5 | 30.6 |
| ACS380-04xx-032A-4 | R4 | 45.0 | 32.0 | 32 | 15 | 30.5 | 15 | 25 | 11 | 45 |
| ACS380-04xx-038A-4 | R4 | 50.0 | 38.0 | 38 | 18.5 | 36 | 18.5 | 32 | 15 | 57.6 |
| ACS380-04xx-045A-4 | R4 | 56.0 | 45.0 | 45 | 22 | 42.8 | 22 | 38 | 18.5 | 68.4 |
| ACS380-04xx-050A-4 | R4 | 60.0 | 50.0 | 50 | 22 | 48 | 22 | 45 | 22 | 81 |

| Nominal ratings | |
|----------------------------------|--|
| I_N | Rated current available continuously without overloading at 50 °C. |
| I_{max} | Maximum output current. Available for 2 s at start. Note: max. motor shaft power is 150 % P_{Hd} . |
| Typical ratings: No-overload use | |
| P_N | Typical motor power in no-overload use. |
| Light-duty use | |
| I_{Ld} | Continuous current allowing 110 % I_{Ld} for 1 min/5 min at 50 °C. |
| P_{Ld} | Typical motor power in light-duty use. |
| Heavy-duty use | |
| I_{Hd} | Continuous current allowing 150 % I_{Ld} for 1 minute every 10 minutes at 50 °C. |
| P_{Hd} | Typical motor power in heavy-duty use. |

Ordering variants

| Connectivity type | |
|-------------------------|--|
| ACS380-04xN | Base drive unit |
| ACS380-04xS | I/O and Modbus -variant (contains I/O connection module) |
| ACS380-04xC | Configured variant (requires always a Fieldbus or I/O plus code) |
| ACS380-04xC-xxxx-x+K454 | PROFIBUS DP protocol configured |
| ACS380-04xC-xxxx-x+K495 | CANopen® protocol configured |
| ACS380-04xC-xxxx-x+K469 | EtherCAT® protocol configured |
| ACS380-04xC-xxxx-x+K457 | CANopen® protocol configured |
| ACS380-04xC-xxxx-x+K451 | DeviceNet variant |
| ACS380-04xC-xxxx-x+K470 | ETHERNET POWERLINK variant |
| ACS380-04xC-xxxx-x+K490 | FEIP-21 Ethernet/IP |
| ACS380-04xC-xxxx-x+K491 | FMBT-21 Modbus TCP |
| ACS380-04xC-xxxx-x+K492 | FPNO-21 PROFINET IO |
| ACS380-04xC-xxxx+Q986 | PROFIsafe over PROFINET with safe stopping functions |
| EMC filtering level | |
| ACS380-040x | EMC category C3 (400 V) or C4 (230 V) |
| ACS380-042x | EMC category C2 |

Ratings, types and voltages

ACS480-04, drive module



ACS480-04**3-phase, $U_N = 400$ V (range 380 to 480 V)**

| Drive type | Frame size | Input current | | Nominal ratings | | Light-duty use | | Heavy-duty use | | Max. output current I_{max} (A) |
|------------------|------------|---------------|------------|-----------------|------------|----------------|---------------|----------------|---------------|--------------------------------------|
| | | Without choke | With choke | I_N (A) | P_N (kW) | I_{Ld} (A) | P_{Ld} (kW) | I_{Hd} (A) | P_{Hd} (kW) | |
| | | I_1 (A) | I_1 (A) | | | | | | | |
| ACS480-04-02A7-4 | R1 | 4.2 | 2.6 | 2.6 | 0.75 | 2.5 | 0.75 | 1.8 | 0.55 | 3.2 |
| ACS480-04-03A4-4 | R1 | 5.3 | 3.3 | 3.3 | 1.1 | 3.1 | 1.1 | 2.6 | 0.75 | 4.7 |
| ACS480-04-04A1-4 | R1 | 6.4 | 4.0 | 4.0 | 1.5 | 3.8 | 1.5 | 3.3 | 1.1 | 5.9 |
| ACS480-04-05A7-4 | R1 | 9.0 | 5.6 | 5.6 | 2.2 | 5.3 | 2.2 | 4.0 | 1.5 | 7.2 |
| ACS480-04-07A3-4 | R1 | 11.5 | 7.2 | 7.2 | 3.0 | 6.8 | 3.0 | 5.6 | 2.2 | 10.1 |
| ACS480-04-09A5-4 | R1 | 15.0 | 9.4 | 9.4 | 4.0 | 8.9 | 4.0 | 7.2 | 3.0 | 13.0 |
| ACS480-04-12A7-4 | R2 | 20.2 | 12.6 | 12.6 | 5.5 | 12.0 | 5.5 | 9.4 | 4.0 | 16.9 |
| ACS480-04-018A-4 | R3 | 27.2 | 17.0 | 17.0 | 7.5 | 16.2 | 7.5 | 12.6 | 5.5 | 22.7 |
| ACS480-04-026A-4 | R3 | 40.0 | 25.0 | 25.0 | 11.0 | 23.8 | 11.0 | 17.0 | 7.5 | 30.6 |
| ACS480-04-033A-4 | R4 | 45.0 | 32.0 | 32.0 | 15.0 | 30.5 | 15.0 | 25.0 | 11.0 | 45.0 |
| ACS480-04-039A-4 | R4 | 50.0 | 38.0 | 38.0 | 18.5 | 36.0 | 18.5 | 32.0 | 15.0 | 57.6 |
| ACS480-04-046A-4 | R4 | 56.0 | 45.0 | 45.0 | 22.0 | 42.8 | 22.0 | 38.0 | 18.5 | 68.4 |
| ACS480-04-050A-4 | R4 | 60.0 | 50.0 | 50.0 | 22.0 | 48.0 | 22.0 | 45.0 | 22.0 | 81.0 |

Nominal ratings

| | |
|-----------|--|
| I_N | Rated current available continuously without overloading at 50 °C. |
| I_{max} | Maximum output current. Available for 2 s at start. Note: max. motor shaft power is 150 % P_{Hd} . |

Typical ratings: No-overload use

| | |
|-------|---|
| P_N | Typical motor power in no-overload use. |
|-------|---|

Light-duty use

| | |
|----------|--|
| I_{Ld} | Continuous current allowing 110 % I_{Ld} for 1 min/5 min at 50 °C. |
| P_{Ld} | Typical motor power in light-duty use. |

Heavy-duty use

| | |
|----------|--|
| I_{Hd} | Continuous current allowing 150 % I_{Ld} for 1 minute every 10 minutes at 50 °C. |
| P_{Hd} | Typical motor power in heavy-duty use. |

Ratings, types and voltages

ACS580-01, wall-mounted



3-phase, $U_N = 230$ V (range 200 to 240 V). The power ratings are valid at nominal voltage 230 V (0.75 to 75 kW)

| Drive type | Frame size | Nominal ratings | | Light-duty use | | Heavy-duty use | | Maximum output current I_{Max} (A) |
|------------------|------------|-----------------|------|----------------|---------------|----------------|---------------|---|
| | | I_N (A) | (kW) | I_{Ld} (A) | P_{Ld} (kW) | I_{Hd} (A) | P_{Hd} (kW) | |
| ACS580-01-04A7-2 | R1 | 4.7 | 0.75 | 4.6 | 0.75 | 3.5 | 0.55 | 6.3 |
| ACS580-01-06A7-2 | R1 | 6.7 | 1.1 | 6.6 | 1.1 | 4.6 | 0.75 | 8.9 |
| ACS580-01-07A6-2 | R1 | 7.6 | 1.5 | 7.5 | 1.5 | 6.6 | 1.1 | 11.9 |
| ACS580-01-012A-2 | R1 | 12 | 3 | 11.8 | 3 | 7.5 | 2.2 | 19.1 |
| ACS580-01-018A-2 | R1 | 16.9 | 4 | 16.7 | 4 | 10.6 | 3.0 | 22 |
| ACS580-01-025A-2 | R2 | 24.5 | 5.5 | 24.2 | 5.5 | 16.7 | 4.0 | 32.7 |
| ACS580-01-032A-2 | R2 | 31.2 | 7.5 | 30.8 | 7.5 | 24.2 | 5.5 | 43.6 |
| ACS580-01-047A-2 | R3 | 46.7 | 11 | 46.2 | 11 | 30.8 | 7.5 | 62.4 |
| ACS580-01-060A-2 | R3 | 60 | 15 | 59.4 | 15 | 46.2 | 11 | 83.2 |
| ACS580-01-089A-2 | R5 | 89 | 22 | 88 | 22 | 74.8 | 18.5 | 135 |
| ACS580-01-115A-2 | R5 | 115 | 30 | 114 | 30 | 88.0 | 22.0 | 158 |
| ACS580-01-144A-2 | R6 | 144 | 37 | 143 | 37 | 114 | 30 | 205 |
| ACS580-01-171A-2 | R7 | 171 | 45 | 169 | 45 | 143 | 37 | 257 |
| ACS580-01-213A-2 | R7 | 213 | 55 | 211 | 55 | 169 | 45 | 304 |
| ACS580-01-276A-2 | R8 | 276 | 75 | 273 | 75 | 211 | 55 | 380 |

Nominal ratings

| | |
|-------|--|
| I_N | Rated current available continuously without overloadability at 40 °C. |
| P_N | Typical motor power in no-overload use. |

Maximum output current

| | |
|-----------|---|
| I_{max} | Maximum output current. Available for 2 seconds at start, then as long as allowed by drive temperature. |
|-----------|---|

Light-overload use

| | |
|----------|---|
| I_{Ld} | Continuous current allowing 110% I_{Ld} for 1 minute every 10 minutes at 40 °C. |
| P_{Ld} | Typical motor power in light-overload use. |

The ratings apply for the frames R1 to R9 up to +40 °C in enclosed IP21/IP55.

For derating at high altitudes, temperatures or switching frequencies, see the user's HW manual, document code: 3AXD50000035866.

| ACS580-01 | | | | | | | | | | | | | | | |
|--------------------|------------|----------------------------------|-----------|----------------|---------------|----------------------|---------------|---------------------|----------------|--|----------------|---------------|---------------------|--|--|
| 3-phase, 380-480 V | | | | | | | | | | | | | | | |
| Drive type | Frame size | 3-phase, $U_N = 380, 400, 415$ V | | | | | | | | 3-phase, $U_N = 440, 460, 480$ V ¹⁾ | | | | | |
| | | Nominal ratings | | Light-duty use | | Heavy-duty use | | Max. output current | Light-duty use | | Heavy-duty use | | Max. output current | | |
| | | P_N (kW) | I_N (A) | I_{Ld} (A) | P_{Ld} (kW) | I_{Hd} (A) | P_{Hd} (kW) | | I_{Ld} (A) | P_{Ld} (hp) | I_{Hd} (A) | P_{Hd} (hp) | | | |
| ACS580-01-02A7-4 | R1 | 0.75 | 2.6 | 2.5 | 0.75 | 1.8 | 0.55 | 3.2 | 2.1 | 1 | 1.6 | 0.75 | 2.9 | | |
| ACS580-01-03A4-4 | R1 | 1.1 | 3.3 | 3.1 | 1.1 | 2.6 | 0.75 | 4.7 | 3 | 1.5 | 2.1 | 1 | 3.8 | | |
| ACS580-01-04A1-4 | R1 | 1.5 | 4 | 3.8 | 1.5 | 3.3 | 1.1 | 5.9 | 3.5 | 2 | 3 | 1.5 | 5.4 | | |
| ACS580-01-05A7-4 | R1 | 2.2 | 5.6 | 5.3 | 2.2 | 4 | 1.5 | 7.2 | 4.8 | 3 | 3.4 | 2 | 6.1 | | |
| ACS580-01-07A3-4 | R1 | 3 | 7.2 | 6.8 | 3 | 5.6 | 2.2 | 10.1 | 6 | 3 | 4 | 3 | 7.2 | | |
| ACS580-01-09A5-4 | R1 | 4 | 9.4 | 8.9 | 4 | 7.2 | 3 | 13 | 7.6 | 5 | 4.8 | 3 | 8.6 | | |
| ACS580-01-12A7-4 | R1 | 5.5 | 12.6 | 12 | 5.5 | 9.4 | 4 | 14.1 | 12 | 7.5 | 7.6 | 5 | 11.4 | | |
| ACS580-01-018A-4 | R2 | 7.5 | 17 | 16.2 | 7.5 | 12.6 | 5.5 | 22.7 | 14 | 10 | 11 | 7.5 | 19.8 | | |
| ACS580-01-026A-4 | R2 | 11 | 25 | 23.8 | 11 | 17 | 7.5 | 30.6 | 23 | 15 | 14 | 10 | 25.2 | | |
| ACS580-01-033A-4 | R3 | 15 | 32 | 30.4 | 15 | 24.6 | 11 | 44.3 | 27 | 20 | 21 | 15 | 37.8 | | |
| ACS580-01-039A-4 | R3 | 18.5 | 38 | 36.1 | 18.5 | 31.6 | 15 | 56.9 | 34 | 25 | 27 | 20 | 48.6 | | |
| ACS580-01-046A-4 | R3 | 22 | 45 | 42.8 | 22 | 37.7 | 18.5 | 67.9 | 44 | 30 | 34 | 25 | 61.2 | | |
| ACS580-01-062A-4 | R4 | 30 | 62 | 58 | 30 | 44.6 | 22 | 76 | 52 | 40 | 40 | 30 | 76 | | |
| ACS580-01-073A-4 | R4 | 37 | 73 | 68.4 | 37 | 61 | 30 | 104 | 65 | 50 | 52 | 40 | 104 | | |
| ACS580-01-088A-4 | R5 | 45 | 88 | 82.7 | 45 | 72 | 37 | 122 | 77 | 60 | 65 | 50 | 122 | | |
| ACS580-01-106A-4 | R5 | 55 | 106 | 100 | 55 | 87 | 45 | 148 | 96 | 75 | 77 | 60 | 148 | | |
| ACS580-01-145A-4 | R6 | 75 | 145 | 138 | 75 | 105 | 55 | 178 | 124 | 100 | 96 | 75 | 178 | | |
| ACS580-01-169A-4 | R7 | 90 | 169 | 161 | 90 | 145 | 75 | 247 | 156 | 125 | 124 | 100 | 247 | | |
| ACS580-01-206A-4 | R7 | 110 | 206 | 196 | 110 | 169 | 90 | 287 | 180 | 150 | 156 | 125 | 287 | | |
| ACS580-01-246A-4 | R8 | 132 | 246 | 234 | 132 | 206 | 110 | 350 | 240 | 200 | 180 | 150 | 350 | | |
| ACS580-01-293A-4 | R8 | 160 | 293 | 278 | 160 | 246 ^{*)} | 132 | 418 | 260 | 200 | 240 | 150 | 418 | | |
| ACS580-01-363A-4 | R9 | 200 | 363 | 345 | 200 | 293 | 160 | 498 | 361 | 300 | 302 | 250 | 542 | | |
| ACS580-01-430A-4 | R9 | 250 | 430 | 400 | 200 | 363 ^{**)*)} | 200 | 545 | 414 | 350 | 361 | 300 | 542 | | |

Nominal ratings

| | |
|-----------|--|
| I_N | Rated current available continuously without overloading at 40 °C (104 °F). |
| I_{max} | Maximum output current. Available for 10 s at start, otherwise as long as allowed by drive temperature. Note: maximum motor shaft power is 150 % P_{Hd} . |

Typical ratings: No-overload use

| | |
|-------|---|
| P_N | Typical motor power in no-overload use. |
|-------|---|

Light-duty use

| | |
|----------|--|
| I_{Ld} | Continuous current allowing 110 % I_{Ld} for 1 minute every 10 minutes at 40 °C. |
| P_{Ld} | Typical motor power in light-duty use. |

Heavy-duty use

| | |
|----------|---|
| I_{Hd} | Continuous current allowing 150 % I_{Ld} for 1 minute every 10 minutes at 50 °C. ^{*)} Maximum current with 130 % overload, allowed for one minute every ten minutes. ^{**)*)} Maximum current with 125 % overload, allowed for one minute every ten minutes. |
| P_{Hd} | Typical motor power in heavy-duty use. |

¹⁾ The nominal ratings of ACS580-01 in 440, 460, 480 V range are identical with the light-duty values.

Ratings, types and voltages

ACS580-04, drive module

ACS580-07, cabinet-built



ACS580-04**3-phase, 380 to 480 V**

| Drive type | Frame size | 3-phase, $U_N = 380, 400, 415$ V | | | | | | | 3-phase, $U_N = 440, 460, 480$ V ¹⁾ | | | | |
|------------------|------------|----------------------------------|-----------|----------------|---------------|----------------|---------------|---------------------|--|--------------|----------------|--------------|---------------------|
| | | Nominal ratings | | Light-duty use | | Heavy-duty use | | Max. output current | Light-duty use | | Heavy-duty use | | Max. output current |
| | | P_N (kW) | I_N (A) | I_{Ld} (A) | P_{Ld} (kW) | I_{Hd} (A) | P_{Hd} (kW) | | I_{max} (A) | I_{Ld} (A) | P_{Ld} (hp) | I_{Hd} (A) | |
| ACS580-04-505A-4 | R10 | 250 | 505 | 485 | 250 | 361 | 200 | 560 | 483 | 400 | 361 | 300 | 560 |
| ACS580-04-585A-4 | R10 | 315 | 585 | 575 | 315 | 429 | 250 | 730 | 573 | 450 | 414 | 350 | 730 |
| ACS580-04-650A-4 | R10 | 355 | 650 | 634 | 355 | 477 | 250 | 730 | 623 | 500 | 477 | 400 | 730 |
| ACS580-04-725A-4 | R11 | 400 | 725 | 715 | 400 | 566 | 315 | 1020 | 705 | 600 | 566 | 450 | 850 |
| ACS580-04-820A-4 | R11 | 450 | 820 | 810 | 450 | 625 | 355 | 1020 | 807 | 700 | 625 | 500 | 1020 |
| ACS580-04-880A-4 | R11 | 500 | 880 | 865 | 500 | 725*) | 400 | 1100 | 807 | 700 | 625 | 500 | 1020 |

ACS580-07**3-phase, 380 to 480 V**

| Drive type | Frame size | 3-phase, $U_N = 380, 400, 415$ V | | | | | | | 3-phase, $U_N = 440, 460, 480$ V ¹⁾ | | | | |
|-------------------|------------|----------------------------------|-----------|----------------|---------------|----------------|---------------|---------------------|--|--------------|----------------|--------------|---------------------|
| | | Nominal ratings | | Light-duty use | | Heavy-duty use | | Max. output current | Light-duty use | | Heavy-duty use | | Max. output current |
| | | P_N (kW) | I_N (A) | I_{Ld} (A) | P_{Ld} (kW) | I_{Hd} (A) | P_{Hd} (kW) | | I_{max} (A) | I_{Ld} (A) | P_{Ld} (hp) | I_{Hd} (A) | |
| ACS580-07-0145A-4 | R6 | 75 | 145 | 138 | 75 | 105 | 55 | 178 | 124 | 100 | 96 | 75 | 178 |
| ACS580-07-0169A-4 | R7 | 90 | 169 | 161 | 90 | 145 | 75 | 247 | 156 | 125 | 124 | 100 | 247 |
| ACS580-07-0206A-4 | R7 | 110 | 206 | 196 | 110 | 169 | 90 | 287 | 180 | 150 | 156 | 125 | 287 |
| ACS580-07-0246A-4 | R8 | 132 | 246 | 234 | 132 | 206 | 110 | 350 | 240 | 200 | 180 | 150 | 350 |
| ACS580-07-0293A-4 | R8 | 160 | 293 | 278 | 160 | 246**) | 132 | 418 | 260 | 200 | 240 | 150 | 418 |
| ACS580-07-0363A-4 | R9 | 200 | 363 | 345 | 200 | 293 | 160 | 498 | 361 | 300 | 302 | 250 | 542 |
| ACS580-07-0430A-4 | R9 | 250 | 430 | 400 | 200 | 363***) | 200 | 617 | 414 | 350 | 361 | 300 | 542 |
| ACS580-07-0505A-4 | R10 | 250 | 505 | 485 | 250 | 361 | 200 | 560 | 483 | 400 | 361 | 300 | 560 |
| ACS580-07-0585A-4 | R10 | 315 | 585 | 575 | 315 | 429 | 250 | 730 | 573 | 450 | 414 | 350 | 730 |
| ACS580-07-0650A-4 | R10 | 355 | 650 | 634 | 355 | 477 | 250 | 730 | 623 | 500 | 477 | 400 | 730 |
| ACS580-07-0725A-4 | R11 | 400 | 725 | 715 | 400 | 566 | 315 | 1020 | 705 | 600 | 566 | 450 | 850 |
| ACS580-07-0820A-4 | R11 | 450 | 820 | 810 | 450 | 625 | 355 | 1020 | 807 | 700 | 625 | 500 | 1020 |
| ACS580-07-0880A-4 | R11 | 500 | 880 | 865 | 500 | 725*) | 400 | 1100 | 807 | 700 | 625 | 500 | 1020 |

Nominal ratings

| | |
|-----------|--|
| I_N | Rated current available continuously without overloading at 40 °C (104 °F). |
| I_{max} | Maximum output current. Available for 10 s at start, otherwise as long as allowed by drive temperature. Note: maximum motor shaft power is 150 % P_{Hd} . |

Typical ratings: No-overload use

| | |
|-------|---|
| P_N | Typical motor power in no-overload use. |
|-------|---|

Light-duty use

| | |
|----------|--|
| I_{Ld} | Continuous current allowing 110% I_{Ld} for 1 min/5 min at 40 °C (104 °F). |
| P_{Ld} | Typical motor power in light-duty use. |

Heavy-duty use

| | |
|----------|--|
| I_{Hd} | Continuous current allowing 150 % I_{Hd} for 1 min every 10 min at 40 °C. *) Continuous current allowing 130 % I_{Hd} for 1 min every 10 min at 40 °C. **) Continuous current allowing 125 % I_{Hd} for 1 min every 10 min at 40 °C. ***) Continuous current allowing 140 % I_{Hd} for 1 min every 10 min at 40 °C. |
| P_{Hd} | Typical motor power in heavy-duty use. |

¹⁾ The nominal ratings of ACS580-04 and ACS580-07 in 440, 460, 480 V range are identical with the light-duty values.

Ratings, types and voltages

ACS880-01, wall-mounted



ACS880-01 **$U_N = 230$ V (range 208 to 240 V). The power ratings are valid at nominal voltage 230 V (0.55 to 75 kW).**

| Drive type | Frame size | Nominal ratings | | Light-duty use | | Heavy-duty use | | Max. output current I_{MAX} (A) |
|------------------|------------------|-----------------|------------|----------------|---------------|----------------|---------------|--------------------------------------|
| | | I_N (A) | P_n (kW) | I_{Ld} (A) | P_{Ld} (kW) | I_{Hd} (A) | P_{Hd} (kW) | |
| ACS880-01-04A6-2 | R1 | 4.6 | 0.75 | 4.4 | 0.75 | 3.7 | 0.55 | 6.3 |
| ACS880-01-06A6-2 | R1 | 6.6 | 1.1 | 6.3 | 1.1 | 4.6 | 0.75 | 7.8 |
| ACS880-01-07A5-2 | R1 | 7.5 | 1.5 | 7.1 | 1.5 | 6.6 | 1.1 | 11.2 |
| ACS880-01-10A6-2 | R1 | 10.6 | 2.2 | 10.1 | 2.2 | 7.5 | 1.5 | 12.8 |
| ACS880-01-16A8-2 | R2 | 16.8 | 4.0 | 16 | 4.0 | 10.6 | 2.2 | 18.0 |
| ACS880-01-24A3-2 | R2 | 24.3 | 5.5 | 23.1 | 5.5 | 16.8 | 4 | 28.6 |
| ACS880-01-031A-2 | R3 | 31 | 7.5 | 29.3 | 7.5 | 24.3 | 5.5 | 41 |
| ACS880-01-046A-2 | R4 | 46 | 11 | 44 | 11 | 38 | 7.5 | 64 |
| ACS880-01-061A-2 | R4 | 61 | 15 | 58 | 15 | 45 | 11 | 76 |
| ACS880-01-075A-2 | R5 | 75 | 18.5 | 71 | 18.5 | 61 | 15 | 104 |
| ACS880-01-087A-2 | R5 | 87 | 22 | 83 | 22 | 72 | 18.5 | 122 |
| ACS880-01-115A-2 | R6 | 115 | 30 | 109 | 30 | 87 | 22 | 148 |
| ACS880-01-145A-2 | R6 | 145 | 37 | 138 | 37 | 105 | 30 | 178 |
| ACS880-01-170A-2 | R7 | 170 | 45 | 162 | 45 | 145 | 37 | 247 |
| ACS880-01-206A-2 | R7 | 206 | 55 | 196 | 55 | 169 | 45 | 287 |
| ACS880-01-274A-2 | R8 ³⁾ | 274 | 75 | 260 | 75 | 213 | 55 | 362 |

ACS880-01 **$U_N = 400$ V (range 380 to 415 V). The power ratings are valid at nominal voltage 400 V (0.55 to 250 kW).**

| Drive type | Frame size | Nominal ratings | | Light-duty use | | Heavy-duty use | | Max. output current I_{MAX} (A) |
|------------------|------------------|-----------------|------------|----------------|---------------|-------------------|---------------|--------------------------------------|
| | | I_N (A) | P_n (kW) | I_{Ld} (A) | P_{Ld} (kW) | I_{Hd} (A) | P_{Hd} (kW) | |
| ACS880-01-02A4-3 | R1 | 2.4 | 0.75 | 2.3 | 0.75 | 1.8 | 0.55 | 3.1 |
| ACS880-01-03A3-3 | R1 | 3.3 | 1.1 | 3.1 | 1.1 | 2.4 | 0.75 | 4.1 |
| ACS880-01-04A0-3 | R1 | 4.0 | 1.5 | 3.8 | 1.5 | 3.3 | 1.1 | 5.6 |
| ACS880-01-05A6-3 | R1 | 5.6 | 2.2 | 5.3 | 2.2 | 4 | 1.5 | 6.8 |
| ACS880-01-07A2-3 | R1 | 8.0 | 3 | 7.6 | 3 | 5.6 | 2.2 | 9.5 |
| ACS880-01-09A4-3 | R1 | 10.0 | 4 | 9.5 | 4 | 8 | 3 | 12.2 |
| ACS880-01-12A6-3 | R1 | 12.9 | 5.5 | 12 | 5.5 | 10 | 4 | 16 |
| ACS880-01-017A-3 | R2 | 17 | 7.5 | 16 | 7.5 | 12.6 | 5.5 | 21 |
| ACS880-01-025A-3 | R2 | 25 | 11 | 24 | 11 | 17 | 7.5 | 29 |
| ACS880-01-032A-3 | R3 | 32 | 15 | 30 | 15 | 25 | 11 | 42 |
| ACS880-01-038A-3 | R3 | 38 | 18.5 | 36 | 18.5 | 32 | 15 | 54 |
| ACS880-01-045A-3 | R4 | 45 | 22 | 43 | 22 | 38 | 19 | 64 |
| ACS880-01-061A-3 | R4 | 61 | 30 | 58 | 30 | 45 | 22 | 76 |
| ACS880-01-072A-3 | R5 | 72 | 37 | 68 | 37 | 61 | 30 | 104 |
| ACS880-01-087A-3 | R5 | 87 | 45 | 83 | 45 | 72 | 37 | 122 |
| ACS880-01-105A-3 | R6 | 105 | 55 | 100 | 55 | 87 | 45 | 148 |
| ACS880-01-145A-3 | R6 | 145 | 75 | 138 | 75 | 105 | 55 | 178 |
| ACS880-01-169A-3 | R7 | 169 | 90 | 161 | 90 | 145 | 75 | 247 |
| ACS880-01-206A-3 | R7 | 206 | 110 | 196 | 110 | 269 | 90 | 287 |
| ACS880-01-246A-3 | R8 | 246 | 132 | 234 | 132 | 206 | 110 | 350 |
| ACS880-01-293A-3 | R8 ³⁾ | 293 | 160 | 278 | 160 | 246 ¹⁾ | 132 | 418 |
| ACS880-01-363A-3 | R9 ⁶⁾ | 363 | 200 | 345 | 200 | 293 | 160 | 498 |
| ACS880-01-430A-3 | R9 ⁵⁾ | 430 | 250 | 400 | 200 | 363 ²⁾ | 200 | 545 |

Ratings, types and voltages

ACS880-01, wall-mounted

ACS880-01

$U_N = 400 - 500 \text{ V}$ (range 380 to 500 V). The power ratings are valid at nominal voltage 500 V (0.55 to 250 kW).

| Drive type | Frame size | Nominal ratings | | | $U_N = 400 \text{ V}$ | | | | $U_N = 500 \text{ V}$ | | | | Max. output current $I_{MAX} \text{ (A)}$ |
|------------------|------------------|-----------------------|--------------------|-----------------------|-----------------------|-----------------------|----------------------|-----------------------|-----------------------|-----------------------|----------------------|-----------------------|--|
| | | $U_N = 400 \text{ V}$ | | $U_N = 500 \text{ V}$ | Light-duty use | | Heavy-duty use | | Light-duty use | | Heavy-duty use | | |
| | | $I_N \text{ (A)}$ | $P_n \text{ (kW)}$ | $P_n \text{ (kW)}$ | $I_{Ld} \text{ (A)}$ | $P_{Ld} \text{ (kW)}$ | $I_{Hd} \text{ (A)}$ | $P_{Hd} \text{ (kW)}$ | $I_{Ld} \text{ (A)}$ | $P_{Ld} \text{ (kW)}$ | $I_{Hd} \text{ (A)}$ | $P_{Hd} \text{ (kW)}$ | |
| ACS880-01-02A1-5 | R1 | 2.1 | 0.75 | 0.75 | 2 | 0.55 | 1.7 | 0.55 | 2.0 | 0.75 | 1.7 | 0.55 | 3.1 |
| ACS880-01-03A0-5 | R1 | 3.0 | 1.1 | 1.1 | 2.8 | 1.1 | 2.1 | 0.75 | 2.8 | 1.1 | 2.1 | 0.75 | 4.1 |
| ACS880-01-03A4-5 | R1 | 3.4 | 1.1 | 1.5 | 3.2 | 1.1 | 3 | 1.1 | 3.2 | 1.5 | 3.0 | 1.1 | 5.6 |
| ACS880-01-04A8-5 | R1 | 4.8 | 1.5 | 2.2 | 4.6 | 1.5 | 3.4 | 1.1 | 4.6 | 2.2 | 3.4 | 1.5 | 6.8 |
| ACS880-01-05A2-5 | R1 | 5.2 | 2.2 | 3 | 5 | 2.2 | 4.8 | 1.5 | 5.0 | 3 | 4.8 | 2.2 | 9.5 |
| ACS880-01-07A6-5 | R1 | 7.6 | 3 | 4 | 7.2 | 3 | 5.2 | 2.2 | 7.2 | 4 | 5.2 | 3 | 12.2 |
| ACS880-01-11A0-5 | R1 | 11.0 | 4 | 5.5 | 10.4 | 4 | 7.6 | 3 | 10.4 | 5.5 | 7.6 | 4 | 16 |
| ACS880-01-014A-5 | R2 | 14 | 5.5 | 7.5 | 13 | 5.5 | 11 | 4 | 13 | 7.5 | 11 | 5.5 | 21 |
| ACS880-01-021A-5 | R2 | 21 | 7.5 | 11 | 19 | 7.5 | 14 | 5.5 | 19 | 11 | 14 | 7.5 | 29 |
| ACS880-01-027A-5 | R3 | 27 | 11 | 15 | 26 | 11 | 21 | 7.5 | 26 | 15 | 21 | 11 | 42 |
| ACS880-01-034A-5 | R3 | 34 | 15 | 18.5 | 32 | 15 | 27 | 11 | 32 | 18.5 | 27 | 15 | 54 |
| ACS880-01-040A-5 | R4 | 40 | 18.5 | 22 | 38 | 18.5 | 34 | 15 | 38 | 22 | 34 | 19 | 65 |
| ACS880-01-052A-5 | R4 | 52 | 22 | 30 | 49 | 22 | 40 | 18.5 | 49 | 30 | 40 | 22 | 76 |
| ACS880-01-065A-5 | R5 | 65 | 30 | 37 | 62 | 30 | 52 | 22 | 62 | 37 | 52 | 30 | 104 |
| ACS880-01-077A-5 | R5 | 77 | 37 | 45 | 73 | 37 | 65 | 30 | 73 | 45 | 65 | 37 | 122 |
| ACS880-01-096A-5 | R6 | 96 | 45 | 55 | 91 | 45 | 77 | 37 | 91 | 55 | 77 | 45 | 148 |
| ACS880-01-124A-5 | R6 | 124 | 55 | 75 | 118 | 55 | 96 | 45 | 118 | 75 | 96 | 55 | 178 |
| ACS880-01-156A-5 | R7 | 156 | 75 | 90 | 148 | 75 | 124 | 55 | 148 | 90 | 124 | 75 | 247 |
| ACS880-01-180A-5 | R7 | 180 | 90 | 110 | 171 | 90 | 156 | 75 | 171 | 110 | 156 | 90 | 287 |
| ACS880-01-240A-5 | R8 ⁴⁾ | 240 | 110 | 132 | 228 | 110 | 180 | 90 | 228 | 132 | 180 | 110 | 350 |
| ACS880-01-260A-5 | R8 ³⁾ | 260 | 132 | 160 | 247 | 132 | 240 ¹⁾ | 110 | 247 | 160 | 240 ¹⁾ | 132 | 418 |
| ACS880-01-361A-5 | R9 ⁶⁾ | 361 | 200 | 200 | 343 | 160 | 302 | 160 | 343 | 200 | 302 | 200 | 542 |
| ACS880-01-414A-5 | R9 ⁵⁾ | 414 | 200 | 250 | 393 | 200 | 361 ²⁾ | 200 | 393 | 250 | 361 ²⁾ | 200 | 542 |

ACS880-01 **$U_N = 690$ V (range 525 to 690 V). The power ratings are valid at nominal voltage 690 V (4 to 250 kW).**

| Drive type | Frame size | Nominal ratings | | Light-duty use | | Heavy-duty use | | Max. output current I_{MAX} (A) |
|------------------|------------------|-----------------|------------|----------------|---------------|----------------|---------------|--------------------------------------|
| | | I_N (A) | P_n (kW) | I_{Ld} (A) | P_{Ld} (kW) | I_{Hd} (A) | P_{Hd} (kW) | |
| ACS880-01-07A4-7 | R3 | 7.4 | 5.5 | 7.0 | 5.5 | 5.6 | 4 | 12.2 |
| ACS880-01-09A9-7 | R3 | 9.9 | 7.5 | 9.4 | 7.5 | 7.4 | 5.5 | 18 |
| ACS880-01-14A3-7 | R3 | 14.3 | 11 | 13.6 | 11 | 9.9 | 7.5 | 22 |
| ACS880-01-019A-7 | R3 | 19 | 15 | 18 | 15 | 14.3 | 11 | 29 |
| ACS880-01-023A-7 | R3 | 23 | 18.5 | 22 | 18.5 | 19 | 15 | 38 |
| ACS880-01-027A-7 | R3 | 27 | 22 | 26 | 22 | 23 | 18.5 | 46 |
| ACS880-01-07A3-7 | R5 | 7.3 | 5.5 | 6.9 | 5.5 | 5.6 | 4 | 12.2 |
| ACS880-01-09A8-7 | R5 | 9.8 | 7.5 | 9.3 | 7.5 | 7.3 | 5.5 | 18 |
| ACS880-01-14A2-7 | R5 | 14.2 | 11 | 13.5 | 11 | 9.8 | 7.5 | 22 |
| ACS880-01-018A-7 | R5 | 18 | 15 | 17 | 15 | 14.2 | 11 | 29 |
| ACS880-01-022A-7 | R5 | 22 | 18.5 | 21 | 18.5 | 18 | 15 | 44 |
| ACS880-01-026A-7 | R5 | 26 | 22 | 25 | 22 | 22 | 18.5 | 54 |
| ACS880-01-035A-7 | R5 | 35 | 30 | 33 | 30 | 26 | 22 | 64 |
| ACS880-01-042A-7 | R5 | 42 | 37 | 40 | 37 | 35 | 30 | 74 |
| ACS880-01-049A-7 | R5 | 49 | 45 | 47 | 45 | 42 | 37 | 76 |
| ACS880-01-061A-7 | R6 | 61 | 55 | 58 | 55 | 49 | 45 | 104 |
| ACS880-01-084A-7 | R6 | 84 | 75 | 80 | 75 | 61 | 55 | 124 |
| ACS880-01-098A-7 | R7 | 98 | 90 | 93 | 90 | 84 | 75 | 168 |
| ACS880-01-119A-7 | R7 | 119 | 110 | 113 | 110 | 98 | 90 | 198 |
| ACS880-01-142A-7 | R8 | 142 | 132 | 135 | 132 | 119 | 110 | 250 |
| ACS880-01-174A-7 | R8 ³⁾ | 174 | 160 | 165 | 160 | 142 | 132 | 274 |
| ACS880-01-210A-7 | R9 ⁷⁾ | 210 | 200 | 200 | 200 | 174 | 160 | 384 |
| ACS880-01-271A-7 | R9 ⁵⁾ | 271 | 250 | 257 | 250 | 210 | 200 | 411 |

¹⁾ 130 % overload²⁾ 125 % overload³⁾ For drives with enclosure class IP55 the ratings apply at 40 °C ambient temperature.

At higher temperature the derating is from 40 to 45 °C 1%/1 °C and 45 to 55 °C 2.5%/1 °C.

⁴⁾ For drives with enclosure class IP55 the ratings apply at 40 °C ambient temperature.

At higher temperature the derating is from 40 to 50 °C 1%/1 °C and 50 to 55 °C 2.5%/1 °C.

⁵⁾ For drives with enclosure class IP55 the maximum ambient temperature is 35 °C.⁶⁾ For drives with enclosure class IP55 the ratings apply at 40 °C ambient temperature.

At higher temperatures the derating is from 40 to 45 °C 1%/1 °C and 45 to 50 °C 2.5%/1 °C and 50 to 55 °C 5%/1 °C.

⁷⁾ For drives with IP55 enclosure class the ratings apply at 40 °C ambient temperature.

At higher temperatures the derating is from 40 to 45 °C 3.5%/1 °C. Note: Maximum ambient temperature is 45 °C.

Nominal ratings

| | |
|-----------|--|
| I_N | Rated current available continuously without overloading at 40 °C (104 °F). |
| I_{max} | Maximum output current. Available for 10 s at start, otherwise as long as allowed by drive temperature. Note: maximum motor shaft power is 150 % P_{Hd} . |

Typical ratings: No-overload use

| | |
|-------|---|
| P_N | Typical motor power in no-overload use. |
|-------|---|

Light-duty use

| | |
|----------|--|
| I_{Ld} | Continuous current allowing 110% I_{Ld} for 1 min/5 min at 40 °C (104 °F). |
| P_{Ld} | Typical motor power in light-duty use. |

Heavy-duty use

| | |
|----------|--|
| I_{Hd} | Continuous current allowing 150 % I_{Ld} for 1 minute every 10 minutes at 40 °C. |
| P_{Hd} | Typical motor power in heavy-duty use. |

Ratings, types and voltages

ACS880-04, ACS880-04XT, ACS880-04F,
ACS880-04FXT, drive modules



ACS880-04 $U_N = 400$ V (range 380 to 415 V). The power ratings are valid at nominal voltage 400 V (200 to 500 kW).**6-pulse**

| Drive type | Frame size | Nominal ratings | | Light-duty use | | Heavy-duty use | | Max. output current I_{MAX} (A) |
|------------------|------------|-----------------|------------|----------------|---------------|--------------------|---------------|--------------------------------------|
| | | I_N (A) | P_n (kW) | I_{Ld} (A) | P_{Ld} (kW) | I_{Hd} (A) | P_{Hd} (kW) | |
| ACS880-04-505A-3 | R10 | 505 | 250 | 485 | 250 | 361 | 200 | 560 |
| ACS880-04-585A-3 | R10 | 585 | 315 | 575 | 315 | 429 | 250 | 730 |
| ACS880-04-650A-3 | R10 | 650 | 355 | 634 | 355 | 477 | 250 | 730 |
| ACS880-04-725A-3 | R11 | 725 | 400 | 715 | 400 | 566 | 315 | 1020 |
| ACS880-04-820A-3 | R11 | 820 | 450 | 810 | 450 | 625 | 355 | 1020 |
| ACS880-04-880A-3 | R11 | 880 | 500 | 865 | 500 | 725 [*]) | 400 | 1100 |

ACS880-04 $U_N = 500$ V (range 380 to 500 V). The power ratings are valid at nominal voltage 500 V (200 to 630 kW).**6-pulse**

| Drive type | Frame size | Nominal ratings | | Light-duty use | | Heavy-duty use | | Max. output current I_{MAX} (A) |
|------------------|------------|-----------------|------------|----------------|---------------|---------------------|---------------|--------------------------------------|
| | | I_N (A) | P_n (kW) | I_{Ld} (A) | P_{Ld} (kW) | I_{Hd} (A) | P_{Hd} (kW) | |
| ACS880-04-460A-5 | R10 | 460 | 315 | 450 | 315 | 330 | 200 | 560 |
| ACS880-04-503A-5 | R10 | 503 | 355 | 483 | 315 | 361 | 250 | 560 |
| ACS880-04-583A-5 | R10 | 583 | 400 | 573 | 400 | 414 | 250 | 730 |
| ACS880-04-635A-5 | R10 | 635 | 450 | 623 | 450 | 477 | 315 | 730 |
| ACS880-04-715A-5 | R11 | 715 | 500 | 705 | 500 | 566 | 400 | 850 |
| ACS880-04-820A-5 | R11 | 820 | 560 | 807 | 560 | 625 | 450 | 1020 |
| ACS880-04-880A-5 | R11 | 880 | 630 | 857 | 560 | 697 ^{***)} | 500 | 1100 |

ACS880-04 $U_N = 690$ V (range 525 to 690 V). The power ratings are valid at nominal voltage 690 V (250 to 710 kW).**6-pulse**

| Drive type | Frame size | Nominal ratings | | Light-duty use | | Heavy-duty use | | Max. output current I_{MAX} (A) |
|------------------|------------|-----------------|------------|----------------|---------------|---------------------|---------------|--------------------------------------|
| | | I_N (A) | P_n (kW) | I_{Ld} (A) | P_{Ld} (kW) | I_{Hd} (A) | P_{Hd} (kW) | |
| ACS880-04-330A-7 | R10 | 330 | 315 | 320 | 315 | 255 | 250 | 480 |
| ACS880-04-370A-7 | R10 | 370 | 355 | 360 | 355 | 325 | 315 | 520 |
| ACS880-04-430A-7 | R10 | 430 | 400 | 420 | 400 | 360 [*]) | 355 | 540 |
| ACS880-04-470A-7 | R11 | 470 | 450 | 455 | 450 | 415 | 400 | 655 |
| ACS880-04-522A-7 | R11 | 522 | 500 | 505 | 500 | 455 | 450 | 685 |
| ACS880-04-590A-7 | R11 | 590 | 560 | 570 | 560 | 505 | 500 | 800 |
| ACS880-04-650A-7 | R11 | 650 | 630 | 630 | 630 | 571 ^{***)} | 560 | 825 |
| ACS880-04-721A-7 | R11 | 721 | 710 | 705 | 630 | 571 ^{***)} | 560 | 825 |

The ratings apply at 40 °C ambient temperature. At higher temperatures (up to 50 °C⁵⁾ or up to 55 °C⁶⁾) the derating is 1%/1 °C.

Ratings, types and voltages

ACS880-04, ACS880-04XT, ACS880-04F, ACS880-04FXT, drive modules

ACS880-04F

$U_N = 400\text{ V}$ (range 380 to 415 V). The power ratings are valid at nominal voltage 400 V (200 to 500 kW).

| Drive type | Frame size | Nominal ratings | | Light-duty use | | Heavy-duty use | | Max. output current I_{MAX} (A) |
|-------------------|------------|-----------------|------------|----------------|---------------|------------------|---------------|--------------------------------------|
| | | I_N (A) | P_n (kW) | I_{Ld} (A) | P_{Ld} (kW) | I_{Hd} (A) | P_{Hd} (kW) | |
| ACS880-04F-504A-3 | R11 | 504 | 250 | 485 | 250 | 361 | 200 | 560 |
| ACS880-04F-584A-3 | R11 | 584 | 315 | 575 | 315 | 429 | 250 | 730 |
| ACS880-04F-649A-3 | R11 | 649 | 355 | 634 | 355 | 477 | 250 | 730 |
| ACS880-04F-725A-3 | R11 | 725 | 400 | 715 | 400 | 566 | 315 | 1020 |
| ACS880-04F-820A-3 | R11 | 820 | 450 | 810 | 450 | 625 | 355 | 1020 |
| ACS880-04F-880A-3 | R11 | 880 | 500 | 865 | 500 | 725 [*] | 400 | 1100 |

ACS880-04F

$U_N = 500\text{ V}$ (range 380 to 500 V). The power ratings are valid at nominal voltage 500 V (200 to 630 kW).

| Drive type | Frame size | Nominal ratings | | Light-duty use | | Heavy-duty use | | Max. output current I_{MAX} (A) |
|-------------------|------------|-----------------|------------|----------------|---------------|-------------------|---------------|--------------------------------------|
| | | I_N (A) | P_n (kW) | I_{Ld} (A) | P_{Ld} (kW) | I_{Hd} (A) | P_{Hd} (kW) | |
| ACS880-04F-459A-5 | R11 | 459 | 315 | 450 | 315 | 330 | 200 | 560 |
| ACS880-04F-502A-5 | R11 | 502 | 355 | 483 | 315 | 361 | 250 | 560 |
| ACS880-04F-582A-5 | R11 | 582 | 400 | 573 | 400 | 414 | 250 | 730 |
| ACS880-04F-634A-5 | R11 | 634 | 450 | 623 | 450 | 477 | 315 | 730 |
| ACS880-04F-715A-5 | R11 | 715 | 500 | 705 | 500 | 566 | 400 | 850 |
| ACS880-04F-820A-5 | R11 | 820 | 560 | 807 | 560 | 625 | 450 | 1020 |
| ACS880-04F-880A-5 | R11 | 880 | 630 | 857 | 560 | 697 ^{**} | 500 | 1100 |

ACS880-04F

$U_N = 690\text{ V}$ (range 525 to 690 V). The power ratings are valid at nominal voltage 690 V (250 to 710 kW).

| Drive type | Frame size | Nominal ratings | | Light-duty use | | Heavy-duty use | | Max. output current I_{MAX} (A) |
|-------------------|------------|-----------------|------------|----------------|---------------|-------------------|---------------|--------------------------------------|
| | | I_N (A) | P_n (kW) | I_{Ld} (A) | P_{Ld} (kW) | I_{Hd} (A) | P_{Hd} (kW) | |
| ACS880-04F-329A-7 | R11 | 329 | 315 | 320 | 315 | 255 | 250 | 480 |
| ACS880-04F-369A-7 | R11 | 369 | 355 | 360 | 355 | 325 | 315 | 520 |
| ACS880-04F-429A-7 | R11 | 429 | 400 | 420 | 400 | 360 ^{**} | 355 | 520 |
| ACS880-04F-470A-7 | R11 | 470 | 450 | 455 | 450 | 415 | 400 | 655 |
| ACS880-04F-522A-7 | R11 | 522 | 500 | 505 | 500 | 455 | 450 | 655 |
| ACS880-04F-590A-7 | R11 | 590 | 560 | 571 | 560 | 505 | 500 | 800 |
| ACS880-04F-650A-7 | R11 | 650 | 630 | 630 | 630 | 571 ^{**} | 560 | 820 |
| ACS880-04F-721A-7 | R11 | 721 | 710 | 705 | 630 | 571 ^{**} | 560 | 820 |

ACS880-04F**NEMA ratings, $U_N = 460$ V**

| Drive type | Frame size | Input current I_1 (A) | Output ratings | | | | Maximum current | |
|-------------------|------------|----------------------------|----------------|--------------------------------|----------------|--------------------------------|-----------------|---------------------|
| | | | Light-duty use | | Heavy-duty use | | I_{Max} (A) | I_{Max} Start (A) |
| | | | I_{Ld} (A) | P_{Ld} (kW) $U_N = 460$ V | I_{Hd} (A) | P_{Hd} (kW) $U_N = 400$ V | | |
| ACS880-04F-502A-5 | R11 | 502 | 483 | 315 | 361 | 250 | 560 | 671 |
| ACS880-04F-582A-5 | R11 | 582 | 573 | 400 | 414 | 250 | 730 | 828 |
| ACS880-04F-634A-5 | R11 | 634 | 623 | 450 | 477 | 315 | 730 | 954 |
| ACS880-04F-715A-5 | R11 | 715 | 705 | 500 | 566 | 400 | 850 | 1100 |
| ACS880-04F-820A-5 | R11 | 820 | 807 | 560 | 625 | 450 | 1020 | 1100 |
| ACS880-04F-880A-5 | R11 | 880 | 857 | 560 | 697**) | 500 | 1100 | 1100 |

ACS880-04XT **$U_N = 400$ V (range 380 to 415 V). The power ratings are valid at nominal voltage 400 V (400 to 900 kW).****6- or 12-pulse**

| Drive type | Frame size | Nominal ratings | | Light-duty use | | Heavy-duty use | | Max. output current I_{MAX} (A) |
|---------------------|------------|-----------------|------------|----------------|---------------|----------------|---------------|--------------------------------------|
| | | I_N (A) | P_n (kW) | I_{Ld} (A) | P_{Ld} (kW) | I_{Hd} (A) | P_{Hd} (kW) | |
| ACS880-04XT-1010A-3 | 2×R10 | 1010 | 560 | 997 | 560 | 746 | 400 | 1270 |
| ACS880-04XT-1190A-3 | 2×R10 | 1190 | 630 | 1167 | 630 | 878 | 500 | 1343 |
| ACS880-04XT-1330A-3 | 2×R11 | 1330 | 710 | 1316 | 710 | 1041 | 560 | 1886 |
| ACS880-04XT-1610A-3 | 2×R11 | 1610 | 900 | 1570 | 900 | 1334*) | 710 | 2024 |

ACS880-04XT **$U_N = 500$ V (range 380 to 500 V). The power ratings are valid at nominal voltage 500 V (500 to 1000 kW).****6- or 12-pulse**

| Drive type | Frame size | Nominal ratings | | Light-duty use | | Heavy-duty use | | Max. output current I_{MAX} (A) |
|---------------------|------------|-----------------|------------|----------------|---------------|----------------|---------------|--------------------------------------|
| | | I_N (A) | P_n (kW) | I_{Ld} (A) | P_{Ld} (kW) | I_{Hd} (A) | P_{Hd} (kW) | |
| ACS880-04XT-1010A-5 | 2×R10 | 1010 | 710 | 997 | 710 | 720 | 500 | 1270 |
| ACS880-04XT-1160A-5 | 2×R10 | 1160 | 800 | 1146 | 800 | 878 | 630 | 1343 |
| ACS880-04XT-1310A-5 | 2×R11 | 1310 | 900 | 1297 | 900 | 1041 | 710 | 1564 |
| ACS880-04XT-1610A-5 | 2×R11 | 1610 | 1000 | 1570 | 1000 | 1282**) | 900 | 2024 |

ACS880-04XT **$U_N = 690$ V (range 525 to 690 V). The power ratings are valid at nominal voltage 690 V (630 to 1200 kW).****6- or 12-pulse**

| Drive type | Frame size | Nominal ratings | | Light-duty use | | Heavy-duty use | | Max. output current I_{MAX} (A) |
|---------------------|------------|-----------------|------------|----------------|---------------|----------------|---------------|--------------------------------------|
| | | I_N (A) | P_n (kW) | I_{Ld} (A) | P_{Ld} (kW) | I_{Hd} (A) | P_{Hd} (kW) | |
| ACS880-04XT-0810A-7 | 2×R10 | 810 | 800 | 791 | 710 | 678***) | 630 | 1017 |
| ACS880-04XT-0960A-7 | 2×R11 | 960 | 900 | 929 | 900 | 837 | 800 | 1260 |
| ACS880-04XT-1080A-7 | 2×R11 | 1080 | 1000 | 1051 | 1000 | 929 | 900 | 1472 |
| ACS880-04XT-1320A-7 | 2×R11 | 1320 | 1200 | 1297 | 1200 | 1051***) | 1000 | 1509 |

The ratings apply at 40 °C ambient temperature. At higher temperatures (up to 50 °C⁵⁾ or up to 55 °C⁶⁾ the derating is 1%/1 °C.

Ratings, types and voltages

ACS880-04, ACS880-04XT, ACS880-04F, ACS880-04FXT, drive modules

ACS880-04FXT, 6- or 12-pulse

$U_N = 400$ V (range 380 to 415 V). The power ratings are valid at nominal voltage 400 V (200 to 1800 kW).

| Drive type | Frame size | Nominal ratings | | | | Light overload use | | Heavy-duty use | | Noise level (dB(A)) | Heat dissipation (W) | Air flow (m ³ /h) |
|----------------------|------------|-----------------|---------------|----------------------|------------|--------------------|---------------|--------------------|---------------|---------------------|----------------------|------------------------------|
| | | I_N (A) | I_{max} (A) | I_{max_start} (A) | P_N (kW) | I_{Ld} (A) | P_{Ld} (kW) | I_{Hd} (A) | P_{Hd} (kW) | | | |
| ACS880-04FXT-1008A-3 | 2xR11 | 1008 | 1270 | 1441 | 560 | 997 | 560 | 746 | 400 | 78 | 9990 | 3040 |
| ACS880-04FXT-1188A-3 | 2xR11 | 1188 | 1343 | 1755 | 630 | 1167 | 630 | 878 | 500 | 78 | 14098 | 3040 |
| ACS880-04FXT-1330A-3 | 2xR11 | 1330 | 1886 | 2024 | 710 | 1316 | 710 | 1041 | 560 | 78 | 15222 | 3040 |
| ACS880-04FXT-1610A-3 | 2xR11 | 1610 | 2024 | 2024 | 900 | 1570 | 900 | 1334 ¹⁾ | 710 | 78 | 18336 | 3040 |

ACS880-04FXT, 6- or 12-pulse

$U_N = 500$ V (range 380 to 500 V). The power ratings are valid at nominal voltage 500 V (200 to 2000 kW).

| Drive type | Frame size | Nominal ratings | | | | Light overload use | | Heavy-duty use | | Noise level (dB(A)) | Heat dissipation (W) | Air flow (m ³ /h) |
|----------------------|------------|-----------------|---------------|----------------------|------------|--------------------|---------------|--------------------|---------------|---------------------|----------------------|------------------------------|
| | | I_N (A) | I_{max} (A) | I_{max_start} (A) | P_N (kW) | I_{Ld} (A) | P_{Ld} (kW) | I_{Hd} (A) | P_{Hd} (kW) | | | |
| ACS880-04FXT-1008A-5 | 2xR11 | 1008 | 1270 | 1441 | 710 | 997 | 710 | 720 | 500 | 78 | 9990 | 3040 |
| ACS880-04FXT-1158A-5 | 2xR11 | 1158 | 1343 | 1755 | 800 | 1146 | 800 | 878 | 630 | 78 | 14098 | 3040 |
| ACS880-04FXT-1310A-5 | 2xR11 | 1310 | 1564 | 2024 | 900 | 1297 | 900 | 1041 | 710 | 78 | 15222 | 3040 |
| ACS880-04FXT-1610A-5 | 2xR11 | 1610 | 2024 | 2024 | 1000 | 1570 | 1000 | 1282 ²⁾ | 900 | 78 | 19201 | 3040 |

ACS880-04FXT, 6- or 12-pulse

$U_N = 690$ V (range 525 to 690 V). The power ratings are valid at nominal voltage 690 V (250 to 2400 kW).

| Drive type | Frame size | Nominal ratings | | | | Light overload use | | Heavy-duty use | | Noise level (dB(A)) | Heat dissipation (W) | Air flow (m ³ /h) |
|----------------------|------------|-----------------|---------------|----------------------|------------|--------------------|---------------|--------------------|---------------|---------------------|----------------------|------------------------------|
| | | I_N (A) | I_{max} (A) | I_{max_start} (A) | P_N (kW) | I_{Ld} (A) | P_{Ld} (kW) | I_{Hd} (A) | P_{Hd} (kW) | | | |
| ACS880-04FXT-0808A-7 | 2xR11 | 808 | 1017 | 1356 | 800 | 791 | 710 | 678 ³⁾ | 630 | 78 | 11691 | 3040 |
| ACS880-04FXT-0960A-7 | 2xR11 | 960 | 1260 | 1674 | 900 | 929 | 900 | 837 | 800 | 78 | 15222 | 3040 |
| ACS880-04FXT-1080A-7 | 2xR11 | 1080 | 1472 | 1858 | 1000 | 1051 | 1000 | 929 | 900 | 78 | 17125 | 3040 |
| ACS880-04FXT-1320A-7 | 2xR11 | 1320 | 1509 | 2024 | 1200 | 1297 | 1200 | 1051 ³⁾ | 1000 | 78 | 19201 | 3040 |

ACS880-04, ACS880-04XT, ACS880-04F, ACS880-04FXT**Nominal ratings**

| | |
|----------------------|--|
| I_N | Rated current available continuously without overloading at 40 °C (104 °F). |
| I_{max} | Maximum output current. Available for 10 s at start, otherwise as long as allowed by drive temperature. Note: maximum motor shaft power is 150 % P_{Hd} . |
| I_{max_Start} (A) | Maximum output current at start. Available for two seconds only at start every seven seconds if start current limit is activated by parameter 30.15 maximum start current. |

Typical ratings: No-overload use

| | |
|-------|---|
| P_N | Typical motor power in no-overload use. |
|-------|---|

Light-duty use

| | |
|----------|---|
| I_{Ld} | Continuous current allowing 110 % I_{Ld} for 1 min/5 min at 40 °C (104 °F). |
| P_{Ld} | Typical motor power in light-duty use. |

Heavy-duty use

| | |
|----------|--|
| I_{Hd} | Continuous current allowing 150 % I_{Hd} for 1 minute every 10 minutes at 40 °C. *) Continuous rms output current allowing 40 % overload for 1 minute every 5 minutes. **) Continuous rms output current allowing 45 % overload for 1 minute every 5 minutes. ***) Continuous rms output current allowing 44 % overload for 1 minute every 5 minutes. |
| P_{Hd} | Typical motor power in heavy-duty use. |

Input current

| | |
|-----------|--|
| I_1 (A) | Nominal input current (rms) at 40 °C (104 °F). |
|-----------|--|

Ratings, types and voltages

ACS880-07, cabinet-built



ACS880-07 **$U_N = 400$ V (range 380 to 415 V). The power ratings are valid at nominal voltage 400 V (45 to 500 kW).**

| Drive type | Frame size | Nominal ratings | | Light-duty use | | Heavy-duty use | | Max. output current I_{MAX} (A) |
|-------------------|------------|-----------------|------------|----------------|---------------|-------------------|---------------|--------------------------------------|
| | | I_N (A) | P_n (kW) | I_{Ld} (A) | P_{Ld} (kW) | I_{Hd} (A) | P_{Hd} (kW) | |
| ACS880-07-0105A-3 | R6 | 105 | 55 | 100 | 55 | 87 | 45 | 148 |
| ACS880-07-0145A-3 | R6 | 145 | 75 | 138 | 75 | 105 | 55 | 178 |
| ACS880-07-0169A-3 | R7 | 169 | 90 | 161 | 90 | 145 | 75 | 247 |
| ACS880-07-0206A-3 | R7 | 206 | 110 | 196 | 110 | 169 | 90 | 287 |
| ACS880-07-0246A-3 | R8 | 246 | 132 | 234 | 132 | 206 | 110 | 350 |
| ACS880-07-0293A-3 | R8 | 293 | 160 | 278 | 160 | 246 ¹⁾ | 132 | 418 |
| ACS880-07-0363A-3 | R9 | 363 | 200 | 345 | 200 | 293 | 160 | 498 |
| ACS880-07-0430A-3 | R9 | 430 | 250 | 400 | 200 | 363 ²⁾ | 200 | 545 |
| ACS880-07-0505A-3 | R10 | 505 | 250 | 485 | 250 | 361 | 200 | 560 |
| ACS880-07-0585A-3 | R10 | 585 | 315 | 575 | 315 | 429 | 250 | 730 |
| ACS880-07-0650A-3 | R10 | 650 | 355 | 634 | 355 | 477 | 250 | 730 |
| ACS880-07-0725A-3 | R11 | 725 | 400 | 715 | 400 | 566 | 315 | 1020 |
| ACS880-07-0820A-3 | R11 | 820 | 450 | 810 | 450 | 625 | 355 | 1020 |
| ACS880-07-0880A-3 | R11 | 880 | 500 | 865 | 500 | 725 ³⁾ | 400 | 1100 |

ACS880-07 **$U_N = 500$ V (range 380 to 500 V). The power ratings are valid at nominal voltage 500 V (45 to 560 kW).**

| Drive type | Frame size | Nominal ratings | | Light-duty use | | Heavy-duty use | | Max. output current I_{MAX} (A) |
|-------------------|------------|-----------------|------------|----------------|---------------|--------------------|---------------|--------------------------------------|
| | | I_N (A) | P_n (kW) | I_{Ld} (A) | P_{Ld} (kW) | I_{Hd} (A) | P_{Hd} (kW) | |
| ACS880-07-0096A-5 | R6 | 96 | 55 | 91 | 55 | 77 | 45 | 148 |
| ACS880-07-0124A-5 | R6 | 124 | 75 | 118 | 75 | 96 | 55 | 178 |
| ACS880-07-0156A-5 | R7 | 156 | 90 | 148 | 90 | 124 | 75 | 247 |
| ACS880-07-0180A-5 | R7 | 180 | 110 | 171 | 110 | 156 | 90 | 287 |
| ACS880-07-0240A-5 | R8 | 240 | 132 | 228 | 132 | 180 | 110 | 350 |
| ACS880-07-0260A-5 | R8 | 260 | 160 | 247 | 160 | 240 [*] | 132 | 418 |
| ACS880-07-0361A-5 | R9 | 361 | 200 | 343 | 200 | 302 | 200 | 542 |
| ACS880-07-0414A-5 | R9 | 414 | 250 | 393 | 250 | 361 ^{**)} | 200 | 542 |
| ACS880-07-0460A-5 | R10 | 460 | 315 | 450 | 315 | 330 | 200 | 560 |
| ACS880-07-0503A-5 | R10 | 503 | 355 | 483 | 315 | 361 | 250 | 560 |
| ACS880-07-0583A-5 | R10 | 583 | 400 | 573 | 400 | 414 | 250 | 730 |
| ACS880-07-0635A-5 | R10 | 635 | 450 | 623 | 450 | 477 | 315 | 730 |
| ACS880-07-0715A-5 | R11 | 715 | 500 | 705 | 500 | 566 | 400 | 850 |
| ACS880-07-0820A-5 | R11 | 820 | 560 | 807 | 560 | 625 | 450 | 1020 |

Ratings, types and voltages

ACS880-07, cabinet-built

ACS880-07

$U_N = 690$ V (range 525 to 690 V). The power ratings are valid at nominal voltage 690 V (45 to 630 kW).

| Drive type | Frame size | Nominal ratings | | Light-duty use | | Heavy-duty use | | Max. output current I_{MAX} (A) |
|-------------------|------------|-----------------|------------|----------------|---------------|----------------|---------------|--------------------------------------|
| | | I_N (A) | P_n (kW) | I_{Ld} (A) | P_{Ld} (kW) | I_{Hd} (A) | P_{Hd} (kW) | |
| ACS880-07-0061A-7 | R6 | 61 | 55 | 58 | 55 | 49 | 45 | 104 |
| ACS880-07-0084A-7 | R6 | 84 | 75 | 80 | 75 | 61 | 55 | 124 |
| ACS880-07-0098A-7 | R7 | 98 | 90 | 93 | 90 | 84 | 75 | 168 |
| ACS880-07-0119A-7 | R7 | 119 | 110 | 113 | 110 | 98 | 90 | 198 |
| ACS880-07-0142A-7 | R8 | 142 | 132 | 135 | 132 | 119 | 110 | 250 |
| ACS880-07-0174A-7 | R8 | 174 | 160 | 165 | 160 | 142 | 132 | 274 |
| ACS880-07-0210A-7 | R9 | 210 | 200 | 200 | 200 | 174 | 160 | 384 |
| ACS880-07-0271A-7 | R9 | 271 | 250 | 257 | 250 | 210 | 200 | 411 |
| ACS880-07-0330A-7 | R10 | 330 | 315 | 320 | 315 | 255 | 250 | 480 |
| ACS880-07-0370A-7 | R10 | 370 | 355 | 360 | 355 | 325 | 315 | 520 |
| ACS880-07-0425A-7 | R11 | 425 | 400 | 415 | 400 | 360 | 355 | 520 |
| ACS880-07-0470A-7 | R11 | 470 | 450 | 455 | 450 | 415 | 400 | 655 |
| ACS880-07-0522A-7 | R11 | 522 | 500 | 505 | 500 | 455 | 450 | 655 |
| ACS880-07-0590A-7 | R11 | 590 | 560 | 571 | 560 | 505 | 500 | 800 |
| ACS880-07-0650A-7 | R11 | 650 | 630 | 630 | 630 | 571 | 560 | 820 |

NEMA ratings $U_N = 460$ V

| Drive type | Frame size | Nominal ratings I_N (A) | Apperent Power S_N (kVA) | Light-duty use | | Heavy-duty use | | Max. output current I_{MAX} (A) |
|-------------------|------------|------------------------------|-------------------------------|----------------|--------------------------------|----------------|--------------------------------|--------------------------------------|
| | | | | I_{Ld} (A) | $U_N = 460$ V P_{Ld} (kW) | I_{Hd} (A) | $U_N = 400$ V P_{Hd} (kW) | |
| ACS880-07-0096A-5 | R6 | 96 | 83 | 96 | 55 | 77 | 45 | 148 |
| ACS880-07-0124A-5 | R6 | 124 | 107 | 124 | 75 | 96 | 55 | 178 |
| ACS880-07-0156A-5 | R7 | 156 | 135 | 156 | 90 | 124 | 75 | 247 |
| ACS880-07-0180A-5 | R7 | 180 | 156 | 180 | 110 | 156 | 90 | 287 |
| ACS880-07-0240A-5 | R8 | 240 | 208 | 240 | 132 | 180 | 110 | 350 |
| ACS880-07-0302A-5 | R9 | 302 | 262 | 302 | 200 | 260 | 132 | 498 |
| ACS880-07-0361A-5 | R9 | 361 | 313 | 361 | 200 | 302 | 200 | 542 |
| ACS880-07-0414A-5 | R9 | 414 | 359 | 414 | 250 | 361 **) | 200 | 542 |
| ACS880-07-0503A-5 | R10 | 503 | 436 | 483 | 315 | 361 | 250 | 560 |
| ACS880-07-0583A-5 | R10 | 583 | 505 | 573 | 400 | 414 | 250 | 730 |
| ACS880-07-0635A-5 | R10 | 635 | 550 | 623 | 450 | 477 | 315 | 730 |
| ACS880-07-0715A-5 | R11 | 715 | 619 | 705 | 500 | 566 | 400 | 850 |
| ACS880-07-0820A-5 | R11 | 820 | 710 | 807 | 560 | 625 | 450 | 1020 |
| ACS880-07-0880A-5 | R11 | 880 | 762 | 857 | 560 | 697 ***) | 500 | 1100 |

| NEMA ratings $U_N = 600\text{ V}$ | | | | | | | | |
|-----------------------------------|------------|-----------------|----------------|----------------|---------------------------------------|----------------|---------------------------------------|---------------------|
| Drive type | Frame size | Nominal ratings | Apperent power | Light-duty use | | Heavy-duty use | | Max. output current |
| | | | | I_{Ld} (A) | $U_N = 460\text{ V}$ P_{Ld} (kW) | I_{Hd} (A) | $U_N = 400\text{ V}$ P_{Hd} (kW) | |
| | | I_N (A) | S_N (kVA) | | | | | I_{MAX} (A) |
| ACS880-07-0061A-7 | R6 | 61 | 73 | 62 | 45 | 52 | 37 | 104 |
| ACS880-07-0084A-7 | R6 | 84 | 100 | 77 | 55 | 62 | 45 | 124 |
| ACS880-07-0098A-7 | R7 | 98 | 117 | 99 | 75 | 77 | 55 | 168 |
| ACS880-07-0119A-7 | R7 | 119 | 142 | 125 | 90 | 99 | 75 | 198 |
| ACS880-07-0142A-7 | R8 | 142 | 170 | 144 | 110 | 125 | 90 | 250 |
| ACS880-07-0174A-7 | R8 | 174 | 208 | 180 | 132 | 144 | 110 | 274 |
| ACS880-07-0210A-7 | R9 | 210 | 251 | 242 | 160 | 192 | 132 | 384 |
| ACS880-07-0271A-7 | R9 | 271 | 324 | 271 | 200 | 242 *) | 160 | 411 |
| ACS880-07-0330A-7 | R10 | 330 | 394 | 336 | 315 | 255 | 250 | 480 |
| ACS880-07-0370A-7 | R10 | 370 | 442 | 382 | 355 | 325 | 315 | 520 |
| ACS880-07-0430A-7 | R10 | 430 | 514 | 424 | 400 | 360 ****) | 355 | 520 |
| ACS880-07-0470A-7 | R11 | 470 | 562 | 472 | 450 | 415 | 400 | 655 |
| ACS880-07-0522A-7 | R11 | 522 | 624 | 528 | 500 | 455 | 450 | 655 |
| ACS880-07-0590A-7 | R11 | 590 | 705 | 571 | 560 | 505 | 500 | 800 |
| ACS880-07-0650A-7 | R11 | 650 | 777 | 630 | 630 | 571 ****) | 560 | 820 |
| ACS880-07-0721A-7 | R11 | 721 | 862 | 705 | 630 | 571 ****) | 560 | 820 |

Nominal ratings

| | |
|-----------|--|
| I_N | Nominal output current (available continuously with no over-loading). |
| S_N | Apparent power in no-overload use. |
| I_{max} | Maximum output current. Available for 10 seconds at start, then as long as allowed by drive temperature. |

Typical ratings: No-overload use

| | |
|-------|---|
| P_N | Typical motor power in no-overload use. |
|-------|---|

Light-duty use

| | |
|----------|--|
| I_{Ld} | Continuous rms output current allowing 10 % overload for 1 minute every 5 minutes. |
| P_{Ld} | Typical motor power in light-duty use. |

Heavy-duty use

| | |
|----------|--|
| I_{Hd} | <p>Continuous rms output current allowing 50 % overload for 1 minute every 5 minutes.</p> <p>*) Continuous rms output current allowing 30 % overload for 1 minute every 5 minutes.</p> <p>**) Continuous rms output current allowing 25 % overload for 1 minute every 5 minutes.</p> <p>***) Continuous rms output current allowing 40 % overload for 1 minute every 5 minutes.</p> <p>****) Continuous rms output current allowing 45% overload for 1 minute every 5 minutes.</p> |
| P_{Hd} | Typical motor power in heavy-duty use. |

Note 1: The ratings apply at an ambient temperature of 40 °C (104 °F).

Note 2: To achieve the rated motor power given in the table, the rated current of the drive must be higher than or equal to the rated motor current.

Note 3 – ACS880-07-0174A-7 amp rating: The drive can deliver 192 A continuously with no overload.

Note 4 – ACS880-07-0271A-7 power rating: The power rating is as per NEC Table 42.1. However, the drive can be used for a typical 4-pole motor rated to 300 hp meeting NEMA MG 1 Table 12-11 minimum efficiency standard (EPA efficiency electrical motors) if motor full load current is not more than 271 A.

Note 5: For the dimensions of ACS880-07 please see page 37.

Ratings, types and voltages

ACS880-11, wall-mounted regenerative drive modules



ACS880-11 $U_N = 400\text{ V}$ (range 380 to 415 V). The power ratings are valid at nominal voltage 400 V (3 to 110 kW).

| Drive type | Frame size | Nominal ratings | | | Light overload use | | Heavy-duty use | |
|------------------|------------|-----------------|---------------|------------|--------------------|---------------|----------------|---------------|
| | | I_N (A) | I_{MAX} (A) | P_N (kW) | I_{Ld} (A) | P_{Ld} (kW) | I_{Hd} (A) | P_{Hd} (kW) |
| ACS880-11-09A4-3 | R3 | 10 | 13.6 | 4 | 9.5 | 4 | 8 | 3 |
| ACS880-11-12A6-3 | R3 | 12.9 | 17 | 5.5 | 12 | 5.5 | 10 | 4 |
| ACS880-11-017A-3 | R3 | 17 | 21.9 | 7.5 | 16 | 7.5 | 12.9 | 5.4 |
| ACS880-11-025A-3 | R3 | 25 | 28.8 | 11 | 24 | 11 | 17 | 7.5 |
| ACS880-11-032A-3 | R6 | 32 | 42.5 | 15 | 30 | 15 | 25 | 11 |
| ACS880-11-038A-3 | R6 | 38 | 54.4 | 18.5 | 36 | 18.5 | 32 | 15 |
| ACS880-11-045A-3 | R6 | 45 | 64.6 | 22 | 43 | 22 | 38 | 18.5 |
| ACS880-11-061A-3 | R6 | 61 | 76.5 | 30 | 58 | 30 | 45 | 22 |
| ACS880-11-072A-3 | R6 | 72 | 103.7 | 37 | 68 | 37 | 61 | 30 |
| ACS880-11-087A-3 | R6 | 87 | 122.4 | 45 | 83 | 45 | 72 | 37 |
| ACS880-11-105A-3 | R8 | 105 | 148 | 55 | 100 | 55 | 87 | 45 |
| ACS880-11-145A-3 | R8 | 145 | 178 | 75 | 138 | 75 | 105 | 55 |
| ACS880-11-169A-3 | R8 | 169 | 247 | 90 | 161 | 90 | 145 | 75 |
| ACS880-11-206A-3 | R8 | 206 | 287 | 110 | 196 | 110 | 169 | 90 |

ACS880-11 $U_N = 500\text{ V}$ (range 380 to 500 V). The power ratings are valid at nominal voltage 500 V (2.2 to 110 kW).

| Drive type | Frame size | Nominal ratings | | | Light overload use | | Heavy-duty use | |
|------------------|------------|-----------------|---------------|------------|--------------------|---------------|----------------|---------------|
| | | I_N (A) | I_{MAX} (A) | P_N (kW) | I_{Ld} (A) | P_{Ld} (kW) | I_{Hd} (A) | P_{Hd} (kW) |
| ACS880-11-07A6-5 | R3 | 7.6 | 9.5 | 4 | 7.2 | 4 | 5.2 | 2.2 |
| ACS880-11-11A0-5 | R3 | 11 | 13.8 | 5.5 | 10.4 | 5.5 | 7.6 | 4 |
| ACS880-11-014A-5 | R3 | 14 | 18.7 | 7.5 | 13 | 7.5 | 11 | 5.5 |
| ACS880-11-021A-5 | R3 | 21 | 26.3 | 11 | 19 | 11 | 14 | 7.5 |
| ACS880-11-027A-5 | R6 | 27 | 35.7 | 15 | 26 | 15 | 21 | 11 |
| ACS880-11-034A-5 | R6 | 34 | 45.9 | 18.5 | 32 | 18.5 | 27 | 15 |
| ACS880-11-040A-5 | R6 | 40 | 57.8 | 22 | 38 | 22 | 34 | 18.5 |
| ACS880-11-052A-5 | R6 | 52 | 68 | 30 | 49 | 30 | 40 | 22 |
| ACS880-11-065A-5 | R6 | 65 | 88.4 | 37 | 62 | 37 | 52 | 30 |
| ACS880-11-077A-5 | R6 | 77 | 110.5 | 45 | 73 | 45 | 65 | 37 |
| ACS880-11-101A-5 | R8 | 101 | 148 | 55 | 91 | 55 | 77 | 45 |
| ACS880-11-124A-5 | R8 | 124 | 178 | 75 | 118 | 75 | 96 | 55 |
| ACS880-11-156A-5 | R8 | 156 | 247 | 90 | 148 | 90 | 124 | 75 |
| ACS880-11-180A-5 | R8 | 180 | 287 | 110 | 171 | 110 | 156 | 90 |

Nominal ratings I_N Rated current available continuously without overloadability at 40 °C. P_N Typical motor power in no-overload use.**Maximum output current** I_{max} Maximum output current. Available for 10 seconds at start, then as long as allowed by drive temperature.**Light-overload use** I_{Ld} Continuous current allowing 110% I_{Ld} for 1 minute every 5 minutes at 40 °C. P_{Ld} Typical motor power in light-overload use.**Heavy-duty use** I_{Hd} Continuous current allowing 150% I_{Hd} for 1 minute every 5 minutes at 40 °C. P_{Hd} Typical motor power in heavy-duty use.

The ratings apply at 40 °C ambient temperature.

At higher temperatures (up to 55 °C) the derating is 1%/1 °C.

Ratings, types and voltages

ACS880-14, regenerative drive modules



ACS880-14 $U_N = 400\text{ V}$ (range 380 to 415 V). The power ratings are valid at nominal voltage 400 V (110 to 355 kW).

| Drive type | Frame size | Nominal ratings | | | Light overload use | | Heavy-duty use | |
|------------------|------------|-----------------|---------------|------------|--------------------|---------------|----------------|---------------|
| | | I_N (A) | I_{max} (A) | P_N (kW) | I_{Ld} (A) | P_{Ld} (kW) | I_{Hd} (A) | P_{Hd} (kW) |
| ACS880-14-246A-3 | R11 | 246 | 350 | 132 | 234 | 132 | 206 | 110 |
| ACS880-14-293A-3 | R11 | 293 | 418 | 160 | 278 | 160 | 246 | 132 |
| ACS880-14-363A-3 | R11 | 363 | 498 | 200 | 345 | 200 | 293 | 160 |
| ACS880-14-442A-3 | R11 | 442 | 621 | 250 | 420 | 250 | 363 | 200 |
| ACS880-14-505A-3 | R11 | 505 | 631 | 250 | 480 | 250 | 363 | 200 |
| ACS880-14-585A-3 | R11 | 585 | 751 | 315 | 556 | 315 | 442 | 250 |
| ACS880-14-650A-3 | R11 | 650 | 859 | 355 | 618 | 355 | 505 | 250 |

ACS880-14 $U_N = 500\text{ V}$ (range 380 to 500 V). The power ratings are valid at nominal voltage 500 V (110 to 355 kW).

| Drive type | Frame size | Nominal ratings | | | Light overload use | | Heavy-duty use | |
|------------------|------------|-----------------|---------------|------------|--------------------|---------------|----------------|---------------|
| | | I_N (A) | I_{max} (A) | P_N (kW) | I_{Ld} (A) | P_{Ld} (kW) | I_{Hd} (A) | P_{Hd} (kW) |
| ACS880-14-240A-5 | R11 | 240 | 350 | 132 | 228 | 132 | 180 | 110 |
| ACS880-14-260A-5 | R11 | 260 | 418 | 160 | 247 | 160 | 240 | 132 |
| ACS880-14-361A-5 | R11 | 361 | 542 | 200 | 343 | 200 | 260 | 160 |
| ACS880-14-414A-5 | R11 | 414 | 614 | 250 | 393 | 250 | 361 | 200 |
| ACS880-14-460A-5 | R11 | 460 | 660 | 315 | 450 | 315 | 414 | 250 |
| ACS880-14-503A-5 | R11 | 503 | 725 | 355 | 492 | 355 | 460 | 315 |

ACS880-14 $U_N = 690\text{ V}$ (range 525 to 690 V). The power ratings are valid at nominal voltage 690 V (110 to 400 kW).

| Drive type | Frame size | Nominal ratings | | | Light overload use | | Heavy-duty use | |
|------------------|------------|-----------------|---------------|------------|--------------------|---------------|----------------|---------------|
| | | I_N (A) | I_{max} (A) | P_N (kW) | I_{Ld} (A) | P_{Ld} (kW) | I_{Hd} (A) | P_{Hd} (kW) |
| ACS880-14-142A-7 | R11 | 142 | 250 | 132 | 135 | 132 | 119 | 110 |
| ACS880-14-174A-7 | R11 | 174 | 274 | 160 | 165 | 160 | 142 | 132 |
| ACS880-14-210A-7 | R11 | 210 | 384 | 200 | 200 | 200 | 174 | 160 |
| ACS880-14-271A-7 | R11 | 271 | 411 | 250 | 257 | 250 | 210 | 200 |
| ACS880-14-330A-7 | R11 | 330 | 480 | 315 | 320 | 315 | 271 | 250 |
| ACS880-14-370A-7 | R11 | 370 | 520 | 355 | 360 | 355 | 330 | 315 |
| ACS880-14-430A-7 | R11 | 430 | 520 | 400 | 420 | 400 | 370 | 355 |

Ratings, types and voltages

ACS880-17, cabinet-built regenerative



ACS880-17 $U_N = 400\text{ V}$ (range 380 to 415 V). The power ratings are valid at nominal voltage 400 V (45 to 1400 kW).

| Drive type | Frame size | Nominal ratings | | | Light overload use | | Heavy-duty use | |
|-------------------|------------|-----------------|---------------|------------|--------------------|---------------|----------------|---------------|
| | | I_N (A) | I_{MAX} (A) | P_N (kW) | I_{Ld} (A) | P_{Ld} (kW) | I_{Hd} (A) | P_{Hd} (kW) |
| ACS880-17-0105A-3 | R8 | 105 | 148 | 55 | 100 | 55 | 87 | 45 |
| ACS880-17-0145A-3 | R8 | 145 | 178 | 75 | 138 | 75 | 105 | 55 |
| ACS880-17-0169A-3 | R8 | 169 | 247 | 90 | 161 | 90 | 145 | 75 |
| ACS880-17-0206A-3 | R8 | 206 | 287 | 110 | 196 | 110 | 169 | 90 |
| ACS880-17-0293A-3 | R11 | 293 | 418 | 160 | 278 | 160 | 246 | 132 |
| ACS880-17-0363A-3 | R11 | 363 | 498 | 200 | 345 | 200 | 293 | 160 |
| ACS880-17-0442A-3 | R11 | 442 | 621 | 250 | 420 | 250 | 363 | 200 |
| ACS880-17-0505A-3 | R11 | 505 | 631 | 250 | 480 | 250 | 363 | 200 |
| ACS880-17-0585A-3 | R11 | 585 | 751 | 315 | 556 | 315 | 442 | 250 |
| ACS880-17-0650A-3 | R11 | 650 | 859 | 355 | 618 | 355 | 505 | 250 |

ACS880-17 $U_N = 500\text{ V}$ (range 380 to 500 V). The power ratings are valid at nominal voltage 500 V (45 to 1600 kW).

| Drive type | Frame size | Nominal ratings | | | Light overload use | | Heavy-duty use | |
|-------------------|------------|-----------------|---------------|------------|--------------------|---------------|----------------|---------------|
| | | I_N (A) | I_{MAX} (A) | P_N (kW) | I_{Ld} (A) | P_{Ld} (kW) | I_{Hd} (A) | P_{Hd} (kW) |
| ACS880-17-0101A-5 | R8 | 101 | 148 | 55 | 91 | 55 | 77 | 45 |
| ACS880-17-0124A-5 | R8 | 124 | 178 | 75 | 118 | 75 | 96 | 55 |
| ACS880-17-0156A-5 | R8 | 156 | 247 | 90 | 148 | 90 | 124 | 75 |
| ACS880-17-0180A-5 | R8 | 180 | 287 | 110 | 171 | 110 | 156 | 90 |
| ACS880-17-0260A-5 | R11 | 260 | 418 | 160 | 247 | 160 | 240 | 132 |
| ACS880-17-0361A-5 | R11 | 361 | 542 | 200 | 343 | 200 | 260 | 160 |
| ACS880-17-0414A-5 | R11 | 414 | 614 | 250 | 393 | 250 | 361 | 200 |
| ACS880-17-0460A-5 | R11 | 460 | 660 | 315 | 450 | 315 | 414 | 250 |
| ACS880-17-0503A-5 | R11 | 503 | 725 | 355 | 492 | 355 | 460 | 315 |

ACS880-17 $U_N = 690\text{ V}$ (range 525 to 690 V). The power ratings are valid at nominal voltage 690 V (132 to 3200 kW).

| Drive type | Frame size | Nominal ratings | | | Light overload use | | Heavy-duty use | |
|-------------------|------------|-----------------|---------------|------------|--------------------|---------------|----------------|---------------|
| | | I_N (A) | I_{MAX} (A) | P_N (kW) | I_{Ld} (A) | P_{Ld} (kW) | I_{Hd} (A) | P_{Hd} (kW) |
| ACS880-17-0174A-7 | R11 | 174 | 274 | 160 | 165 | 160 | 142 | 132 |
| ACS880-17-0210A-7 | R11 | 210 | 384 | 200 | 200 | 200 | 174 | 160 |
| ACS880-17-0271A-7 | R11 | 271 | 411 | 250 | 257 | 250 | 210 | 200 |
| ACS880-17-0330A-7 | R11 | 330 | 480 | 315 | 320 | 315 | 271 | 250 |
| ACS880-17-0370A-7 | R11 | 370 | 520 | 355 | 360 | 355 | 330 | 315 |
| ACS880-17-0430A-7 | R11 | 430 | 520 | 400 | 420 | 400 | 370 | 355 |

Nominal ratings I_N Rated current available continuously without overloadability at 40 °C. P_N Typical motor power in no-overload use.**Maximum output current** I_{max} Maximum output current. Available for 10 seconds at start, then as long as allowed by drive temperature.**Light-overload use** I_{Ld} Continuous current allowing 110% I_{Ld} for 1 minute every 5 minutes at 40 °C. P_{Ld} Typical motor power in light-overload use.**Heavy-duty use** I_{Hd} Continuous current allowing 150% I_{Hd} for 1 minute every 5 minutes at 40 °C. P_{Hd} Typical motor power in heavy-duty use.

The ratings apply at 40 °C ambient temperature.

At higher temperatures (up to 50 °C) the derating is 1%/1 °C. Operation above 150 Hz might require type-specific derating.

Ratings, types and voltages

ACS880-31, wall-mounted
ultra-low harmonic



ACS880-31 **$U_N = 400\text{ V}$ (range 380 to 415 V). The power ratings are valid at nominal voltage 400 V (3 to 110 kW).**

| Drive type | Frame size | Nominal ratings | | | Light overload use | | Heavy-duty use | |
|------------------|------------|-----------------|---------------|------------|--------------------|---------------|----------------|---------------|
| | | I_N (A) | I_{MAX} (A) | P_N (kW) | I_{Ld} (A) | P_{Ld} (kW) | I_{Hd} (A) | P_{Hd} (kW) |
| ACS880-31-09A4-3 | R3 | 10 | 13.6 | 4 | 9.5 | 4 | 8 | 3 |
| ACS880-31-12A6-3 | R3 | 12.9 | 17 | 5.5 | 12 | 5.5 | 10 | 4 |
| ACS880-31-017A-3 | R3 | 17 | 21.9 | 7.5 | 16 | 7.5 | 12.9 | 5.4 |
| ACS880-31-025A-3 | R3 | 25 | 28.8 | 11 | 24 | 11 | 17 | 7.5 |
| ACS880-31-032A-3 | R6 | 32 | 42.5 | 15 | 30 | 15 | 25 | 11 |
| ACS880-31-038A-3 | R6 | 38 | 54.4 | 18.5 | 36 | 18.5 | 32 | 15 |
| ACS880-31-045A-3 | R6 | 45 | 64.6 | 22 | 43 | 22 | 38 | 18.5 |
| ACS880-31-061A-3 | R6 | 61 | 76.5 | 30 | 58 | 30 | 45 | 22 |
| ACS880-31-072A-3 | R6 | 72 | 103.7 | 37 | 68 | 37 | 61 | 30 |
| ACS880-31-087A-3 | R6 | 87 | 122.4 | 45 | 83 | 45 | 72 | 37 |
| ACS880-31-105A-3 | R8 | 105 | 148 | 55 | 100 | 55 | 87 | 45 |
| ACS880-31-145A-3 | R8 | 145 | 178.3 | 75 | 138 | 75 | 105 | 55 |
| ACS880-31-169A-3 | R8 | 169 | 246.5 | 90 | 161 | 90 | 145 | 75 |
| ACS880-31-206A-3 | R8 | 206 | 287.3 | 110 | 196 | 110 | 169 | 90 |

ACS880-31 **$U_N = 500\text{ V}$ (range 380 to 500 V). The power ratings are valid at nominal voltage 500 V (2.2 to 110 kW).**

| Drive type | Frame size | Nominal ratings | | | Light overload use | | Heavy-duty use | |
|------------------|------------|-----------------|---------------|------------|--------------------|---------------|----------------|---------------|
| | | I_N (A) | I_{MAX} (A) | P_N (kW) | I_{Ld} (A) | P_{Ld} (kW) | I_{Hd} (A) | P_{Hd} (kW) |
| ACS880-31-07A6-5 | R3 | 7.6 | 9.5 | 4 | 7.2 | 4 | 5.2 | 2.2 |
| ACS880-31-11A0-5 | R3 | 11 | 13.8 | 5.5 | 10.4 | 5.5 | 7.6 | 4 |
| ACS880-31-014A-5 | R3 | 14 | 18.7 | 7.5 | 13 | 7.5 | 11 | 5.5 |
| ACS880-31-021A-5 | R3 | 21 | 26.3 | 11 | 19 | 11 | 14 | 7.5 |
| ACS880-31-027A-5 | R6 | 27 | 35.7 | 15 | 26 | 15 | 21 | 11 |
| ACS880-31-034A-5 | R6 | 34 | 45.9 | 18.5 | 32 | 18.5 | 27 | 15 |
| ACS880-31-040A-5 | R6 | 40 | 57.8 | 22 | 38 | 22 | 34 | 18.5 |
| ACS880-31-052A-5 | R6 | 52 | 68 | 30 | 49 | 30 | 40 | 22 |
| ACS880-31-065A-5 | R6 | 65 | 88.4 | 37 | 62 | 37 | 52 | 30 |
| ACS880-31-077A-5 | R6 | 77 | 110.5 | 45 | 73 | 45 | 65 | 37 |
| ACS880-31-101A-5 | R8 | 101 | 148 | 55 | 91 | 55 | 77 | 45 |
| ACS880-31-124A-5 | R8 | 124 | 178 | 75 | 118 | 75 | 96 | 55 |
| ACS880-31-156A-5 | R8 | 156 | 247 | 90 | 148 | 90 | 124 | 75 |
| ACS880-31-180A-5 | R8 | 180 | 287 | 110 | 171 | 110 | 156 | 90 |

Nominal ratings I_N Rated current available continuously without overloadability at 40 °C. P_N Typical motor power in no-overload use.**Maximum output current** I_{max} Maximum output current. Available for 10 seconds at start, then as long as allowed by drive temperature.**Light-overload use** I_{Ld} Continuous current allowing 110% I_{Ld} for 1 minute every 5 minutes at 40 °C. P_{Ld} Typical motor power in light-overload use.**Heavy-duty use** I_{Hd} Continuous current allowing 150% I_{Hd} for 1 minute every 5 minutes at 40 °C. P_{Hd} Typical motor power in heavy-duty use.

The ratings apply at 40 °C ambient temperature.

At higher temperatures (up to 55 °C) the derating is 1%/1 °C.

Ratings, types and voltages

ACS880-34, ultra-low harmonic drive modules



ACS880-34 $U_N = 400\text{ V}$ (range 380 to 415 V). The power ratings are valid at nominal voltage 400 V (110 to 355 kW).

| Drive type | Frame size | Nominal ratings | | | Light overload use | | Heavy-duty use | |
|------------------|------------|-----------------|---------------|------------|--------------------|---------------|----------------|---------------|
| | | I_N (A) | I_{max} (A) | P_N (kW) | I_{Ld} (A) | P_{Ld} (kW) | I_{Hd} (A) | P_{Hd} (kW) |
| ACS880-34-246A-3 | R11 | 246 | 350 | 132 | 234 | 132 | 206 | 110 |
| ACS880-34-293A-3 | R11 | 293 | 418 | 160 | 278 | 160 | 246 | 132 |
| ACS880-34-363A-3 | R11 | 363 | 498 | 200 | 345 | 200 | 293 | 160 |
| ACS880-34-442A-3 | R11 | 442 | 545 | 250 | 420 | 250 | 363 | 200 |
| ACS880-34-505A-3 | R11 | 505 | 560 | 250 | 480 | 250 | 363 | 200 |
| ACS880-34-585A-3 | R11 | 585 | 730 | 315 | 556 | 315 | 442 | 250 |
| ACS880-34-650A-3 | R11 | 650 | 758 | 355 | 618 | 355 | 505 | 250 |

ACS880-34 $U_N = 500\text{ V}$ (range 380 to 500 V). The power ratings are valid at nominal voltage 500 V (110 to 355 kW).

| Drive type | Frame size | Nominal ratings | | | Light overload use | | Heavy-duty use | |
|------------------|------------|-----------------|---------------|------------|--------------------|---------------|----------------|---------------|
| | | I_N (A) | I_{max} (A) | P_N (kW) | I_{Ld} (A) | P_{Ld} (kW) | I_{Hd} (A) | P_{Hd} (kW) |
| ACS880-34-240A-5 | R11 | 240 | 350 | 132 | 228 | 132 | 180 | 110 |
| ACS880-34-260A-5 | R11 | 260 | 418 | 160 | 247 | 160 | 240 | 132 |
| ACS880-34-361A-5 | R11 | 361 | 542 | 200 | 343 | 200 | 260 | 160 |
| ACS880-34-414A-5 | R11 | 414 | 542 | 250 | 393 | 250 | 361 | 200 |
| ACS880-34-460A-5 | R11 | 460 | 560 | 315 | 450 | 315 | 414 | 250 |
| ACS880-34-503A-5 | R11 | 503 | 725 | 355 | 492 | 355 | 460 | 315 |

ACS880-34 $U_N = 690\text{ V}$ (range 525 to 690 V). The power ratings are valid at nominal voltage 690 V (110 to 400 kW).

| Drive type | Frame size | Nominal ratings | | | Light overload use | | Heavy-duty use | |
|------------------|------------|-----------------|---------------|------------|--------------------|---------------|----------------|---------------|
| | | I_N (A) | I_{max} (A) | P_N (kW) | I_{Ld} (A) | P_{Ld} (kW) | I_{Hd} (A) | P_{Hd} (kW) |
| ACS880-34-142A-7 | R11 | 142 | 250 | 132 | 135 | 132 | 119 | 110 |
| ACS880-34-174A-7 | R11 | 174 | 274 | 160 | 165 | 160 | 142 | 132 |
| ACS880-34-210A-7 | R11 | 210 | 384 | 200 | 200 | 200 | 174 | 160 |
| ACS880-34-271A-7 | R11 | 271 | 411 | 250 | 257 | 250 | 210 | 200 |
| ACS880-34-330A-7 | R11 | 330 | 480 | 315 | 320 | 315 | 271 | 250 |
| ACS880-34-370A-7 | R11 | 370 | 520 | 355 | 360 | 355 | 330 | 315 |
| ACS880-34-430A-7 | R11 | 430 | 520 | 400 | 420 | 400 | 370 | 355 |

Ratings, types and voltages

ACS880-37, cabinet-built
ultra-low harmonic



ACS880-37 $U_N = 400\text{ V}$ (range 380 to 415 V). The power ratings are valid at nominal voltage 400 V (45 to 1400 kW).

| Drive type | Frame size | Nominal ratings | | | Light overload use | | Heavy-duty use | |
|-------------------|------------|-----------------|---------------|------------|--------------------|---------------|----------------|---------------|
| | | I_N (A) | I_{MAX} (A) | P_N (kW) | I_{Ld} (A) | P_{Ld} (kW) | I_{Hd} (A) | P_{Hd} (kW) |
| ACS880-37-0105A-3 | R8 | 105 | 148 | 55 | 100 | 55 | 87 | 45 |
| ACS880-37-0145A-3 | R8 | 145 | 178 | 75 | 138 | 75 | 105 | 55 |
| ACS880-37-0169A-3 | R8 | 169 | 247 | 90 | 161 | 90 | 145 | 75 |
| ACS880-37-0206A-3 | R8 | 206 | 287 | 110 | 196 | 110 | 169 | 90 |
| ACS880-37-0293A-3 | R11 | 293 | 418 | 160 | 278 | 160 | 246 | 132 |
| ACS880-37-0363A-3 | R11 | 363 | 498 | 200 | 345 | 200 | 293 | 160 |
| ACS880-37-0442A-3 | R11 | 442 | 621 | 250 | 420 | 250 | 363 | 200 |
| ACS880-37-0505A-3 | R11 | 505 | 631 | 250 | 480 | 250 | 363 | 200 |
| ACS880-37-0585A-3 | R11 | 585 | 751 | 315 | 556 | 315 | 442 | 250 |
| ACS880-37-0650A-3 | R11 | 650 | 859 | 355 | 618 | 355 | 505 | 250 |

ACS880-37 $U_N = 500\text{ V}$ (range 380 to 500 V). The power ratings are valid at nominal voltage 500 V (45 to 1600 kW).

| Drive type | Frame size | Nominal ratings | | | Light overload use | | Heavy-duty use | |
|-------------------|------------|-----------------|---------------|------------|--------------------|---------------|----------------|---------------|
| | | I_N (A) | I_{MAX} (A) | P_N (kW) | I_{Ld} (A) | P_{Ld} (kW) | I_{Hd} (A) | P_{Hd} (kW) |
| ACS880-37-0101A-5 | R8 | 101 | 148 | 55 | 91 | 55 | 77 | 45 |
| ACS880-37-0124A-5 | R8 | 124 | 178 | 75 | 118 | 75 | 96 | 55 |
| ACS880-37-0156A-5 | R8 | 156 | 247 | 90 | 148 | 90 | 124 | 75 |
| ACS880-37-0180A-5 | R8 | 180 | 287 | 110 | 171 | 110 | 156 | 90 |
| ACS880-37-0260A-5 | R11 | 260 | 418 | 160 | 247 | 160 | 240 | 132 |
| ACS880-37-0361A-5 | R11 | 361 | 542 | 200 | 343 | 200 | 260 | 160 |
| ACS880-37-0414A-5 | R11 | 414 | 614 | 250 | 393 | 250 | 361 | 200 |
| ACS880-37-0460A-5 | R11 | 460 | 660 | 315 | 450 | 315 | 414 | 250 |
| ACS880-37-0503A-5 | R11 | 503 | 725 | 355 | 492 | 355 | 460 | 315 |

ACS880-37 $U_N = 690\text{ V}$ (range 525 to 690 V). The power ratings are valid at nominal voltage 690 V (132 to 3200 kW).

| Drive type | Frame size | Nominal ratings | | | Light overload use | | Heavy-duty use | |
|-------------------|------------|-----------------|---------------|------------|--------------------|---------------|----------------|---------------|
| | | I_N (A) | I_{MAX} (A) | P_N (kW) | I_{Ld} (A) | P_{Ld} (kW) | I_{Hd} (A) | P_{Hd} (kW) |
| ACS880-37-0174A-7 | R11 | 174 | 274 | 160 | 165 | 160 | 142 | 132 |
| ACS880-37-0210A-7 | R11 | 210 | 384 | 200 | 200 | 200 | 174 | 160 |
| ACS880-37-0271A-7 | R11 | 271 | 411 | 250 | 257 | 250 | 210 | 200 |
| ACS880-37-0330A-7 | R11 | 330 | 480 | 315 | 320 | 315 | 271 | 250 |
| ACS880-37-0370A-7 | R11 | 370 | 520 | 355 | 360 | 355 | 330 | 315 |
| ACS880-37-0430A-7 | R11 | 430 | 520 | 400 | 420 | 400 | 370 | 355 |

Nominal ratings I_N Rated current available continuously without overloadability at 40 °C. P_N Typical motor power in no-overload use.**Maximum output current** I_{max} Maximum output current. Available for 10 seconds at start, then as long as allowed by drive temperature.**Light-overload use** I_{Ld} Continuous current allowing 110% I_{Ld} for 1 minute every 5 minutes at 40 °C. P_{Ld} Typical motor power in light-overload use.**Heavy-duty use** I_{Hd} Continuous current allowing 150% I_{Hd} for 1 minute every 5 minutes at 40 °C. P_{Hd} Typical motor power in heavy-duty use.

The ratings apply at 40 °C ambient temperature.

At higher temperatures (up to 50 °C) the derating is 1%/1 °C. Operation above 150 Hz might require type-specific derating.

¹⁾ Values to be confirmed upon full sales release of the product. Please contact ABB for further information.

Installation directions

Compact with a small footprint

Free space requirements

| ACS380 | | | |
|------------|------------|------------|---------------------------------|
| Frame size | Above (mm) | Below (mm) | On the sides ¹⁾ (mm) |
| R0 to R4 | 75 | 75 | 0 |
| ACS480 | | | |
| R1 to R4 | 75 | 75 | 0 |

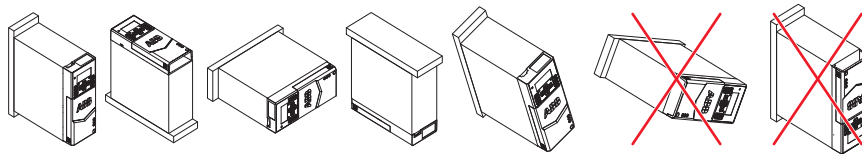

- Make sure that there is a minimum of 75 mm of free space at the top and bottom of the drive (at the cooling air inlet and outlet).
 - You can install several drives side by side. Note that side-mounted options require 20 mm of space on the right side of the drive.
 - Install R0 drives upright. R0 drive do not have a cooling fan.
 - You can install R1, R2, R3 and R4 drives tilted by up to 90 degrees, from vertical to fully horizontal orientation.
 - Make sure that the cooling air exhaust at the top of the drive is not below the cooling air inlet at the bottom of the drive.
 - Make sure that the hot cooling air from a drive does not go into the cooling inlet of other equipment.
 - The drive has an IP20 ingress protection classification for cabinet installation.
- ¹⁾ You can install the modules side by side, but if you plan to install side-mounted options, leave 20 mm of space to the right side of the module.

ACS580-01

| Frame size | Vertical installation standalone | | | | Vertical installation side by side | | | |
|------------|---|---|--|-------------------|------------------------------------|----------------------------|------------------------------|--|
| | Above ^a IP21/IP55 (mm) | Below ^b IP21/IP55 (mm) | Beside ^c IP21/IP55 (mm) | | Above ^a (mm) | Below ^b (mm) | Between ^c (mm) | |
| R1 | 150/137 | 86/116 | 150 ²⁾ | 200 ²⁾ | 200 ²⁾ | 0 ²⁾ | | |
| R2 | 150/137 | 86/116 | 150 ²⁾ | 200 ²⁾ | 200 ²⁾ | 0 ²⁾ | | |
| R3 | 200 ²⁾ | 53 ²⁾ | 150 ²⁾ | 200 ²⁾ | 200 ²⁾ | 0 ²⁾ | | |
| R4 | 53 ²⁾ | 200 ²⁾ | 150 ²⁾ | 200 ²⁾ | 200 ²⁾ | 0 ²⁾ | | |
| R5 | 100 ²⁾ | 200 ²⁾ | 150 ²⁾ | 200 ²⁾ | 200 ²⁾ | 0 ²⁾ | | |
| R6 | 155 ²⁾ | 300 ²⁾ | 150 ²⁾ | 200 ²⁾ | 300 ²⁾ | 0 ²⁾ | | |
| R7 | 155 ²⁾ | 300 ²⁾ | 150 ²⁾ | 200 ²⁾ | 300 ²⁾ | 0 ²⁾ | | |
| R8 | 155 ²⁾ | 300 ²⁾ | 150 ²⁾ | 200 ²⁾ | 300 ²⁾ | 0 ²⁾ | | |
| R9 | 200 ²⁾ | 300 ²⁾ | 150 ²⁾ | 200 ²⁾ | 300 ²⁾ | 0 ²⁾ | | |

²⁾ Applies to IP21 and IP55

ACS580-01

| Frame size | Horizontal installation | | | |
|------------|---|---|---|---|
| | Above ^a IP21/IP55 (mm) | Below ^b IP21/IP55 (mm) | Side up ^c IP21/IP55 (mm) | Side down ^d IP21/IP55 (mm) |
| R1 | 150/137 | 86/116 | 30 ²⁾ | 200 ²⁾ |
| R2 | 150/137 | 86/116 | 30 ²⁾ | 200 ²⁾ |
| R3 | 200 ²⁾ | 53 ²⁾ | 30 ²⁾ | 200 ²⁾ |
| R4 | 30 ²⁾ | 200 ²⁾ | 30 ²⁾ | 200 ²⁾ |
| R5 | 30 ²⁾ | 200 ²⁾ | 30 ²⁾ | 200 ²⁾ |

²⁾ Applies to IP21 and IP55

Note 1: considering the original IP21 version Horizontal installation meets IP20 requirements only.

Note 2: considering the original IP55/type 12 version Horizontal installation meets IP21/type 1 requirements only.

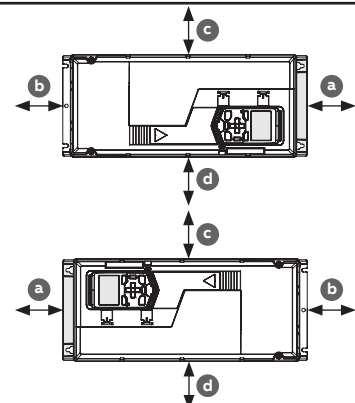

ACS580-04

| Frame size | Front (mm) | Back ¹⁾ (mm) | At the sides (mm) |
|--------------|------------|-------------------------|-------------------|
| All variants | 20 | 20 | 0 |

- The module can be installed in a cabinet with the following dimensions: width 500 mm, depth 600 mm, height 2000 mm
- If you install the drive module on its back, make sure that the hot cooling air that flows upwards from the module does not cause danger.

¹⁾ Space from the back wall

ACS580-07

| Frame size | Front ²⁾ (mm) | Above ¹⁾ (mm) | At the sides (mm) |
|--------------|--------------------------|--------------------------|-------------------|
| All variants | 150 | 400 | - |

- Leave some space at the side where the cabinet outmost hinges are to allow the doors to open sufficiently (w). The doors must open 120° to allow the drive module replacement.

¹⁾ Measured from the base plate of the cabinet top. Note: 320 mm is required for fan replacement of IP54 cabinets.
²⁾ 800 mm space needed in front of the cabinet for door opening.

ACS880-01

| Frame size | Front (mm) | Above (mm) | Bottom ¹⁾ (mm) |
|--------------|------------|------------|---------------------------|
| All variants | 0 | 200 | 300 |

¹⁾ When measured from the drive base without the cable entry box.

ACS880-04/04XT

| Frame size | Front (mm) | Back (mm) | Above (mm) | Bottom ²⁾ (mm) |
|--------------|------------|-----------|------------|---------------------------|
| All variants | 20 | 20 | 300 | 0 |

- The module can be installed in a cabinet with the following dimensions: width 400 mm, depth 600 mm, height 2000 mm.

¹⁾ Space from the back wall
²⁾ When measured from the drive base without the cable entry box. If you install the drive module on its back, make sure that the hot cooling air that flows upwards from the module does not cause danger.

ACS880-04F/04FXT^{*)}

| Frame size | Above (mm) | Bottom (mm) |
|------------|------------|-------------|
| R11 | 200 | 200 |

^{*)} The modules can be installed side by side.

ACS880-07

| Frame size | Front ²⁾ (mm) | On the sides (mm) | Above ¹⁾ (mm) |
|--------------|--------------------------|-------------------|--------------------------|
| All variants | 150 | 20 | 400 |

¹⁾ Measured from the base plate of the cabinet top. Note: 320 mm (12.28 in.) is required for fan replacement of IP54 cabinets.
²⁾ 800 mm space needed in front of the cabinet for door opening.

ACS880-11/31 **Vertical installation. Do not install the drive upside down.**

| Frame size | Above (mm) | Below (mm) | Side (mm) |
|--------------|------------|------------|-----------|
| All variants | 200 | 300 | 0 |

- The drive must be installed on the wall. There are three alternative ways to install it:
 - Vertically alone. Do not install the drive upside down.
 - Vertically side by side.
 - Horizontally alone, IP21 only. See hardware manual.

ACS880-14/34

| Frame size | Above (mm) | Side (mm) | Back (mm) | Front (mm) |
|--------------|------------|-----------|-----------|------------|
| All variants | 350 | 0 | 20 | 20 |

- The module can be installed in a cabinet with the following dimensions: width 800 mm, depth 600 mm, height 2000 mm.

ACS880-17/37

| Frame size | Front (mm) | Side (mm) | Above ^{*)} (mm) |
|--------------|------------|-----------|--------------------------|
| All variants | 150 | - | 400 |

^{*)} Measured from the base plate of the cabinet top.

- The cabinet can be installed with its back against a wall, or back-to-back with another unit.
- Leave some space at the side where the cabinet outmost hinges are to allow the doors to open sufficiently. The doors must open 120° to allow supply or inverter module replacement

Dimensions

ACS380 IP20

| Frame size | Height (mm) | Width (mm) | Depth (mm) | Depth No cover (mm) | Depth Standard cover (mm) | Depth Bigger cover (mm) | Weight (kg) |
|------------|-------------|------------|------------|---------------------|---------------------------|-------------------------|-------------|
| R0 | 223 | 70 | 174 | 176 | 176 | 191 | 1.4 |
| R1 | 223 | 70 | 174 | 176 | 176 | 191 | 1.6 |
| R2 | 223 | 95 | 174 | 176 | 176 | 191 | 1.9 |
| R3 | 223 | 169 | 174 | 176 | 176 | 191 | 3.0 |
| R4 | 223 | 260 | 174 | 181 | 181 | 196 | 4.8 |

ACS480-04 IP20

| Frame size | Height (mm) | Width 1 *) (mm) | Width 2 *) (mm) | Depth 1 *) (mm) | Depth 2 *) (mm) | Weight (kg) |
|------------|-------------|-----------------|-----------------|-----------------|-----------------|-------------|
| R0 | 223 | 73.5 | 174 | 208.2 | 176 | 1.4 |
| R1 | 223 | 70 | 174 | 208.2 | 176 | 1.6 |
| R2 | 223 | 95 | 174 | 208.2 | 176 | 1.9 |
| R3 | 223 | 169 | 174 | 208.2 | 176 | 3.0 |
| R4 | 223 | 262 | 174 | 213.1 | 181 | 4.8 |

*) Dimensions without front hatch.

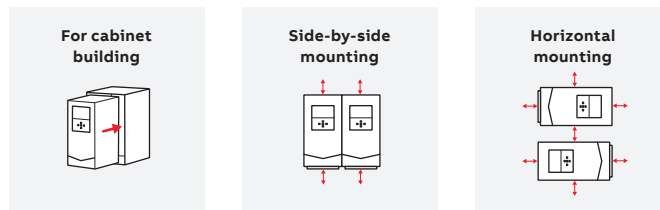

— ACS380 IP20

— ACS480-04 IP20



ACS580-01 IP21 (as standard)

| Frame size | Height 1 (mm) | Height 2 (mm) | Width (mm) | Depth (mm) | Weight (kg) |
|------------|---------------|---------------|------------|------------|-------------|
| R1 | 373 | 331 | 125 | 223 | 4.6 |
| R2 | 473 | 432 | 125 | 229 | 6.5 |
| R3 | 490 | 490 | 203 | 229 | 11.8 |
| R4 | 636 | 636 | 203 | 258 | 19 |
| R5 | 732 | 596 *) | 203 | 295 | 28.3 |
| R6 | 727 | 548 *) | 252 | 369 | 42.4 |
| R7 | 880 | 600 *) | 284 | 370 | 54 |
| R8 | 965 | 680 *) | 300 | 393 | 69 |
| R9 | 955 | 680 *) | 380 | 418 | 97 |

*) Removable conduit box with +P944 option

Height 1: is height with conduit box

Height 2: is height without conduit box

ACS580-01 Flange mounting dimensions

| Frame size | Height (mm) | Width (mm) | Offs. Out (mm) | Offs. In (mm) | Weight (kg) |
|------------|-------------|------------|----------------|---------------|-------------|
| R1 | 461 | 206 | 133 | 109 | 5.1 |
| R2 | 551 | 206 | 130 | 114 | 7.0 |
| R3 | 613 | 290 | 118 | 116 | 12.8 |
| R4 | 776 | 290 | 120 | 137 | 20.5 |
| R5 | 776 | 290 | 124 | 173 | 29.8 |
| R6 | 672 | 374 | 193 | 167 | 44.4 |
| R7 | 722 | 406 | 194 | 169 | 56.5 |
| R8 | 814 | 433 | 202 | 184 | 71.5 |
| R9 | 804 | 502 | 204 | 209 | 100 |

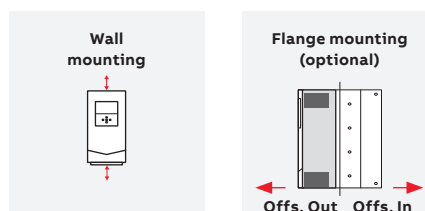

ACS580-01 IP55 (+B056)

| Frame size | Height 1 (mm) | Height 3 (mm) | Width (mm) | Depth (mm) | Weight (kg) |
|------------|---------------|---------------|------------|------------|-------------|
| R1 | 403 | 403 | 128 | 233 | 4.8/5.4 |
| R2 | 503 | 503 | 128 | 239 | 6.8/7.4 |
| R3 | 490 | 733 | 206 | 237 | 13/15 |
| R4 | 636 | 879 | 203 | 265 | 20/23.3 |
| R5 | 732 | 1023 | 203 | 320 | 29/33 |
| R6 | 727 | - | 252 | 380 | 43 |
| R7 | 880 | - | 284 | 381 | 56 |
| R8 | 965 | - | 300 | 452 | 77 |
| R9 | 955 | - | 380 | 477 | 103 |

Height 1: Overall height of the drive

Height 3: Height for options +F287 / +F316 / +E223

Note 1: options +F278 / +F316 / +E223 are available only for IP55 frames R1...R5

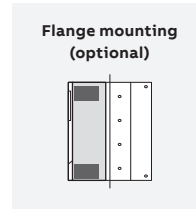
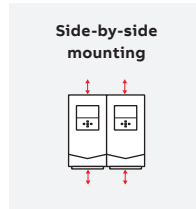
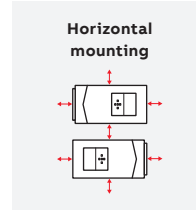
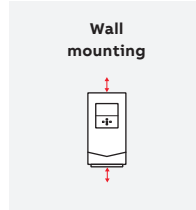

ACS580-04 IP00

| Frame size | Height (mm) | Width (mm) | Depth (mm) | Weight (kg) |
|------------|-------------|------------|------------|-------------|
| R10 | 1461.8 | 350 | 528.6 | 162 |
| R11 | 1661.8 | 350 | 528.6 | 200 |

ACS580-04 IP20 (+B051)

| Frame size | Height (mm) | Width (mm) | Depth (mm) | Weight (kg) |
|------------|-------------|------------|------------|-------------|
| R10 | 1462 | 350 | 528.6 | 162 |
| R11 | 1662 | 350 | 528.6 | 200 |

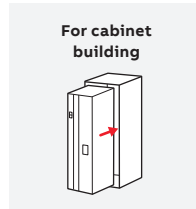

ACS580-04 IP00



ACS580-04 IP20 (+B051)



ACS580-07 IP21, standard

| Frame size | Height (mm) | Width (mm) | Depth (mm) | Weight (kg) |
|------------|-------------|------------|------------|-------------|
| R6 | 2145 | 430 | 673 | 210 |
| R7 | 2145 | 430 | 673 | 220 |
| R8 | 2145 | 530 | 673 | 255 |
| R9 | 2145 | 530 | 673 | 275 |
| R10 | 2145 | 830 | 698 | 535 |
| R11 | 2145 | 830 | 698 | 581 |

ACS580-07 IP21



ACS580-07IP42, IP54



ACS580-07 IP42, +B054

| Frame size | Height (mm) | Width (mm) | Depth (mm) | Weight (kg) |
|------------|-------------|------------|------------|-------------|
| R6 | 2145 | 430 | 673 | 210 |
| R7 | 2145 | 430 | 673 | 220 |
| R8 | 2145 | 530 | 673 | 255 |
| R9 | 2145 | 530 | 673 | 275 |
| R10 | 2145 | 830 | 698 | 535 |
| R11 | 2145 | 830 | 698 | 581 |

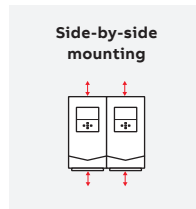

ACS580-07 IP54, +B055

| Frame size | Height (mm) | Width (mm) | Depth (mm) | Weight (kg) |
|------------|-------------|------------|------------|-------------|
| R6 | 2145 | 430 | 673 | 210 |
| R7 | 2145 | 430 | 673 | 220 |
| R8 | 2145 | 530 | 673 | 255 |
| R9 | 2145 | 530 | 673 | 275 |
| R10 | 2315 | 830 | 698 | 535 |
| R11 | 2315 | 830 | 698 | 581 |

Dimensions

ACS880-01 IP20

| Frame size | Height (mm) | Width (mm) | Depth (+P944) (mm) | Weight (kg) |
|------------|-------------------|------------|--------------------|-------------|
| R1 | 370 ^{*)} | 155 | 226 | 5.7 |
| R2 | 370 ^{*)} | 155 | 249 | 7.2 |
| R3 | 420 ^{*)} | 172 | 261 | 9.4 |
| R4 | 490 ^{*)} | 203 | 274 | 16.1 |
| R5 | 596 ^{*)} | 203 | 274 | 19.3 |
| R6 | 569 | 251 | 357 | 38.3 |
| R7 | 600 | 284 | 365 | 47.6 |
| R8 | 681 | 300 | 386 | 58.6 |
| R9 | 680 | 380 | 413 | 85.2 |

^{*)} Comes with main power clamp

For cabinet building



Flange mounting (optional)

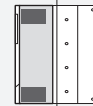

Side-by-side mounting

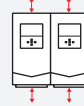

Horizontal mounting

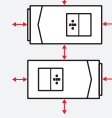

ACS880-01 IP21 (as standard)

| Frame size | Height (mm) | Width (mm) | Depth (mm) | Weight (kg) |
|------------|-------------|------------|------------|-------------|
| R1 | 405 | 155 | 226 | 6 |
| R2 | 405 | 155 | 249 | 8 |
| R3 | 471 | 172 | 261 | 10 |
| R4 | 573 | 203 | 274 | 18.5 |
| R5 | 730 | 203 | 274 | 23 |
| R6 | 726 | 251 | 357 | 45 |
| R7 | 880 | 284 | 365 | 55 |
| R8 | 963 | 300 | 386 | 70 |
| R9 | 955 | 380 | 413 | 98 |

Wall mounting



Horizontal mounting

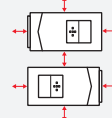

ACS880-01 IP55 (+B056)

| Frame size | Height (mm) | Width (mm) | Depth (mm) | Weight (kg) |
|------------|-------------|------------|------------|-------------|
| R1 | 450 | 162 | 295 | 6 |
| R2 | 450 | 162 | 315 | 8 |
| R3 | 525 | 180 | 327 | 10 |
| R4 | 576 | 203 | 344 | 18.5 |
| R5 | 730 | 203 | 344 | 23 |
| R6 | 726 | 251 | 421 | 45 |
| R7 | 880 | 284 | 423 | 55 |
| R8 | 963 | 300 | 452 | 72 |
| R9 | 955 | 380 | 477 | 100 |

Wall mounting



Flange mounting (optional)

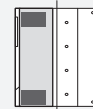

Side-by-side mounting

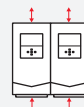

Horizontal mounting

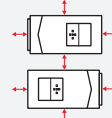

ACS880-04, ACS880-04XT (*) w/o pedestal and w/o IP20 shrouds and full-size terminals height is 179 mm less and width 45 mm less)

| Frame size | Height (mm) | Width (mm) | Depth (mm) | Weight (kg) |
|------------|--------------------|------------|------------|-------------|
| R10 | 1541 ^{*)} | 350 | 506 | 161 |
| R11 | 1741 ^{*)} | 350 | 506 | 199 |

ACS880-04XT standard drive module configuration

| Frame size | Height (mm) | Width (mm) | Depth (mm) | Weight (kg) |
|------------|-------------|------------|------------|-------------|
| R10 | 1462 | 305 | 506 | 156 |
| R11 | 1662 | 305 | 506 | 194 |

ACS880-04F

| Frame size | Height (mm) | Width (mm) | Depth (mm) | Weight (kg) |
|------------|--------------------|-------------------|-------------------|-------------|
| R11 | 1674 ^{*)} | 620 ^{*)} | 404 ^{*)} | 230 |

^{*)} w/o pedestal and w/o IP20 shrouds and full-size terminals height is 179 mm less and width 45 mm less.

Standard drive module configuration (including flange)

| Frame size | Height (mm) | Width (mm) | Depth (mm) | Weight (kg) |
|------------|-------------|------------|------------|-------------|
| R11 | 1733 | 620 | 477 | 224 |

ACS880-07, IP22/42/54

| Frame size | Height | | Width (mm) | Depth (mm) | Weight (kg) |
|------------|--------------|-----------|------------|-----------------------|-------------|
| | IP22/42 (mm) | IP54 (mm) | | | |
| R6 | 2145 | 2315 | 430 | 673/698 ¹⁾ | 240 |
| R7 | 2145 | 2315 | 430 | 673/698 ¹⁾ | 250 |
| R8 | 2145 | 2315 | 430 | 673/698 ¹⁾ | 265 |
| R9 | 2145 | 2315 | 830 | 698 | 375 |
| R10 | 2145 | 2315 | 830 | 698 | 530 |
| R11 | 2145 | 2315 | 830 | 698 | 580 |

¹⁾ 698 mm for IP54

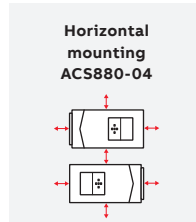
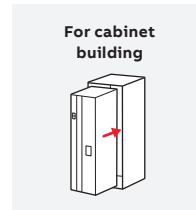
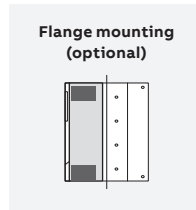
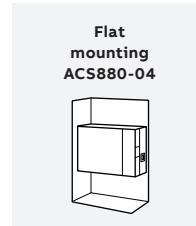
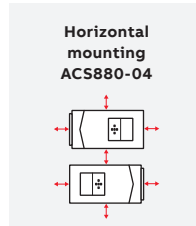
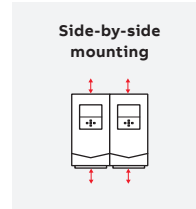
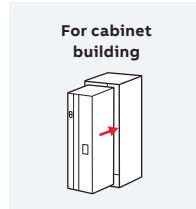

Dimensions

ACS880-11/31+P940, IP20

| Frame size | Height (mm) | Width (mm) | Depth (mm) | Weight (kg) |
|------------|-------------|------------|------------|-----------------------|
| R3 | 490 | 203 | 349 | 18.3 |
| R6 | 771 | 252 | 358 | 59 |
| R8 | 965 | 300 | 430 | 100/115 ¹⁾ |

¹⁾ 100 kg for 105A-3, 145A-3, 101A-5 and 124A-5.
115 kg for 169A-3, 206A-3, 156A-5 and 180A-5.



ACS880-14/34 frame R11, IP20

| Frame size | Height (mm) | Width (mm) | Depth (mm) | Weight (kg) |
|------------|-------------|------------|------------|-------------|
| R11 | 1741 | 713 | 512 | 365 |



ACS880-17/37, IP22/42/54*

| Frame size | Height | | Width (mm) | Depth (mm) | Weight (kg) |
|------------|--------------|-----------|------------|-------------------------|-------------|
| | IP22/42 (mm) | IP54 (mm) | | | |
| R8 | 2145 | 2315 | 430 | 673 / 698 ¹⁾ | 320 |
| R11 | 2145 | 2315 | 1230 | 698 | 750 |

¹⁾ 698 mm for IP54

*²⁾ Dimensions are for standard configuration including measures for door installed components. Plus code options can affect dimensions. For more information, please see dimensional drawings in hardware manual.





Local ACS880 1400.0 Rpm
Save money
Save energy
Save nerves
Exit Save all
Select

Stop

Loc/Rem

Start



?

Drive-based functional safety

Integrated safety



ABB's drive-based functional safety keeps application movement safe in industry:

- Integrated safety functions for most demanding applications – SIL 3/PL e
- Functions meet the requirements of the European Machinery Directive and relevant international functional safety standards
- Safe speed functions with or without an encoder
- Safe digital inputs and outputs
- PROFIsafe over PROFINET support
- Safety data library available for system design (VDMA and FSDT-01)
- Functional safety design tool (FSDT-01) for functional safety design and verification

Safety functions for industrial applications: (EN/IEC 61800-5-2)

- Safe torque off (STO)
- Safe stop 1 (SS1)
 - SS1-t (time controlled)
 - SS1-r (ramp monitored)
- Safe stop emergency (SSE)
- Safe brake control (SBC)
- Safely-limited speed (SLS)
- Safe maximum speed (SMS)
- Safe direction (SDI)
- Safe speed monitoring (SSM)
- Variable safely limited speed (varSLS)
- Prevention of unexpected start-up (POUS)

Software tools for safety

FSDT-01

FSDT-01 is a calculation and verification tool to verify SIL and PL levels of the safety functions, that are used for functional safety for machinery.

Graphical User interface for safety

Drive Composer pro offers a graphical user interface, which is used to configure FSO & FSE functional safety option modules.



Safety functions modules

Safety functions

FSO-12¹⁾



| |
|---------------------|
| STO |
| SS1 (SS1-t & SS1-r) |
| SSE |
| SBC |
| SLS |
| SMS |
| POUS |
| varSLS |

Safety functions

FSO-21¹⁾



| |
|-------------------------|
| STO |
| SS1 (SS1-t & SS1-r) |
| SSE |
| SBC |
| SLS |
| SMS |
| POUS |
| VarSLS |
| SDI (+ FSE-31 required) |
| SSM |

Safety encoder interface

FSE-31



Safe encoder interface for safety incremental HTL encoder

PROFIsafe safety functions

FSPS-21



| |
|--|
| STO |
| SS1-t |
| Integrated PROFIsafe over PROFINET support |

¹⁾ PROFIsafe over PROFINET support (requires FENA-21 or FPNO-21)

Every application requires safety

With the Drive-based functional safety solutions it is possible to make the applications safe either with safe stopping functions and/or with safe speed monitoring functions. The safe speed monitoring functions can be realized either with safe speed estimation or with the safety encoder.

Functional safety integrated into the drive

The easy-to-connect and -configure functional safety modules (FSO-12/-21 and FSPS-21) offer a wide range of safety functions that meet the European Machinery directive's and international functional safety requirements and standards, which can be integrated inside the drive. Compared to using external safety components, the drive-based functional safety comes with the supported functions, which are seamlessly integrated with the drive functionality. Thus reducing the implementation, cabling, and configuration as cost-effective solution. FSPS-21 PROFIsafe safety functions module requires no configuration for safety functions in the drive.

The FSO-12/21 with more advanced safety functions is set up by using the easy-to-use graphical user interface for safety in Drive composer pro PC tool.

FSPS-21 PROFIsafe safety functions module supports all-compatible ACS380, ACS580 and ACS880 products. FSO-12/21 safety functions modules are compatible with ACS880 industrial drives.

Design tool for simplifying your safety design

When designing a machine safety system, you must know what is required to achieve conformity. FSDT-01 design tool guides you to establish the target risk reduction (SIL/PL) and helps you in choosing the right safety devices to achieve the target. With the aid of the FSDT-01, you can pre-design and verify safety function design and generate supporting documentation. The tool supports both standards for the safety-related control systems of machinery, EN/ISO 13849-1 and EN/IEC 62061.

| Safety functions | | | | | | | | | | | | |
|------------------|-------------|-------------|----------------|----------------|----------------|------------|------------|--------------------|------------|--------------|--------------|--------------|
| | ACS380 | ACS480 | ACS580-01 | ACS580-04 | ACS580-07 | ACS880-01 | ACS880-04 | ACS880-04XT, 04FXT | ACS880-07 | ACS880-11/31 | ACS880-14/34 | ACS880-17/37 |
| | SIL 3/PL e | SIL 3/PL e | SIL 3/PL e | SIL /PL e | SIL 3/PL e | SIL 3/PL e | SIL 3 PL e | SIL 3/PL e | SIL 3/PL e | SIL 3/PL e | SIL 3/PL e | SIL 3/PL e |
| Voltage (V) | 1 ~ 200-240 | 1 ~ 200-240 | 3 ~ ph 380-480 | 3 ~ ph 380-480 | 3 ~ ph 380-480 | 208-240 | 208-240 | 380-415 | 380-415 | 3~ph 380-415 | 3~ph 380-415 | 3~ph 380-415 |
| | 3 ~ 200-240 | 3 ~ 200-240 | | | | 380-415 | 380-415 | 380-500 | 380-500 | 3~ph 380-500 | 3~ph 380-500 | 3~ph 380-500 |
| | 3 ~ 380-480 | 3 ~ 380-480 | | | | 380-500 | 380-500 | 525-690 | 525-690 | | 3~ph 525-690 | 3~ph 525-690 |
| | | | | | | 525-690 | 525-690 | | | | | |
| Power range | 0.25-22 | 0.25-22 | 0.75-250 | 250-500 | 75-500 | 0.55-250 | 250-2800 | 500-1200 | 45-2800 | 2.2-110 | 110-400 | 45-3200 |
| STO | ● | ● | ● | ● | ● | ● | ● | ● | ● | ● | ● | ● |
| SS1-t | 3 | o | 3 | 3 | 3 | 1, 2, 3 | 1, 2, 3 | 1, 2, 3 | 1, 2, 3 | 1, 2, 3 | 1, 2, 3 | 1, 2, 3 |
| SS1-r | o | o | o | o | o | 1, 2 | 1, 2 | 1, 2 | 1, 2 | 1, 2 | 1, 2 | 1, 2 |
| SBC | o | o | o | o | o | 1, 2 | 1, 2 | 1, 2 | 1, 2 | 1, 2 | 1, 2 | 1, 2 |
| SLS | o | o | o | o | o | 1, 2 | 1, 2 | 1, 2 | 1, 2 | 1, 2 | 1, 2 | 1, 2 |
| SSE | o | o | o | o | o | 1, 2 | 1, 2 | 1, 2 | 1, 2 | 1, 2 | 1, 2 | 1, 2 |
| SMS | o | o | o | o | o | 1, 2 | 1, 2 | 1, 2 | 1, 2 | 1, 2 | 1, 2 | 1, 2 |
| SDI | o | o | o | o | o | 2 | 2 | 2 | 2 | 2 | 2 | 2 |
| SSM | o | o | o | o | o | 2 | 2 | 2 | 2 | 2 | 2 | 2 |
| SMT*) | o | o | 5 | 5 | 5 | 6 | 6 | 6 | 6 | 6 | 6 | 6 |
| POUS | - | - | - | - | - | 1, 2 | 1, 2 | 1, 2 | 1, 2 | 1, 2 | 1, 2 | 1, 2 |
| PROFIsafe**) | 3 | - | 3 | 3 | 3 | 3, 4 | 3, 4 | 3, 4 | 3, 4 | 3, 4 | 3, 4 | 3, 4 |

● = Embedded
 o = Safety functions are possible with external safety devices connected to the STO in the drive
 *) Up to SIL2 / PL c
 **) PROFIsafe over PROFINET support

Available as an integrated drive option:
 1) FSO-12
 2) FSO-21 and FSE-31
 3) FSPS-21
 4) FSO-12 or- FSO-21 with FPNO-21 or FENA-21
 5) CPTC-02
 6) FPTC-01/-02

Typical safety functions

Safe Torque Off (STO)

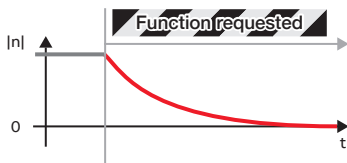

- **STO** is a standard safety function in all drives.
- Typically used for prevention of an unexpected start-up (ISO 14118) of machinery or for an emergency stop, fulfilling stop category 0 (EN/IEC 60204-1).

Safe stop emergency (SSE)

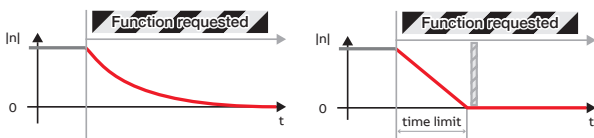

- **SSE** safety function is specifically designed for emergency stops.
- **SSE** can be configured to execute either STO or SS1 depending on which emergency stop is suitable for the system.
- For examples of this functionality see figures for STO and SS1.
- **SSE** is also used in case of safe limit hits in the FSO.

Safely-limited speed (SLS)

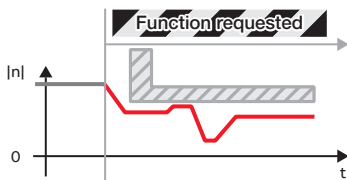

- **SLS** prevents motors from exceeding a defined speed limit.
- The SLS safety function can be used in applications such as decanters, mixers, conveyors or paper machines where the safe speed need to be monitored for safe intervention to the machine.
- It is possible to adjust the SLS limits “on fly” with varSLS functions.
- **varSLS** functionality requires safety PLC and profisafe connectivity.

Safe direction (SDI)

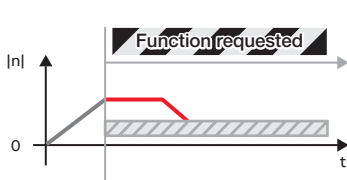

- **SDI** ensures that rotation of the motor is allowed only in the selected direction.
- **SDI** stops the drive first and then activates SDI control.

Safe stop 1 (SS1)

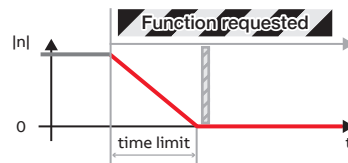

- **SS1** stops the motor safely, using a controlled ramp stop and then activates the STO function. The deceleration ramp is either monitored with the SS1-r or the deceleration time is monitored with the SS1-t.
- **SS1** is typically used in applications like rolling mills where motion must be stopped in a controlled manner before switching to a no-torque state.
- **SS1** can be used to implement an Emergency stop, fulfilling stop category 1 (EN/IEC 60204-1).

Safe brake control (SBC)

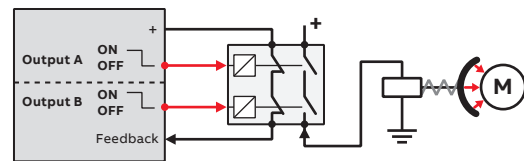

FSO-12 SAFETY MODULE BRAKE RELAY MECHANICAL BRAKE

- **SBC** provides a safe output signal to control a mechanical holding brake.
- Drills, cranes, winches, hoists, vertical conveyors and elevators that need external brake solutions require this type of safety function.
- Used always together with the STO function.

Safe maximum speed (SMS)

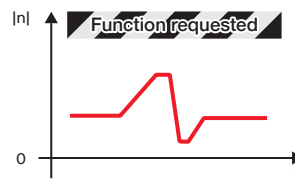

- **SMS** provides continuous monitoring of the maximum speed limit that shall not be exceeded in the application.

Safe speed monitoring (SSM)

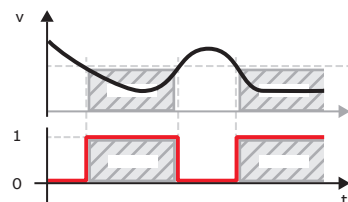

- **SSM** provides information that the speed is within the configured limits.

Prevention of unexpected start-up (POUS)

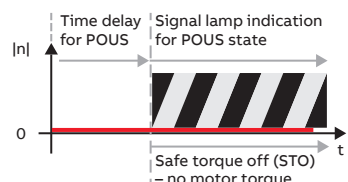

- The **POUS** function prevents the machine from starting unexpectedly.
- The **POUS** function activates the safe torque off (STO) function in the drive.

Example: SS1

Safety function module FSO-12, functionality cycle

0. Drive running

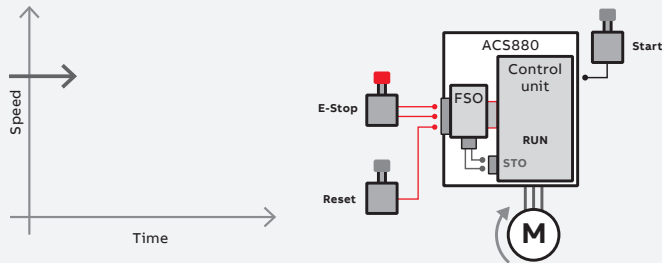

1. E-Stop down – safety function request to the FSO-12

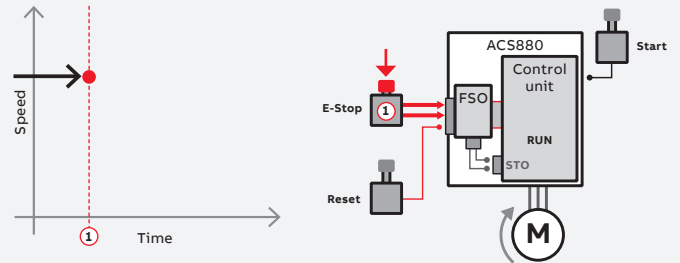

2. Safety function request to the drive / start of monitoring

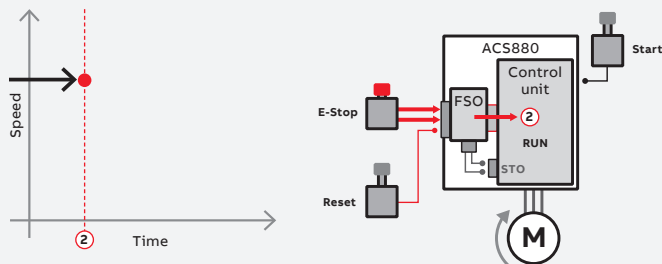

3. Transition and ramp monitoring / time delay elapsing

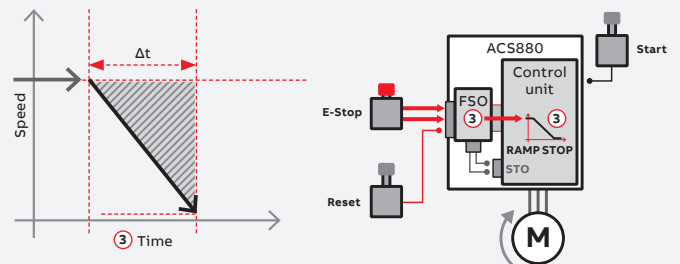

4. Time delay elapsed / zero speed reached / STO is opened

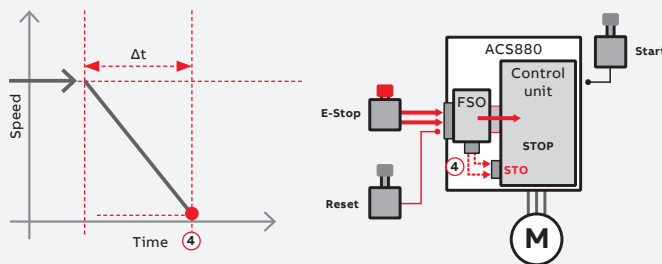

5. Safe state / STO is open

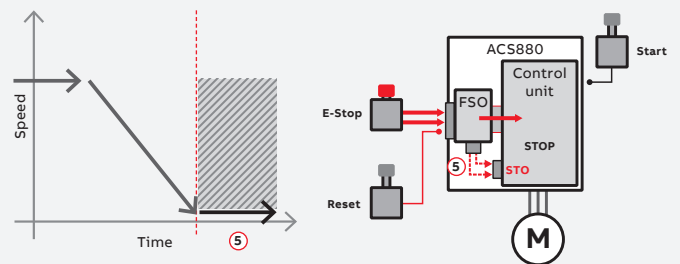

6. Resetting / Acknowledgement / STO is closed

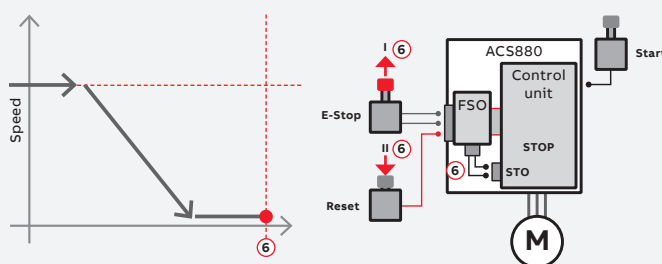

7. Start – return to normal operation

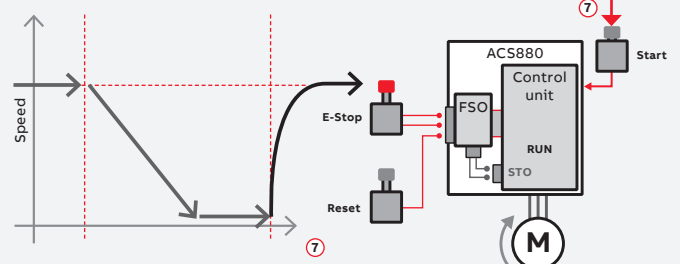

For explosive atmospheres

ATEX certified

What is a potentially explosive atmosphere and where can it be?

Explosive atmospheres occur when flammable gases, mist, vapors or dust are mixed with air, which creates a risk of explosion. A potentially explosive area is defined as a location where there is a risk of flammable mixes. These atmospheres can be found throughout industries, from **chemical, pharmaceutical and food**, to **power and wood processing**. The electrical equipment that is installed in such locations must be designed and tested to endure these conditions and guarantee a safe function.



ATEX
 ATmosphères
 EXplosibles

What does ATEX mean?

The term ATEX comes from the French words "ATmosphères EXplosibles", and it is a combination of two EU directives: the Worker Protection Directive 1999/92/EC and the Product Directive 2014/34/ EU.

The ATEX Directives are designed to protect employees, the public and the environment from accidents owing to explosive atmospheres.

ATEX provides similar guidelines to the IECEx System, with a few exceptions, and with certification of protective devices (e.g. drive-integrated safety functions).



How to ensure a safe operation?

With ABB's ATEX-certified offering and services, safe operation can be ensured.

Motors are directly connected to the machines in the potentially explosive atmosphere, and certain issues need to be considered when selecting a motor together with a drive. These atmospheres have a defined zone classification, and the zone defines the minimum requirements (category) the motors must comply with. The category defines the permitted motor protection types.

Potentially explosive atmosphere zones

Within industries, all potentially explosive atmospheres are required to have an area classification called Zones. Globally, a Zone system is used to classify potentially explosive areas. The Worker Protection Directive 1999/92/EC and the EU standards IEC 60079-10-x, EN 60079-10-x define these zones. In all cases, the owner of the site where the potentially explosive atmosphere exists has the responsibility to define the zones according to the requirements.

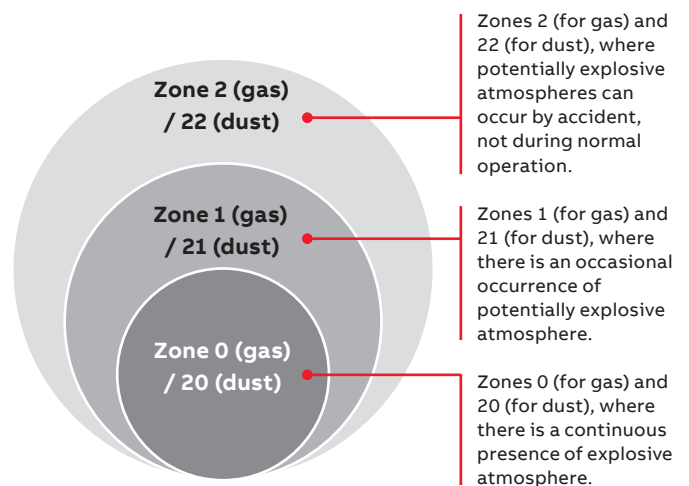

ABB's offering for potentially explosive atmospheres

ABB's ATEX certified offering fulfills the high standards of the ATEX product directive. ABB's tested drive and motor combinations are safe and cost-effective solutions for industries with potentially explosive atmosphere zones. With ABB's ATEX certified modules, safe functions can be guaranteed between non-tested motors and drives. ABB offers full guidance and support to choose the right motors and drives for applications in explosive atmospheres.

Tested packages



Motor and drive combinations are **tested and certified in ABB's test center**. By using an ABB motor together with an ABB drive as a package, you can enjoy the benefits of efficient, high-performance motors with optimal speed and control accuracy – without compromising safety.

With the ABB ATEX certified motor and drive package the ATEX certified temperature protection modules are not obligatory, the tested combinations fulfill the IEC/ATEX standards and ensure a safe performance.

- No additional testing and certification are needed
- No ATEX thermistor protection modules are needed
- Safe and cost effective solution for industries in potentially explosive atmospheres

Safe temperature monitoring



The ATEX thermistor protection modules, CPTC-02 and FPTC-02, can be integrated into the drive if the motor is operating in a potentially explosive environment.

The purpose of the safety function is to disconnect the motor from the power supply before the motor overheats and causes a risk of explosion in an ATEX environment. ATEX classification of the modules is Ex II (2) GD.

ACS580 and ACS880 drives



By using an ABB motor together with an ABB drive, you can enjoy the benefits of efficient, high-performance motors with optimal speed and control accuracy – without compromising safety. IEC/ATEX , Ex II (2) GD certified, tested packages are available with ABB Motors with **ACS580** and **ACS880** drives.

For non-tested and certified motors and drives (e.g. for use with other manufacturer's motors), ATEX certified temperature protection is an integrated option.

Correct dimensioning

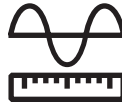

Correct dimensioning is important. **Correctly sized motors and drives reduce motor frame heating and sparks from bearing currents.** They also help to reduce energy use.

Insulation and drive filters

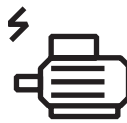

ABB's offering for correct insulation and filters **protects the motor** from voltage phenomena, bearing currents and motor overheating. The insulation and filters must be selected according to voltage and frame size.

Easy drive upgrades



With the drive upgrades below, the ATEX certification stays valid from the old to the new generation models. This means that there is no need for new ATEX certification during the upgrade → you save time and money.

| ATEX certification approved – old generation model | Comparable converter upgrade | ATEX certification stays valid – new generation model |
|--|------------------------------|---|
| ACS600 ^{*)} , ACS800 ^{*)} | → | ACS880 ^{*)} |
| ACS550 | → | ACS580 |

^{*)} DTC (Direct Torque Control)

Global service and support network



ABB's global network of certified service providers are trained and experienced to help you with motors and drives for applications in explosive atmospheres.

The support network ensures that your ABB Declaration of Conformity is retained.

For explosive atmospheres

ATEX certified

To protect against motor overheating, it is essential to understand and keep the motor temperature under control. To ensure safe operation, the motor and drive combination needs to be sized correctly, so it does not exceed the load capacity curve, and the rating plate information must be followed. To protect the motor in a potentially explosive atmosphere, multiple ATEX certified temperature protection function are available according to the drive model, motor and package.

When the ATEX certified protective device is in operation, the engine will be turned off in case of overheating.

The thermistor sensors of the motor are connected to the interface of the ATEX-certified protection module CPTC-02 (ACS580) or FPTC-02 (ACS880) (option code +L537 +Q971), which executes the Safe Motor Temperature protection function (EN/IEC 61800-5-2). Also, different ATEX approved protective relays can be connected directly to the ATEX certified Safe Torque Off (= Safe Disconnection Function, option code +Q971) to guarantee safe temperature control. The traditional way has been to protect the motor from overheating by an external contactor (instead of STO) where a double-rated nominal current is obligatory.

ATEX approved solutions for potentially explosive atmospheres

External temperature protection

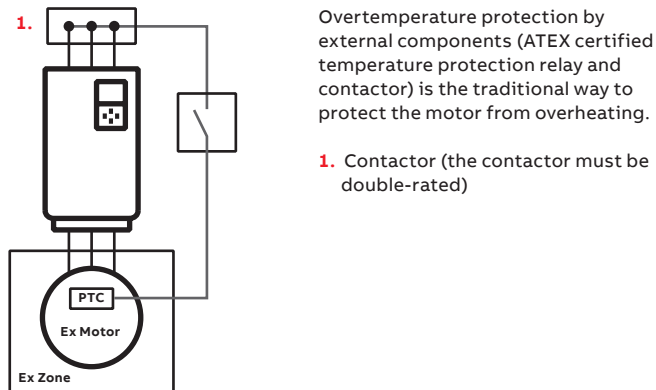

ABB's ATEX certified package^{*)}

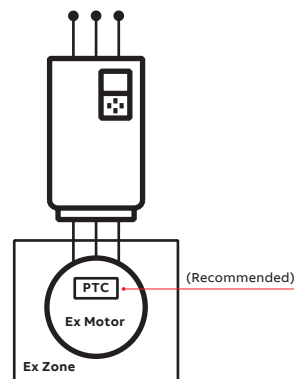

ABB's ATEX thermistor protection modules
CPTC-02 and FPTC-02

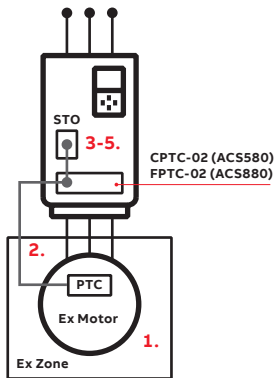

- With option +L537 +Q971 (ACS580 and ACS880):
1. Motor temperature rises above the PTC sensor limit temperature.
 2. The sensor resistance increases very sharply and indicates overheating to the ATEX certified module.
 3. The module switches the STO (safe torque off) circuit off, which activates the STO function.
 4. The STO function disables the control voltage in the power semiconductors of the drive output stage.
 5. The drive is prevented from generating the required torque to rotate the motor.

► **The safe state is guaranteed**

Note:

The CPTC-02 and FPTC-02 (ACS880) module can be managed as a loose option and can also be retrofitted to the drive; in this case, to be compliant with regulations, the customer must ensure the following requirements:

- that the serial number of the drive/inverter module starts with 1, 4, 8, M, Y (CPTC-02) or 1, 8 (FPTC-02)
- that the drive and option serial number is paired in a DIB (Drive Installed Base) portal
- that the included ATEX label for the SMT (Safe Motor Temperature) function is attached to the drive/inverter module to ensure the ATEX compliance of the safety circuit
- that the option module is installed in an option slot of the drive control unit and the applicable drive parameters are set
- that the PTC temperature sensors of the motor are connected to the PTC inputs of the option module.

* For further information please contact local ABB

ABB's ATEX certified STO module option for
ACS880-01, -04, -04XT, -04F, -04FXT

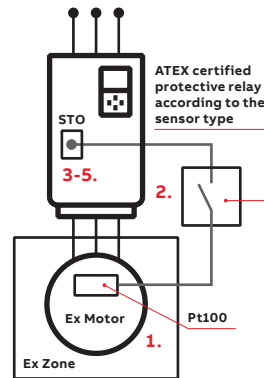

With +Q971 option an external ATEX certified protective relay must be installed. The relay must be chosen according to the sensor type. The most common sensor types are PTC and Pt100, but other sensors can also be used.

1. Motor temperature rises above the Pt100 sensor limit temperature.
2. the sensor resistance increases and indicates overheating to the ATEX certified protective relay.
3. The relay switches the STO (safe torque off) circuit off, which activates the STO function.
4. The STO function disables the control voltage in the power semiconductors of the drive output stage.
5. The drive is prevented from generating the required torque to rotate the motor.

► **The safe state is guaranteed.**

ABB's ATEX certified cabinet option for ACS880-07

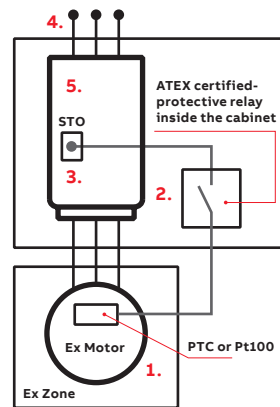

The +L513 (for PTC) and +L514 (for Pt100) options are used for cabinet-built drives (ACS880-07) with an external ATEX certified protective relay that is installed inside the cabinet. (The ATEX certified FPTC-02 module is also an option for ACS880-07, alternative to +L513)

1. Motor temperature rises above the PTC/Pt100 sensor limit temperature.
2. The sensor resistance increases and indicates overheating to the ATEX certified protective relay.
3. The relay switches the STO (safe torque off) circuit off, which activates the STO function.
4. The STO function disables the control voltage in the power semiconductors of the drive output stage.
5. The drive is prevented from generating the required torque to rotate the motor.

► **The safe state is guaranteed.**

Module selection table

| Drive type | ACS580-01 | ACS580-04 | ACS580-07 | ACS880-01 | ACS880-04 | ACS880-04XT | ACS880-04F | ACS880-04FXT | ACS880-07 | ACS880-11/31 | ACS880-14/34 | ACS880-17/37 |
|--|-----------------------|-----------------------|-----------------------|-----------------------|-----------------------|-----------------------|-----------------------|-----------------------|--|-----------------------|-----------------------|--|
| Power range (kW) | 0.75-250 | 250-500 | 75-500 | 0.75-250 | 250-2200 | 560-1200 | 250-710 | 560-1200 | 45-2800 | 2.2-110 | 110-400 | 45-400 |
| Voltage (V) | 380-480 | 380-480 | 380-480 | 208-690 | 380-690 | 380-690 | 380-690 | 380-690 | 380-690 | 380-500 | 380-690 | 380-690 |
| ATEX certified STO | - | - | - | +Q971 ¹⁾ | +Q971 ¹⁾ | +Q971 ¹⁾ | +Q971 ¹⁾ | +Q971 ¹⁾ | +Q971 ¹⁾ | +Q971 ¹⁾ | +Q971 ¹⁾ | +Q971 ¹⁾ |
| ATEX approved motor and drive package | • | • | • | • | • | • | • | • | • | • | • | • |
| ATEX certified protective functions (ATEX thermistor approved) | +L537 +Q971 (CPTC-02) | +L537 +Q971 (CPTC-02) | +L537 +Q971 (CPTC-02) | +L537 +Q971 (FPTC-02) | +L537 +Q971 (FPTC-02) | +L537 +Q971 (FPTC-02) | +L537 +Q971 (FPTC-02) | +L537 +Q971 (FPTC-02) | +L513 (PTC) ²⁾ / +L514 (Pt100) ²⁾ / +L537 (FPTC-02) +Q971 | +L537 +Q971 (FPTC-02) | +L537 +Q971 (FPTC-02) | +L513 (PTC) ²⁾ / +L514 (Pt100) ²⁾ / +L537 (FPTC-02) +Q971 |

¹⁾ ATEX certified protective relay is obligatory and should be chosen according to the sensor type.

²⁾ Codes +L513 (for PTC) and +L514 (for Pt100) includes ATEX approved protective relays.

Application control programs

Optimal use of application

Our application control programs have been developed for the ACS880 drives by working closely with our customers over many years. This has resulted in application programs that include the lessons learned from many customers, and that are designed to give you the flexibility to adapt the programs to your specific needs. These programs enhance application usability and lower energy consumption.

They increase safe operation of the applications and reduce the need for a PLC. Other benefits include protection of



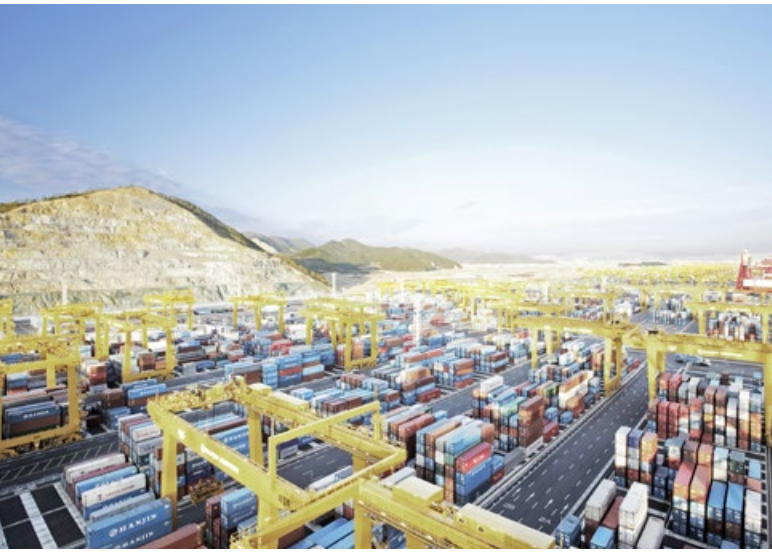

machinery and optimization of application productivity. The programs also optimize time usage and lower operational costs. The ACS880 industrial drive application control programs come with adaptive programming features. This makes fine-tuning of the ready-made application control program functionalities easy. Additionally, we understand that you may need to use different configurations in your process. That's why each of our control programs comes with the ability to configure up to four different configurations.

Application control programs for ACS880

| Application | Features | +Codes |
|---|--|--------|
| Winder control program  | The winder control program ensures optimal winding/unwinding of a roll of web material. The winder program estimates the roll diameter or alternatively use the measured value to keep the web speed optimal. Based on feedback from the dancer or load cell tension measurement, the tension of the web is kept by adjusting the used speed or torque. The result is a straightforward, cost-effective solution for web handling. | +N5000 |
| Crane control program  | The crane control program is designed for use with industrial, harbor, tower and marine deck cranes. Movements in hoist, travel & trolley motions can be controlled in the software. The program comes with integrated mechanical brake control, stand-alone and master-follower functionality, and the capability to synchronize control of multiple motors. Antisway control, either open loop as standard function or closed loop as additional equipment is supported. | +N5050 |
| Tower crane control program  | Designed for tower cranes and includes control for all movements, like hoist, trolley, slew and luffing booms. In addition to the crane control program, the tower crane control program incorporates the slew control support. Tower cranes with high towers and long jibs have a flexible mechanical construction that acts like a spring and causes oscillations. The slew control function in the control program accelerates and decelerates the tower rotation smoothly and minimizes the swinging of loads at start and stop. | +N5650 |
| Winch control program  | The winch control program is a marine application designed for electrically driven deck machinery winches. It supports anchor and mooring control applications. The ability to match speeds for safety is available for systems with an encoder or sensor to measure the chain length. | +N5100 |
| Centrifuge control program  | The centrifuge control program can be used to control conventional centrifuges or decanter centrifuges. With conventional centrifuges the program uses specified speed pattern to efficiently separate solids from liquids. The program provides effective load compensation and accurate speed and torque control without the need for encoder feedback. With decanter centrifuges the process speed and product consistency can be determined by speed difference of the scroll and bowl. | +N5150 |
| PCP control program  | The PCP (progressive cavity pump) control program is designed to optimize oil pumping productivity while protecting pumping equipment. The program does not require speed feedback and reduces pump system stress through various start-up ramp options to limit motor torque and backspin control functionality for safe shutdown. | +N5200 |



Application control programs for ACS880

| Application | Features | +Codes |
|--|--|--------|
| ESP control program  | <p>The ESP (electrical submersible pump) control program is designed for reliable control of ESP applications, which normally consist of a VSD, sine filter, step-up transformer, long cables and medium voltage motor. The control program has plenty of powerful starting modes that improve the motor control near zero frequency up to the operational frequency. One of these functions is rocking start function, which helps to clean the pump from solids. Backspin speed observer is meant to prevent a new start if flying start is not desired. Protective functions can help in situations like gas occurrence, to get rid of the presence of gas, which can cause overheating of the motor. Energy optimizer and U/f curve settings made by the user can reduce the energy consumption of the pumping system.</p> | +N5600 |
| Rod pump control program  | <p>The rod pump control program is designed to optimize oil pumping productivity while protecting pumping equipment. The pump speed can be automatically adjusted based on the varying inflow rate. In this way, the need to stop the pump is minimized, mechanical stress is reduced, and production is optimized. The user can improve the pump efficiency by setting the speed change for upstroke and downstroke. A variety of protection functions are available, e.g. rod string floatation, thermal, pressure and torque limit protections.</p> | +N5250 |
| Test bench control program  | <p>The ACS880 test bench control program together with motors are used to simulate real-life conditions as closely as possible for testing a variety of components and assemblies during all stages of product development and manufacturing.</p> | +N5300 |
| Override control program  | <p>The override control program is used in critical applications, such as tunnel fans. In emergency situations, the program disables most drive/motor protections in order to continue to run the fans until physical failure. Safety features such as safe torque off are always active.</p> | +N5450 |
| Spinning control program  | <p>The spinning control program is designed to run the spinning bobbins in ring frame textile machines. To achieve the best possible form for the doff, the spinning sequence should be ideal for a traverse of the yarn. This is done by giving pre-set values for speed based on the elapsed time or length. The program consists of 4 separate patterns with 16 steps, which can be pre-set by parameters. The modes for each pattern are: Speed Time Patterns (STP), Speed Length Pattern [m] and Speed Length Pattern [%].</p> | +N5500 |

Fieldbus and Industrial Ethernet solutions

Fast and reliable communication

A wide variety of fieldbus systems are available on the market and all major fieldbus protocols are supported by ABB drives, giving you the required flexibility, compatibility and security. So, no matter what preference you may have for communication networks and automation systems, we offer the correct solution to satisfy the specifications.

ABB drives ensure connectivity to automation systems thanks to embedded Protocols and a wide range of **F-series fieldbus interface modules**, giving you a simplified interface to control and manage all ABB drives in low to medium voltage ranges.

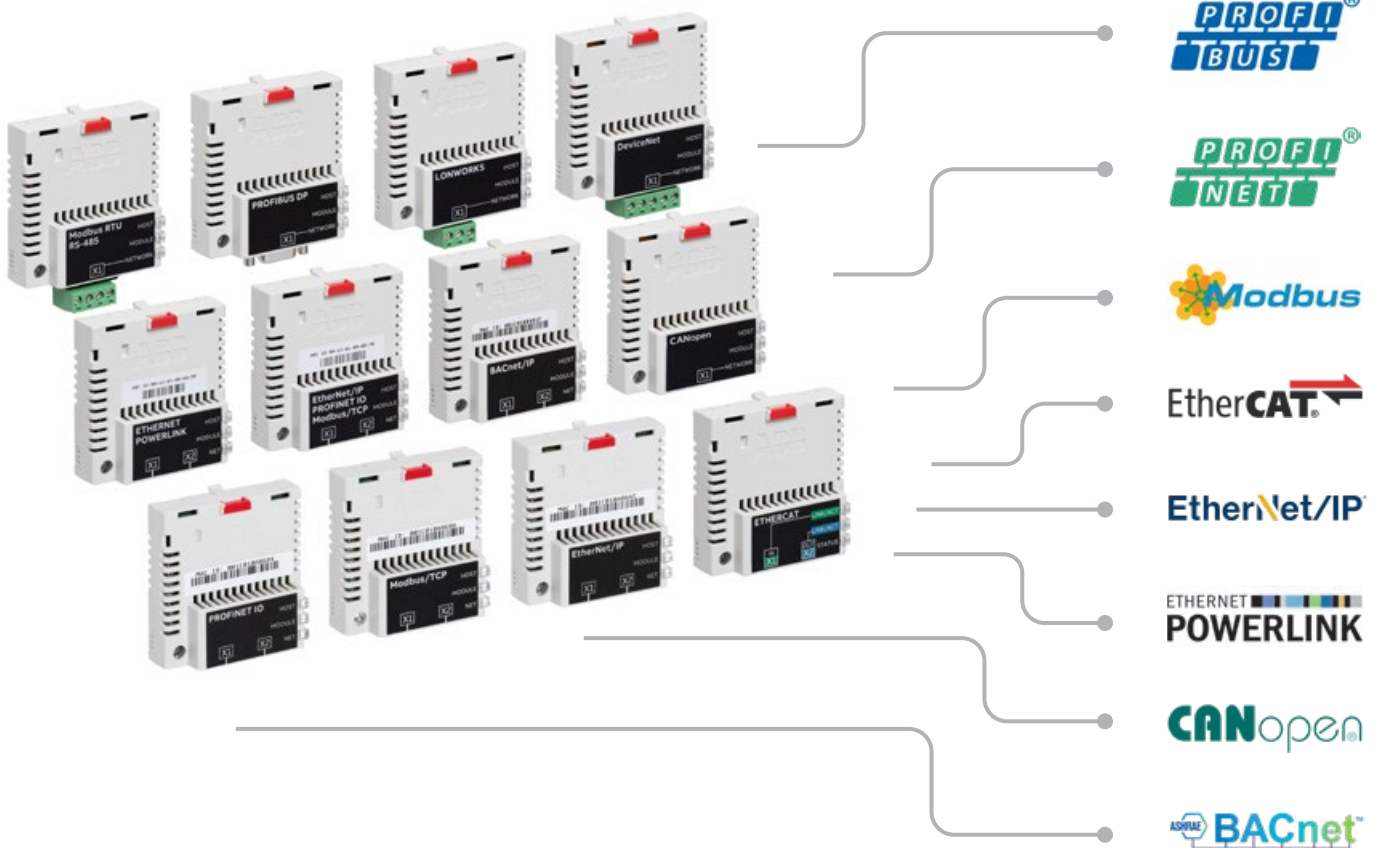

m

Fieldbus adapter module, embedded in all drives

| Fieldbus protocol | Features | Connector type | +Code |
|---|---|----------------|-----------------|
|  | • The interface module acts as a Modbus/RTU server with support for ABB drives profiles | Screw terminal | As standard *) |
| | • Common read/write single and multiple register function codes are supported | Screw terminal | +K458 (FSCA-01) |

*) Modbus RTU as standard only in ACS380 standard variant (ACS380-04xS), for configurable variant (ACS380-04xC) multiple fieldbus options.

The F-series fieldbus adapter modules

| Fieldbus protocols | Features | Connector type | +Code |
|---|--|---------------------------|------------------------------------|
|  | • The interface module acts as an EtherNet/IP™ server with support for ODVA AC/DC drive and ABB drive profiles | 2 x RJ45 | +K490 (FEIP-21) |
| | • Supports both explicit messaging where each attribute of a class is set individually, and implicit messaging using input and output instances | | |
| | • Support device-level ring (DLR) | | |
| | • Has 2 RJ45 connections with an integrated switch | | |
| | • Has Add-On Instructions available | | |
|  | • PROFINET® IO is an open standard for Industrial Ethernet | 2 x RJ45 | +K492 (FPNO-21) |
| | • Used from process automation to motion control, as well as for functional-safety solutions | | |
| | • Supports PROFIdrive and ABB drive profiles | | |
| | • Has 2 RJ45 connections with an integrated switch | | |
| | • Supports ring topology with Media Redundancy Protocol (MRP) | | |
|  | • EtherCAT® is a real-time Ethernet master/slave fieldbus system | 2 x RJ45 | +K469 (FECA-01) |
| | • The EtherCAT slave devices read the data addressed to them while the telegram passes through the device enabling fast real-time communication | | |
| | • The telegrams are only delayed by a few nanoseconds | | |
| | • Supports CiA 402 and ABB drives profiles | | |
| | • Supports PROFIsafe with optional FSO-12/21 for ACS880 and with optional FSPS-21 for ACS380, ACS580 and ACS880 | | |
|  | • CANopen® is a popular industrial communication network originally designed for motion-oriented machine control networks, such as handling systems | Screw terminal D-SUB 9 | +K495 (BCAN-11) +K457 (FCAN-01) |
| | • Supports both cyclic and acyclic event driven communication. This makes it possible to reduce the bus load to a minimum and maintain short reaction times. | | |
| | • Supports CiA 402 and ABB drive profiles | | |
|  | • Ethernet POWERLINK is a real-time protocol for standard Ethernet | 2 x RJ45 | +K470 (FEPL-02) |
| | • The protocol guarantees transfer of time-critical data in very short cycles with configurable response time | | |
| | • Supports CiA 402 and ABB drives profiles | | |
|  | • ControlNet™ is an open control network that meets the demands of real-time, high-throughput applications | 2 x 8P8C | +K462 (FCNA-01) |
| | • Supports controller-to-controller interlocking and real-time control of I/O, drives and valves | | |
| | • Provides control networking in discrete and process applications including high-availability | | |
| | • Supports ODVA AC/DC Drive and ABB drives profiles | | |
| | • Has add-On Instructions available | | |
|  | • DeviceNet™ offers robust, efficient data handling since it is based on a Produce/Consume model | Screw terminal | +K451 (FDNA-01) |
| | • Uses CAN (Controller Area Network) as the backbone technology and defines an application layer to cover a range of device profiles | | |
| | • Supports ODVA AC/DC drive and ABB drives profiles | | |
|  | • The interface module acts as a Modbus® TCP server with support for ABB drive profiles | 2 x RJ45 | +K491 (FMBT-21) |
| | • Common read/write single- and multiple register function codes are supported | | |
| | • Has 2 RJ45 connections with an integrated switch | | |
|  | • PROFIBUS® DP is the most widely used industrial network | D-SUB 9 | +K454 (FPBA-01) |
| | • ABB drives support PROFIBUS DP-V0 and DP-V1 | | |
| | • Supports PROFIdrive and ABB drives profiles | | |

Control panels

A variety of different control panels are available for ABB low voltage AC drives. Some of the drives come with a control panel as standard, and in some cases, a panel can be ordered as an option. All panels can also be bought as spare parts.



01



02



03



04



05



06



07



08



09

01 Assistant control panel, ACS-AP-S
Set up the drive using the assistant control panel. There is no need to know any drive parameters, as the control panel helps you set up the essential settings quickly and get the drive into action without hassle.

02 Bluetooth control panel, ACS-AP-W
Bluetooth panel enables connection e.g. with the Drivetune mobile app. The app is available for free on Google Play and the iOS App store. Together with the Drivetune app, Bluetooth panel users can e.g. commission and monitor the drive wirelessly.

03 Control panel mounting platform, DPMP-01
This mounting platform is for flush mountings. The panel mounting platform does not include the control panel. When using with ACS480 or ACS580, panel bus adapter is required.

04 Basic control panel, ACS-BP-S
The icon-based control panel supports users with parameter backup, settings and fault tracking when basic operation is needed.

05 Panel bus adapter CDPI-01 (only for ACS580), CDPI-02 (only for ACS480)
Used as the control panel adapter when mounting the control panel e.g. on the cabinet door. Connects the assistant control panel, basic control panel, or Bluetooth control panel on the cabinet door to the drive via an RJ-45 cable.

06 ACS380 standard control panel
The standard ACS380 control panel has an icon-based interface and supports users with basic operation, settings and fault tracing. For more advanced needs optional assistant control panels or a PC can be used.

07 Industrial control panel, ACS-AP-I
Multilingual, graphical control panel with high resolution display. Makes using the drive very easy and intuitive. The industrial control panel is compatible with all ABB drives, making it simple to use a single panel with different products.

08 Control panel mounting platform, DPMP-02
This mounting platform is for surface mounting. The panel mounting platform does not include the control panel. When using with ACS480 or ACS580, panel bus adapter is required.

09 Door mounting kit, DPMP-EXT (only for ACS580)
The door mounting kit is a ready-made kit of the DPMP-02 and CDPI-01.

10 Control panel mounting kit for outdoor installation DPMP-04/05
Enables control panel outdoor mounting thanks to IP66 protection class, UV resistance and IK07 impact protection rating.



10



Control panel options

| Type | Description | Option code | ACS380 | ACS480 | ACS580 | ACS880 |
|-----------|--|-----------------|--------|--------|--------|--------|
| - | Fixed icon-based panel | - | ● | - | - | - |
| BSPL-01 | Panel bus adapter | 3AXD50000131976 | ●● | - | - | - |
| BPLG-01 | Panel bus termination plug | 3AXD50000128624 | ●● | - | - | - |
| ACS-AP-S | Assistant control panel | 3AUA0000064884 | ●● | ●● | ●● | - |
| | | +J400 | - | ● | ● | - |
| ACS-AP-I | Industrial control panel | 3AUA0000088311 | ●● | ●● | ●● | - |
| | | +J425 | - | ○ | ○ | ○ |
| ACS-AP-W | Bluetooth control panel | 3AXD0000025965 | ●● | ●● | ●● | ●● |
| | | +J429 | - | ○ | ○ | ● |
| ACS-BP-S | Basic control panel | 3AXD0000028828 | ●● | ●● | ●● | - |
| | | +J404 | - | ○ | ○ | - |
| CDPI-01 | Panel bus adapter with 2xRJ-45 connectors | 3AXD50000004419 | - | - | ●● | - |
| CDPI-02 | Panel bus adapter with 2xRJ-45 connectors | 3AXD50000313204 | - | ●● | - | - |
| CDUM-01 | Blank control panel cover (no control panel delivered) | 3AXD50000009843 | - | - | ●● | - |
| | | +J424 | - | - | ○ | - |
| RDUM-01 | Blank control panel cover with 1x RJ-45 connector | 3AXD50000040850 | - | ●● | - | - |
| DPMP-01 | Control panel mounting platform (flush-mounted, CS480 and ACS580 require also panel bus adapter on the drive) | 3AUA0000108878 | ●● | ●● | ●● | ●● |
| DPMP-02 | Control panel mounting platform (surface-mounted, ACS480 and ACS580 require also panel bus adapter on the drive) | 3AXD50000009374 | ●● | ●● | ●● | ●● |
| DPMP-03 | Control panel mounting platform option, only for ACS580-04 modules | 3AXD50000016230 | - | - | ●● | - |
| DPMP-04 | Control panel mounting kit for outdoor installation (surface-mounted, ACS480 and ACS580 require also panel bus adapter on the drive) | 3AXD50000217717 | ●● | ●● | ●● | ●● |
| DPMP-05 | Control panel mounting kit for outdoor installation (surface-mounted, only for ACS580-04 modules) | 3AXD50000240319 | - | - | ●● | - |
| DPMP-EXT | ACS580 control panel door mounting kit for surface mounting. Contains both DPMP-02 and CDPI-01. | 3AXD50000010763 | - | - | ●● | - |
| DPMP-EXT2 | ACS480 control panel door mounting kit for surface mounting. Contains both DPMP-02 and RDUM-01. | 3AXD50000048730 | - | ●● | - | - |

- = As standard
- = Available as a loose item
- = Available as a plus code option

Assistant control panel

The assistant control panel features intuitive use and easy navigation. The high-resolution display enables visual guidance.

Almost anyone can set up and commission the ABB All-compatible drive using available control panels. You do not need to have much know-how on any drive parameters, as the control panel helps you to set up the essential settings quickly and get the drive into action.

Control of multiple drives

One control panel can be connected to several drives simultaneously using the panel network feature. The user can also select the drive to operate in the panel network.



1. With the customizable **Home views**, you can monitor the values that matter most, e.g. speed, torque or motor temperature. Select the signals from a ready-made list or choose user-defined parameters.
2. **Options** are used to set a reference, change the motor direction, select the drive, edit Home view pages, and see the fault and warning status.
3. All functions of the control panel are accessed through the **main menu**. It is possible to organize parameters in different ways and store essential parameters for different configurations for any specialized application needed.
4. The help key provides context-sensitive guidance. Faults or warnings can be resolved quickly since the help key provides troubleshooting instructions.
5. The PC tool can be easily connected to the drive through the **USB connector** on the control panel.
6. Cutting the wire by Bluetooth interface. User can explore in a new world of offerings from mobile Apps and services.

Assistant control panel display



01

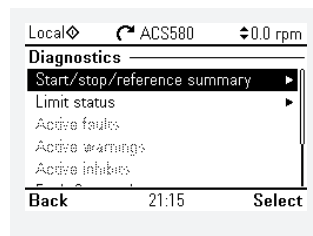

03

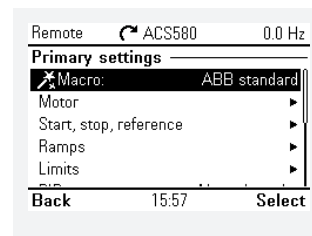

05

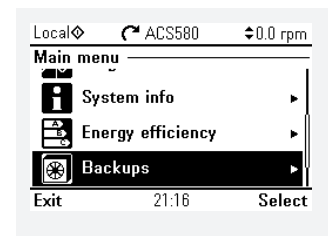

07

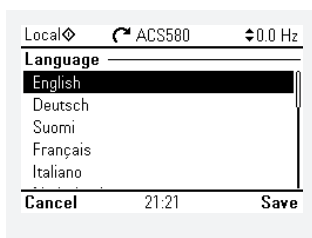

02

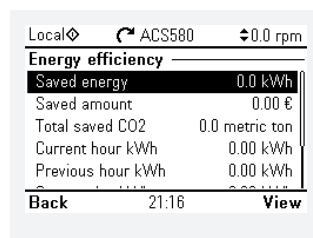

04

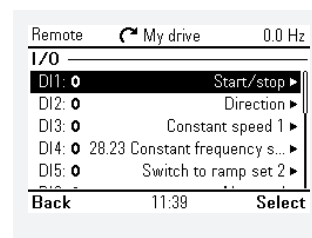

06

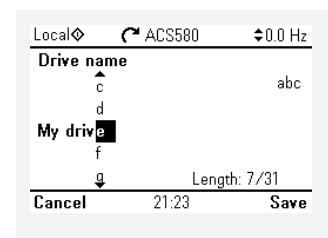

08

01 Help button

- Detailed descriptions related to faults and warnings
- More information about selected parameters

02 Language options

- Access to a selection list that consists of mutually exclusive options such as the language selection list (Access through the main menu)

03 Diagnostics

- Diagnostic information, such as faults and warnings
- Helps to resolve potential problems
- Helps to make sure that the drive setup is functioning correctly

04 Energy efficiency

- View and configure parameters related to energy savings, such as kWh counters

05 Primary settings for ACS580

- Select ready-made macros, such as ABB standard, PFC, Panel PID, 3-wire, perform ID-run, fine-tune settings related to e.g. ramps, limits, PIDs, fieldbuses, reset to defaults

06 I/O Menu

- Access to each terminal name, number and electrical status
- Access to sub-menus that provide further information on the menu item and allow users to make changes to the I/O connections

07 Backups

- Possibility to save parameter settings in the control panel memory and restore parameter settings from a backup to the drive

08 Text editor

- Add information, customize text and label the drive



ABB Ability™ Condition Monitoring for drives



Condition Monitoring gives you fact-based insight into your drives, via KPIs and signal data, to keep your processes moving smoothly.

Remote monitoring of your drives lets you identify irregularities before they become problems. This helps you make proactive decisions, built on real-time information – and saves you money!



Solid fact-based decision making

Get the facts, and the history, to help run your operations better and more safely.



Always stay one step ahead of problems

Recognize early signs of possible failures and assess the risks, before they turn into serious operational issues.



Find the root cause of process issues

Remotely access data from ABB drives built-in sensors to track the cause of problems. Get back to smooth operation quickly with data back-ups.



Remotely analyze and optimize drives

Get critical drive information anywhere anytime – even in difficult to access sites, or when a site visit is impossible.

Tailor your drive monitoring to perfectly fit your needs

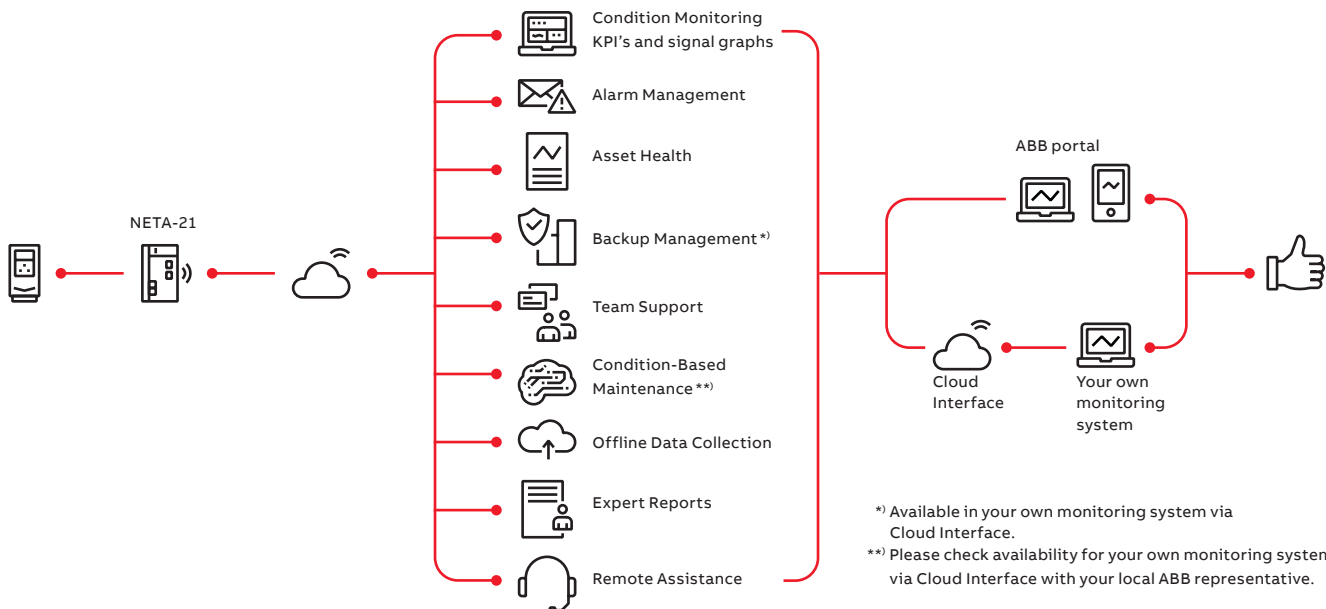

*) Available in your own monitoring system via Cloud Interface.

***) Please check availability for your own monitoring system via Cloud Interface with your local ABB representative.

NETA-21

NETA-21 connects the drive to the cloud via the Internet or local Ethernet network.

- The module comes with a built-in web server and requires no Flash/Java plugins
- In the absence of a customer local area network, it can be connected via a mobile network router (either Ethernet or USB network adapter)
- One module can be connected to several drives at the same time

| NETA-21 | Ordering code | Description |
|--|----------------|-------------------------|
|  | 3AUA0000094517 | 2 x panel bus interface |
| | | max. 9 drives |
| | | 2 x Ethernet interface |
| | | SD memory card |

RMDE reliability monitoring device



The RMDE reliability monitoring device facilitates the installation of the connectivity device (NETA-21) on drives that are already installed.

- The RMDE device can contain two or four NETA modules and can connect up to 18 or even 36 drives
- The cabinet consists of the NETA-21 connectivity devices, a modem and environmental sensors that enable the collection of measured ambient temperature and humidity values
- The cabinet includes a compact IP54 enclosure, making it suitable even for harsh environments

Service delivery process

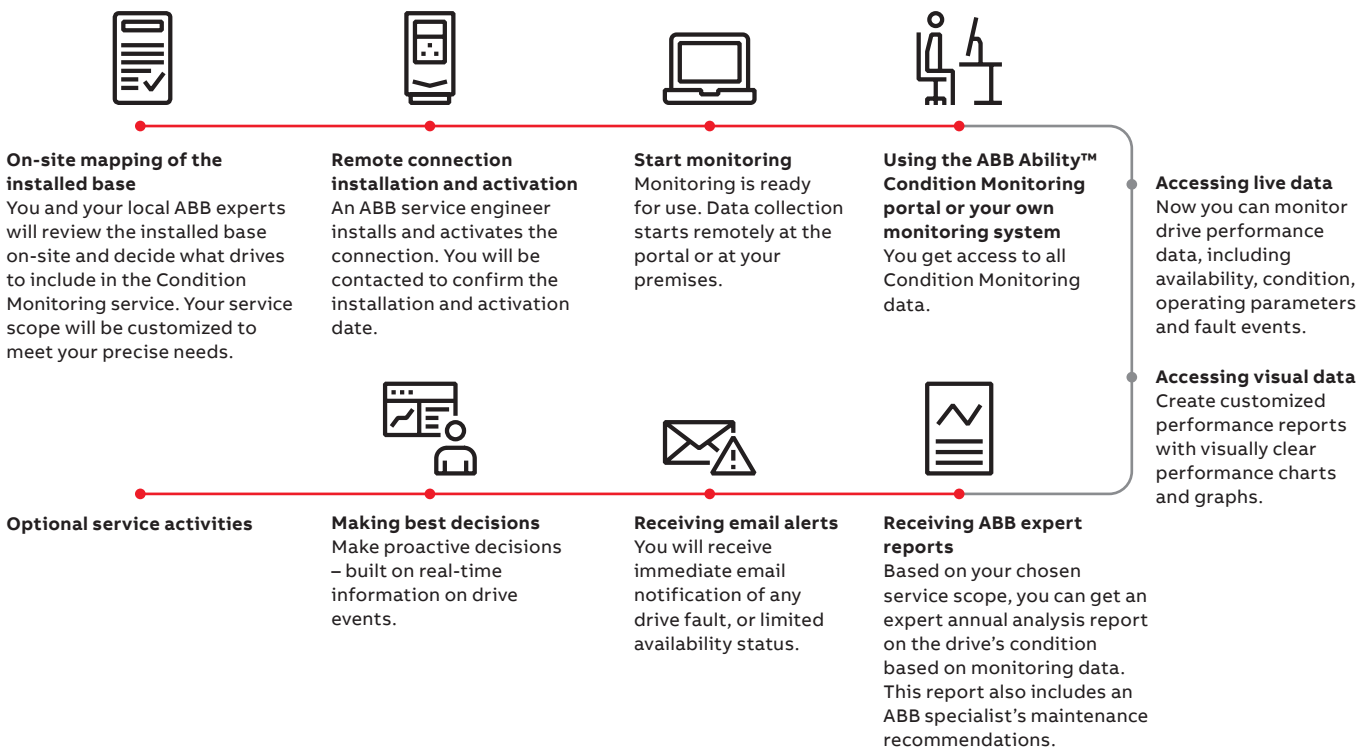

Options, features and benefits to keep your operations running smoothly

ABB Ability™ Condition Monitoring for drives

| Standard package includes | Main features | Benefits |
|---|--|--|
| Condition Monitoring ^{*)} | <ul style="list-style-type: none"> • ABB portal <ul style="list-style-type: none"> • Track drive condition KPIs: availability, ambient environment, reliability and stress • View signal graphs for: speed, torque, current, power, temperature and energy consumption | <ul style="list-style-type: none"> • Monitor drive performance, without the need to send someone to the site • Access signal data history to spot changes and anomalies in drive behavior over time • Overlay data to spot cause-and-effect correlations between different parameters and measurements |
| | Cloud Interface <ul style="list-style-type: none"> • Programmable interface that allows you to transfer the Condition Monitoring data from the ABB Ability™ cloud to your own monitoring systems • Sample application kit (SDK) included, upon request | <ul style="list-style-type: none"> • Enable connectivity from ABB cloud to your cloud or internet enabled local applications, facilitating the integration in your monitoring systems |
| Alarm Management | <ul style="list-style-type: none"> • Configurable alert settings by signal threshold • Configurable alert delivery to defined addresses • Choose which alarms you want email alerts sent for | <ul style="list-style-type: none"> • Get immediate information when condition signals exceed the set limits • Launch your maintenance and repair actions without delays |
| Asset Health | <ul style="list-style-type: none"> • Configurable drive condition Word format reports and fleet comparisons | <ul style="list-style-type: none"> • Generate professional Word format reports to support: <ul style="list-style-type: none"> - Your daily maintenance and repair activities - Yearly maintenance planning and strategic decisions • Get background material to help support your investment decisions and planning |
| Team Support ^{*)} | <ul style="list-style-type: none"> • Remotely view drive signal data loggers, history loggers, error incidents • Add comments, notes and support logs • Support your team from a distance, to raise their skill levels | <ul style="list-style-type: none"> • Access history logs to all information and data collected from the drive, for expert level analysis and fault tracing • Write and view comment logs to keep notes about drive performance, to support given and successful solutions |
| Backup Management ^{**)} | <ul style="list-style-type: none"> • Alerts in case of parameter changes • Parameter back-up features that facilitate drive recovery • Parameter recovery features | <ul style="list-style-type: none"> • Minimize downtime when you have a drive exchange or breakage • Protect against misuse and accidental parameter changes • Eliminate the need for time-consuming fault tracing procedures |

m



—
ABB Ability™ Condition Monitoring for drives

| Additional options | Main features | Benefits |
|---|---|---|
| Powertrain Monitoring | <ul style="list-style-type: none"> This free option lets you combine key information from Condition Monitoring for drives with Smart Sensors for motors and mounted bearings, to get the complete ABB Ability™ Powertrain Monitoring View aggregated KPI graphs and analytics for the complete powertrain | <ul style="list-style-type: none"> Get aggregated information from a variety of sensors and drives, and gain visibility over the condition of your whole powertrain |
| Condition-Based Maintenance ***) | <ul style="list-style-type: none"> Measures operational and environmental stress, to estimate the condition and lifetime of key electric components Ageing status view indicator and clear maintenance timing suggestions Measures condition of DC link capacitors, IGBT and fans | <ul style="list-style-type: none"> Establish maintenance plan based on actual drive usage and conditions Take proactive maintenance actions before failures occur Optimize maintenance costs and scheduling Identify problems in drive usage or changes in operational behavior |
| Offline Data Collection | <ul style="list-style-type: none"> Manual bulk data upload to ABB Ability™ cloud services | <ul style="list-style-type: none"> Move data from devices to cloud, without using online connectivity to the Internet, when strict cyber security criteria are required |
| Expert Reports | <ul style="list-style-type: none"> ABB generated reports, with comments and recommendations from a Drive Expert, including notes based on the drive signal data | <ul style="list-style-type: none"> Get expert information for maintenance and repair planning activities Get professional advice for investment decisions and planning Receive advice and consultation regarding drive use issues – which may be identified through the signal data |
| Remote Assistance | <ul style="list-style-type: none"> Local ABB technical support, connected to drive signal data and condition information | <ul style="list-style-type: none"> Solve your problems quickly – ABB experts can see your drive signal information, analyse it and provide advice for faster resolution Obtain outsourced assistance to save on the need for highly skilled and costly resources on your own team and payroll |

- Self-service, relying entirely on computer analyzed information and automated processes
 - Assisted service, involving ABB experts to analyze information and provide assistance
- *) Available also without cloud connection with ABB Ability™ Condition Monitoring for drives – On-Premises service. The service includes Team Support and access to parameter backup through the user interface. For more information, please contact your local ABB representative.
- **) Available in your own monitoring system via Cloud Interface.
- ***) Please check Cloud Interface availability with your local ABB representative.



ABB Ability™ Digital Powertrain

1 Intelligent powertrain

The powertrain is equipped with sensors and cloud connectivity and can comprise motors, drives, mechanical components including bearings, couplings and gearboxes – and also pumps. You can choose yourself what assets you want to monitor.

2 Turning data into valuable information

Data gathered from drives' inbuilt sensors and loggers together with that collected from ABB Ability™ Smart Sensors fitted to motors, bearings and pumps, can be aggregated, stored and further accessed via the cloud. The ability to gather and analyze this data can reveal information on the status and condition of your equipment, so that you can schedule service activities more effectively.



ABB Ability™ Condition Monitoring service for powertrains optimizes the performance and efficiency of rotating equipment. It enables full transparency on key parameters for drives, motors, mounted bearings and pumps, and can also be used in applications such as compressors, conveyors, mixers and extruder main shafts.

3 Accessing data for analytics

You have access to a monitoring portal to view key operational parameters of individual assets as one unified system. Detailed dashboards give full transparency so that you can take actions that lead to less downtime, extended equipment lifetime, lower costs, safer operations and increased profitability.

4 Gain a digital advantage

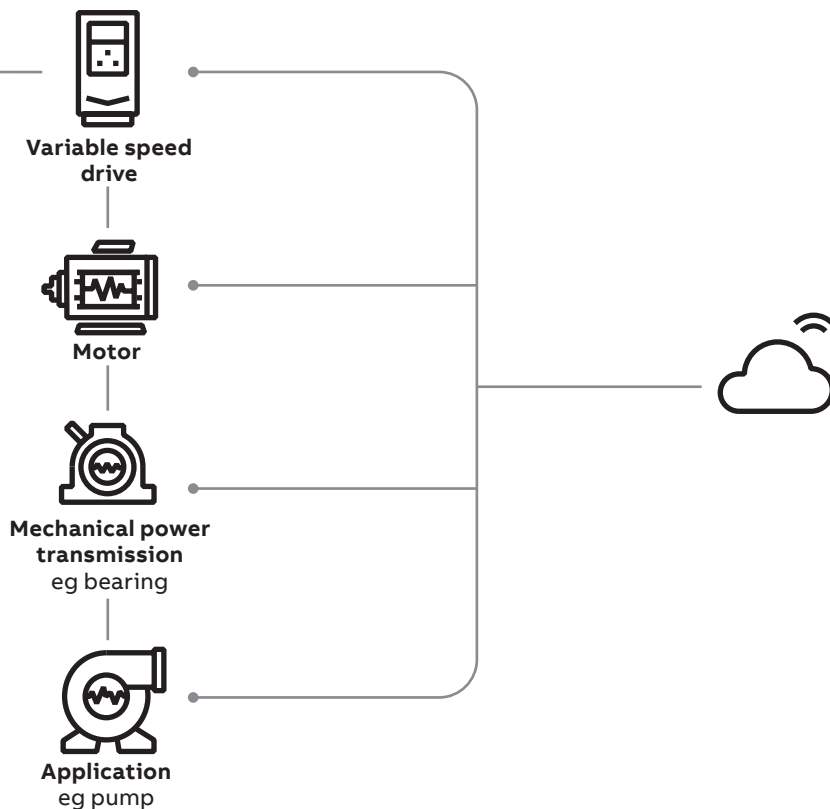
Ensuring that the right person has the right information to at the right time brings:

- Appropriate response to production challenges, minimizing operating costs and wastage of products
- Greater insight into various aspects of your process, thereby improving quality and reducing variations, errors and waste
- Lower risk of production downtime and change of the maintenance from reactive to predictive



Commissioning and programming tools

Giving you simple yet powerful performance enhancements

Your engineering efficiency can be greatly boosted by using our commissioning and programming tools, giving you easy and optimized solutions to design, build, and test your ABB drives or machines. Our range of software tools will both simplify and enhance the use of your assets throughout their life cycle, from the very start. Here are the most essential ones.

Drive Composer

The **Drive Composer PC tool** for Windows offers users fast and harmonized setup, commissioning and monitoring for ABB's all-compatible drives. The tool is connected to the drive's control panel via a USB interface or Ethernet connection. This allows access to full drive parameters for commissioning and configuring of the drives, and also provides online drive monitoring services and easy access to log information for potential problem solving.

Drive Composer is available in two different versions:

- The Entry level version offers basic functionalities, and can be downloaded free of charge from the ABB webpage (<https://new.abb.com/drives/software-tools/drive-composer>)
- The Pro version offers additional advanced functionalities and can be purchased through your ABB sales channels.

Adaptive Programming tool

This software allows you to enhance the existing application control program and precisely fit it to the application's needs. It customizes the drive parameters to control the process in an optimal way, resulting in substantial energy savings and reduced operational costs.

Adaptive Programming is embedded inside the drive and can add some of the PLC's control functionalities, when needed. The Drive Composer PC tool is used to set up Adaptive Programming.

Drive Application Builder

This tool allows you to add an application-specific expertise to your machines. Thanks to the built-in PLC functionality of ACS880 drives, you can combine your own application knowledge with our highly functional AC drives.

The **ABB Drive Application Builder tool** is used for drive application programming helping you to turn a standard drive into an application-specific one.

The tool can be used with the ACS880, DCS880, and DCT880 drives series. It is based on the IEC61131-3 programming standard, which makes it possible to start program development with minimal training and to transfer customized programs to other platforms. Drive-based IEC programming offers functionality like PLCs to better serve your application's requirements but without a need for investing in and installing an external PLC. To enable drive application programming, you need the +N8010 license. Thanks to fewer system components and simpler installation work, drive application programming brings you both cost savings and maximum reliability.

ABB Ability™ Virtual Commissioning for drives

This is our virtual engineering and commissioning solution, allowing machine builders and system integrators to develop and simulate entire industrial processing lines and machines, including ABB drives, without running the hardware. It gives valuable benefits in the phases of designing, commissioning and operating machines, saving time, reducing risks, and increasing engineering productivity.

Virtual drives are commissioned in the same way as the real drives, using the Drive Composer Pro tool. Engineers can start configuring and programming drives well before receiving them from the ABB production line, since the same software tools, like Drive Composer Pro, can be used with both virtual and real drives.

Virtualization allows you to cover the kinematic and physical behavior of the machine and the overriding automation. Virtual drives can also be used with the ABB Robot Studio and ABB Automation Builder programming tools to build more complete virtual machines and processing lines.

Drive Manager for SIMATIC

Drive Manager for SIMATIC is an excellent tool for automation engineers who are setting up SIEMENS PLCs to communicate with ABB drives. Drive Manager is a plug-in device tool that can be easily installed into the STEP 7 and TIA Portal. It utilizes the TCI interface of the SIMATIC PLC to communicate with drives connected to PROFIBUS or PROFINET network.

Drive Manager offers several useful ready-made features that simplify the setup of ABB low voltage drives used in combination with SIMATIC S7 PLCs, including network connection. The tool also offers several other features, like online and offline configuration of drives, monitoring of actual drive values, export and import of the data using drive dedicated PC tools, and saving drive parameter settings within the SIMATIC PLC project.

Software variants and ordering codes

| PC tools | Description | Option codes |
|---------------------------------------|---|-----------------|
| Drive Composer Entry level version | Download free from https://new.abb.com/drives/software-tools/drive-composer | |
| DCPT-01 Drive Composer Pro version | Drive Composer Pro tool – Single user license | 3AUA0000108087 |
| | Drive Composer Pro tool – Max 10 users license | 3AUA0000145150 |
| | Drive Composer Pro tool – Max 20 users license | 3AUA0000145151 |
| Drive application programming | IEC 61131-3 programming License | N8010 |
| DABS-STANDARD | Standard version of the Drive Application Builder for IEC 61131-3 programming | 3AXD50000342389 |
| DABS-STANDARD-MULTIPLE-WS | Standard version of the Drive Application Builder for IEC 61131-3 programming for multiple workstations (max 5) | 3AXD50000342396 |
| DABX-PRODUCTIVITY-ADD-ONS | Software development productivity add-ons for Drive Application Builder, version control and static analysis extensions for improve software engineering productivity | 3AXD50000343027 |
| DM4S-01 Drive Manager for SIMATIC | Add-on tool to SIEMENS engineering tool environment for ABB's common architecture drives. Single user license. | 3AXD50000012272 |
| VD-ENGINEERING | Virtual drive, motor and load simulation, dimensioning and testing consoles, adaptive programming for single | 3AXD50000343102 |
| VD-ENGINEERING-MULTIPLE-WS | Virtual drive, motor and load simulation, dimensioning and testing consoles, adaptive programming for multiple workstations (max 10) | 3AXD50000343119 |
| VD-APPLICATION-PROGRAMMING | Virtual drive, motor and load simulation, dimensioning and testing consoles and application (IEC) programming | 3AXD50000343126 |
| VD-APPLICATION-PROG-MULTIPLE-WS | Virtual drive, motor and load simulation, dimensioning and testing consoles and application (IEC) programming, multiple workstations (max 5) | 3AXD50000343133 |

All software tools can be downloaded from the ABB website: <https://new.abb.com/drives/software-tools>, with a free 30 days trial version.

Mobile tools

Commissioning and managing drives

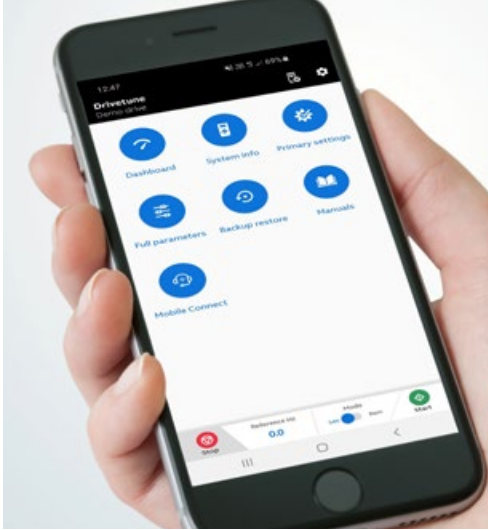

01

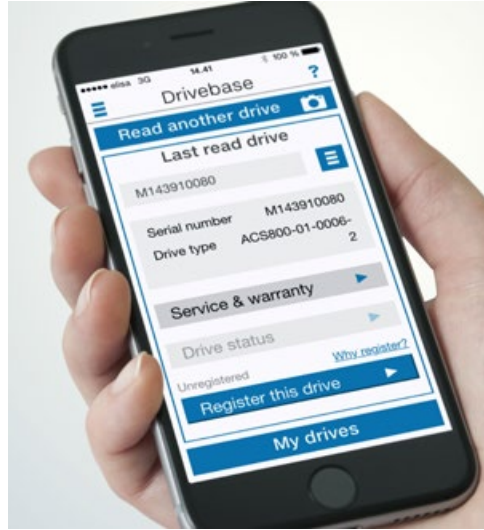

02

Drivetune

Drivetune is a smartphone application which is capable of connecting wirelessly to ABB drives. By using a user-friendly interface, you can more quickly and efficiently start-up and tune your drive and the application it controls. The appealing dashboard intuitively shows the drive status, performance and configuration.

The Drivetune app makes it possible to connect with any services and data available on the Internet in parallel to online drive communication, providing a powerful tool for performing basic start-up and troubleshooting tasks. The wireless Bluetooth connectivity means that users do not need to enter hazardous or difficult-to-reach work areas to access the information necessary to help them commission and tune a drive.

Mobile Connect

ABB Ability™ Mobile Connect for drives is a feature in the Drivetune mobile application for remote support. It is a platform that provides end users with drive support from anywhere. It allows partners to remotely communicate with on-site drive users or service personnel, to help them easily commission and troubleshoot drives.

Chats, sharing images and backups, viewing parameters online and sending support packages are all possible, making the partner's technical support process quick and efficient.

Mobile Connect offers two different interfaces based on the user profile: a web portal for the partner's team of experts, and a Drivetune mobile app for drive users. Partners manage cases in the web portal and end users access them via a unique case ID with their mobile phone. Mobile Connect web portal access for partners will be sold via Ability Marketplace™ with a renewable subscription-based licensing agreement.

Drivebase

Drivebase is a smartphone application which allows easy access to product manuals and search function for ABB contacts. The app also facilitates a capability to report service actions and provides users with service recommendations for their drives installed base.

An app user can scan a dynamic QR code generated by a drive on its control panel and receive information for troubleshooting should problems occur. Drives can also be registered to get an additional warranty.

01 Drivetune

- Easy start-up of a drive
- Basic troubleshooting capabilities
- Access to product technical information
- Improved user experience
- Mobile Connect enables access to onsite technical support

02 Drivebase

- Get online product manuals
- Find your closest service provider
- Store drive information on your device
- Get service recommendations
- Record service actions
- Troubleshoot your drives
- Register your drive

Heat, noise and airflow

| ACS380 | | | | | | | | |
|---|------------|---|-----------------------------------|-----------------------------------|---------------------------------------|---------------------------------|-----------------------|--|
| Type designation | Frame size | Heat dissipation | | | | Air flow (m ³ /h) | Max. Noise (dB(A)) | |
| | | Main circuit at rated I_{1N} and I_{2N} (W) | Control circuit minimum (W) | Control circuit maximum (W) | Main control boards maximum (W) | | | |
| 1-phase $U_N = 200...240$ V | | | | | | | | |
| ACS380-04xx-02A4-1 | R0 | 32 | 17 | 20 | 52 | –*) | <30 | |
| ACS380-04xx-03A7-1 | R0 | 46 | 17 | 20 | 66 | –*) | <30 | |
| ACS380-04xx-04A8-1 | R1 | 59 | 24 | 25 | 84 | 57 | 63 | |
| ACS380-04xx-06A9-1 | R1 | 85 | 24 | 25 | 109 | 57 | 63 | |
| ACS380-04xx-07A8-1 | R1 | 95 | 24 | 25 | 120 | 57 | 63 | |
| ACS380-04xx-09A8-1 | R2 | 115 | 24 | 25 | 140 | 63 | 59 | |
| ACS380-04xx-12A2-1 | R2 | 145 | 24 | 25 | 170 | 63 | 59 | |
| 3-phase $U_N = 200...240$ V | | | | | | | | |
| ACS380-04xx-02A4-2 | R1 | 19 | 9 | 20 | 39 | 57 | 63 | |
| ACS380-04xx-03A7-2 | R1 | 26 | 9 | 20 | 46 | 57 | 63 | |
| ACS380-04xx-04A8-2 | R1 | 35 | 9 | 20 | 55 | 57 | 63 | |
| ACS380-04xx-06A9-2 | R1 | 42 | 9 | 20 | 62 | 57 | 63 | |
| ACS380-04xx-07A8-2 | R1 | 50 | 9 | 20 | 70 | 57 | 63 | |
| ACS380-04xx-09A8-2 | R1 | 68 | 9 | 20 | 88 | 57 | 63 | |
| ACS380-04xx-12A2-2 | R2 | 87 | 9 | 20 | 107 | 63 | 59 | |
| ACS380-04xx-17A5-2 | R3 | 116 | 11 | 22 | 138 | 128 | 66 | |
| ACS380-04xx-25A0-2 | R3 | 160 | 11 | 22 | 182 | 128 | 66 | |
| ACS380-04xx-032A-2 | R4 | 218 | 18 | 30 | 247 | 150 | 69 | |
| ACS380-04xx-048A-2 | R4 | 319 | 18 | 30 | 349 | 150 | 69 | |
| ACS380-04xx-055A-2 | R4 | 435 | 18 | 30 | 465 | 150 | 69 | |
| 3-phase $U_N = 380...480$ V | | | | | | | | |
| ACS380-04xx-01A8-4 | R0 | 26 | 17 | 20 | 46 | –*) | <30 | |
| ACS380-04xx-02A6-4 | R1 | 35 | 24 | 25 | 60 | 57 | 63 | |
| ACS380-04xx-03A3-4 | R1 | 42 | 24 | 25 | 67 | 57 | 63 | |
| ACS380-04xx-04A0-4 | R1 | 50 | 24 | 25 | 75 | 57 | 63 | |
| ACS380-04xx-05A6-4 | R1 | 68 | 24 | 25 | 93 | 57 | 63 | |
| ACS380-04xx-07A2-4 | R1 | 88 | 24 | 25 | 115 | 57 | 63 | |
| ACS380-04xx-09A4-4 | R1 | 115 | 24 | 25 | 139 | 57 | 63 | |
| ACS380-04xx-12A6-4 | R2 | 158 | 24 | 25 | 183 | 63 | 59 | |
| ACS380-04xx-17A0-4 | R3 | 208 | 24 | 25 | 232 | 128 | 66 | |
| ACS380-04xx-25A0-4 | R3 | 322 | 24 | 25 | 346 | 128 | 66 | |
| ACS380-04xx-032A-4 | R4 | 435 | 24 | 25 | 460 | 460 | 69 | |
| ACS380-04xx-038A-4 | R4 | 537 | 24 | 25 | 561 | 561 | 69 | |
| ACS380-04xx-045A-4 | R4 | 638 | 24 | 25 | 663 | 663 | 69 | |
| ACS380-04xx-050A-4 | R4 | 709 | 24 | 25 | 734 | 661 | 69 | |

*) Frame size R0 with free convection cooling

| ACS480-04 | | | | | | | | | |
|-----------------------|------------|---|-----------------------------------|-----------------------------------|---------------------------------------|---------------------|----------------------------|-----------------------|--|
| 3-phase $U_N = 400$ V | | | | | | | | | |
| Type designation | Frame size | Heat dissipation | | | | Air flow | | Max. Noise (dB(A)) | |
| | | Main circuit at rated I_{1N} and I_{2N} (W) | Control circuit minimum (W) | Control circuit maximum (W) | Main control boards maximum (W) | (m ³ /h) | (ft ³ / min) | | |
| ACS480-04-02A7-4 | R1 | 35 | 9 | 20 | 55 | 57 | 33 | 63 | |
| ACS480-04-03A4-4 | R1 | 42 | 9 | 20 | 62 | 57 | 33 | 63 | |
| ACS480-04-04A1-4 | R1 | 50 | 9 | 20 | 70 | 57 | 33 | 63 | |
| ACS480-04-05A7-4 | R1 | 68 | 9 | 20 | 88 | 57 | 33 | 63 | |
| ACS480-04-07A3-4 | R1 | 88 | 9 | 20 | 108 | 57 | 33 | 63 | |
| ACS480-04-09A5-4 | R1 | 115 | 9 | 20 | 135 | 57 | 33 | 63 | |
| ACS480-04-12A7-4 | R2 | 158 | 9 | 20 | 178 | 63 | 37 | 59 | |
| ACS480-04-018A-4 | R3 | 208 | 11 | 22 | 230 | 128 | 75 | 66 | |
| ACS480-04-026A-4 | R3 | 322 | 11 | 22 | 344 | 128 | 75 | 66 | |
| ACS480-04-033A-4 | R4 | 435 | 18 | 30 | 465 | 150 | 88 | 69 | |
| ACS480-04-039A-4 | R4 | 537 | 18 | 30 | 566 | 150 | 88 | 69 | |
| ACS480-04-046A-4 | R4 | 638 | 18 | 30 | 668 | 150 | 88 | 69 | |
| ACS480-04-050A-4 | R4 | 638 | 18 | 30 | 668 | 150 | 88 | 69 | |

ACS580-01**3-phase $U_N = 400\text{ V}$**

| Type designation | Frame size | Heat dissipation | | | | Air flow (IP21/42) | | Max. Noise (dB(A)) |
|------------------|------------|---|-----------------------------------|-----------------------------------|---------------------------------------|---------------------|----------------------------|-----------------------|
| | | Main circuit at rated I_{1N} and I_{2N} (W) | Control circuit minimum (W) | Control circuit maximum (W) | Main control boards maximum (W) | (m ³ /h) | (ft ³ / min) | |
| ACS580-01-02A7-4 | R1 | 20 | 3.5 | 25 | 45 | 43 | 25 | 59 |
| ACS580-01-03A4-4 | R1 | 30 | 3.5 | 25 | 55 | 43 | 25 | 59 |
| ACS580-01-04A1-4 | R1 | 41 | 3.5 | 25 | 66 | 43 | 25 | 59 |
| ACS580-01-05A7-4 | R1 | 59 | 3.5 | 25 | 84 | 43 | 25 | 59 |
| ACS580-01-07A2-4 | R1 | 81 | 3.5 | 25 | 106 | 43 | 25 | 59 |
| ACS580-01-09A5-4 | R1 | 108 | 3.5 | 25 | 133 | 43 | 25 | 59 |
| ACS580-01-12A7-4 | R1 | 149 | 3.5 | 25 | 174 | 43 | 25 | 59 |
| ACS580-01-018A-4 | R2 | 203 | 3.5 | 25 | 228 | 101 | 59 | 64 |
| ACS580-01-026A-4 | R2 | 297 | 3.5 | 25 | 322 | 101 | 59 | 64 |
| ACS580-01-033A-4 | R3 | 405 | 3.5 | 25 | 430 | 179 | 105 | 76 |
| ACS580-01-039A-4 | R3 | 500 | 3.5 | 25 | 525 | 179 | 105 | 76 |
| ACS580-01-046A-4 | R3 | 594 | 3.5 | 25 | 619 | 179 | 105 | 76 |
| ACS580-01-062A-4 | R4 | 810 | 3.5 | 25 | 835 | 134 | 79 | 69 |
| ACS580-01-073A-4 | R4 | 999 | 3.5 | 25 | 1024 | 134 | 79 | 69 |
| ACS580-01-088A-4 | R5 | 1215 | 3.5 | 25 | 1240 | 139 | 82 | 63 |
| ACS580-01-106A-4 | R5 | 1485 | 3.5 | 25 | 1510 | 139 | 82 | 63 |
| ACS580-01-145A-4 | R6 | 1440 | 4.1 | 36 | 1476 | 435 | 256 | 67 |
| ACS580-01-169A-4 | R7 | 1940 | 4.1 | 36 | 1976 | 450 | 265 | 67 |
| ACS580-01-206A-4 | R7 | 2310 | 4.1 | 36 | 2346 | 450 | 265 | 67 |
| ACS580-01-246A-4 | R8 | 3300 | 4.1 | 36 | 3336 | 550 | 324 | 65 |
| ACS580-01-293A-4 | R8 | 3900 | 4.1 | 36 | 3936 | 550 | 324 | 65 |
| ACS580-01-363A-4 | R9 | 4800 | 4.1 | 36 | 4836 | 1150 | 677 | 68 |
| ACS580-01-430A-4 | R9 | 6000 | 4.1 | 36 | 6036 | 1150 | 677 | 68 |

ACS580-04 **$U_N = 400\text{ V}$**

| Type designation | Frame size | Heat dissipation (W) | Air flow | | Max. Noise (dB(A)) |
|------------------|------------|-------------------------|---------------------|------------------------|-----------------------|
| | | | (m ³ /h) | (ft ³ /min) | |
| ACS580-04-505A-4 | R10 | 5602 | 1200 | 707 | 72 |
| ACS580-04-585A-4 | R10 | 6409 | 1200 | 707 | 72 |
| ACS580-04-650A-4 | R10 | 8122 | 1200 | 707 | 72 |
| ACS580-04-725A-4 | R11 | 8764 | 1200 | 707 | 72 |
| ACS580-04-820A-4 | R11 | 9862 | 1200 | 707 | 72 |
| ACS580-04-880A-4 | R11 | 10578 | 1420 | 836 | 72 |

ACS580-07 **$U_N = 400\text{ V}$**

| Type designation | Frame size | Heat dissipation (W) | Air flow | | Max. Noise (dB(A)) |
|-------------------|------------|-------------------------|---------------------|------------------------|-----------------------|
| | | | (m ³ /h) | (ft ³ /min) | |
| ACS580-07-0145A-4 | R6 | 2487 | 685 | 403 | 67 |
| ACS580-07-0169A-4 | R7 | 2497 | 700 | 412 | 67 |
| ACS580-07-0206A-4 | R7 | 3314 | 700 | 412 | 67 |
| ACS580-07-0246A-4 | R8 | 3806 | 800 | 471 | 65 |
| ACS580-07-0293A-4 | R8 | 4942 | 800 | 471 | 65 |
| ACS580-07-0363A-4 | R9 | 5868 | 1400 | 824 | 68 |
| ACS580-07-0430A-4 | R9 | 7600 | 1400 | 824 | 68 |
| ACS580-07-0505A-4 | R10 | 8353 | 1900 | 1118 | 72 |
| ACS580-07-0585A-4 | R10 | 9471 | 1900 | 1118 | 72 |
| ACS580-07-0650A-4 | R10 | 11200 | 1900 | 1118 | 72 |
| ACS580-07-0725A-4 | R11 | 11386 | 2400 | 1413 | 72 |
| ACS580-07-0820A-4 | R11 | 13725 | 2400 | 1413 | 72 |
| ACS580-07-0880A-4 | R11 | 15300 | 2620 | 1542 | 71 |

ACS880-01 $U_N = 230\text{ V}$

| Type designation | Frame size | Heat dissipation (W) | Air flow | | Max. Noise (dB(A)) |
|------------------|------------|-------------------------|---------------------|------------------------|-----------------------|
| | | | (m ³ /h) | (ft ³ /min) | |
| ACS880-01-04A6-2 | R1 | 73 | 44 | 26 | 46 |
| ACS880-01-06A6-2 | R1 | 94 | 44 | 26 | 46 |
| ACS880-01-07A5-2 | R1 | 122 | 44 | 26 | 46 |
| ACS880-01-10A6-2 | R1 | 172 | 44 | 26 | 46 |
| ACS880-01-16A8-2 | R2 | 232 | 88 | 52 | 51 |
| ACS880-01-24A3-2 | R2 | 337 | 88 | 52 | 51 |
| ACS880-01-031A-2 | R3 | 457 | 134 | 79 | 57 |
| ACS880-01-046A-2 | R4 | 500 | 134 | 79 | 62 |
| ACS880-01-061A-2 | R4 | 630 | 280 | 165 | 62 |
| ACS880-01-075A-2 | R5 | 680 | 280 | 165 | 62 |
| ACS880-01-087A-2 | R5 | 730 | 280 | 165 | 62 |
| ACS880-01-115A-2 | R6 | 840 | 435 | 256 | 67 |
| ACS880-01-145A-2 | R6 | 940 | 435 | 256 | 67 |
| ACS880-01-170A-2 | R7 | 1260 | 450 | 265 | 67 |
| ACS880-01-206A-2 | R7 | 1500 | 450 | 265 | 67 |
| ACS880-01-274A-2 | R8 | 2100 | 550 | 324 | 65 |

ACS880-01 $U_N = 400\text{ V}$

| Type designation | Frame size | Heat dissipation (W) | Air flow | | Max. Noise (dB(A)) |
|------------------|------------|-------------------------|---------------------|------------------------|-----------------------|
| | | | (m ³ /h) | (ft ³ /min) | |
| ACS880-01-02A4-3 | R1 | 30 | 44 | 26 | 46 |
| ACS880-01-03A3-3 | R1 | 40 | 44 | 26 | 46 |
| ACS880-01-04A0-3 | R1 | 52 | 44 | 26 | 46 |
| ACS880-01-05A6-3 | R1 | 73 | 44 | 26 | 46 |
| ACS880-01-07A2-3 | R1 | 94 | 44 | 26 | 46 |
| ACS880-01-09A4-3 | R1 | 122 | 44 | 26 | 46 |
| ACS880-01-12A6-3 | R1 | 172 | 44 | 26 | 46 |
| ACS880-01-017A-3 | R2 | 232 | 88 | 52 | 51 |
| ACS880-01-025A-3 | R2 | 337 | 88 | 52 | 51 |
| ACS880-01-032A-3 | R3 | 457 | 134 | 79 | 57 |
| ACS880-01-038A-3 | R3 | 562 | 134 | 79 | 57 |
| ACS880-01-045A-3 | R4 | 667 | 134 | 79 | 62 |
| ACS880-01-061A-3 | R4 | 907 | 280 | 165 | 62 |
| ACS880-01-072A-3 | R5 | 1117 | 280 | 165 | 62 |
| ACS880-01-087A-3 | R5 | 1120 | 280 | 165 | 62 |
| ACS880-01-105A-3 | R6 | 1295 | 435 | 256 | 67 |
| ACS880-01-145A-3 | R6 | 1440 | 435 | 256 | 67 |
| ACS880-01-169A-3 | R7 | 1940 | 450 | 265 | 67 |
| ACS880-01-206A-3 | R7 | 2310 | 450 | 265 | 67 |
| ACS880-01-246A-3 | R8 | 3300 | 550 | 324 | 65 |
| ACS880-01-293A-3 | R8 | 3900 | 550 | 324 | 65 |
| ACS880-01-363A-3 | R9 | 4800 | 1150 | 677 | 68 |
| ACS880-01-430A-3 | R9 | 6000 | 1150 | 677 | 68 |

ACS880-01 **$U_N = 500\text{ V}$**

| Type designation | Frame size | Heat dissipation (W) | Air flow | | Max. Noise (dB(A)) |
|------------------|------------|-------------------------|---------------------|------------------------|-----------------------|
| | | | (m ³ /h) | (ft ³ /min) | |
| ACS880-01-02A1-5 | R1 | 30 | 44 | 26 | 46 |
| ACS880-01-03A0-5 | R1 | 40 | 44 | 26 | 46 |
| ACS880-01-03A4-5 | R1 | 52 | 44 | 26 | 46 |
| ACS880-01-04A8-5 | R1 | 73 | 44 | 26 | 46 |
| ACS880-01-05A2-5 | R1 | 94 | 44 | 26 | 46 |
| ACS880-01-07A6-5 | R1 | 122 | 44 | 26 | 46 |
| ACS880-01-11A0-5 | R1 | 172 | 44 | 26 | 46 |
| ACS880-01-014A-5 | R2 | 232 | 88 | 52 | 51 |
| ACS880-01-021A-5 | R2 | 337 | 88 | 52 | 51 |
| ACS880-01-027A-5 | R3 | 457 | 134 | 79 | 57 |
| ACS880-01-034A-5 | R3 | 562 | 134 | 79 | 57 |
| ACS880-01-040A-5 | R4 | 667 | 134 | 79 | 62 |
| ACS880-01-052A-5 | R4 | 907 | 280 | 165 | 62 |
| ACS880-01-065A-5 | R5 | 1117 | 280 | 165 | 62 |
| ACS880-01-077A-5 | R5 | 1120 | 280 | 165 | 62 |
| ACS880-01-096A-5 | R6 | 1295 | 435 | 256 | 67 |
| ACS880-01-124A-5 | R6 | 1440 | 435 | 256 | 67 |
| ACS880-01-156A-5 | R7 | 1940 | 450 | 265 | 67 |
| ACS880-01-180A-5 | R7 | 2310 | 450 | 265 | 67 |
| ACS880-01-240A-5 | R8 | 3300 | 550 | 324 | 65 |
| ACS880-01-260A-5 | R8 | 3900 | 550 | 324 | 65 |
| ACS880-01-361A-5 | R9 | 4200 | 1150 | 677 | 68 |
| ACS880-01-414A-5 | R9 | 4800 | 1150 | 677 | 68 |

ACS880-01 **$U_N = 690\text{ V}$**

| Type designation | Frame size | Heat dissipation (W) | Air flow | | Max. Noise (dB(A)) |
|------------------|------------|-------------------------|---------------------|------------------------|-----------------------|
| | | | (m ³ /h) | (ft ³ /min) | |
| ACS880-01-07A3-7 | R5 | 217 | 280 | 165 | 62 |
| ACS880-01-09A8-7 | R5 | 284 | 280 | 165 | 62 |
| ACS880-01-14A2-7 | R5 | 399 | 280 | 165 | 62 |
| ACS880-01-018A-7 | R5 | 490 | 280 | 165 | 62 |
| ACS880-01-022A-7 | R5 | 578 | 280 | 165 | 62 |
| ACS880-01-026A-7 | R5 | 660 | 280 | 165 | 62 |
| ACS880-01-035A-7 | R5 | 864 | 280 | 165 | 62 |
| ACS880-01-042A-7 | R5 | 998 | 280 | 165 | 62 |
| ACS880-01-049A-7 | R5 | 1120 | 280 | 165 | 62 |
| ACS880-01-061A-7 | R6 | 1295 | 435 | 256 | 67 |
| ACS880-01-084A-7 | R6 | 1440 | 435 | 256 | 67 |
| ACS880-01-098A-7 | R7 | 1940 | 450 | 265 | 67 |
| ACS880-01-119A-7 | R7 | 2310 | 450 | 265 | 67 |
| ACS880-01-142A-7 | R8 | 3300 | 550 | 324 | 65 |
| ACS880-01-174A-7 | R8 | 3900 | 550 | 324 | 65 |
| ACS880-01-210A-7 | R9 | 4200 | 1150 | 677 | 68 |
| ACS880-01-271A-7 | R9 | 4800 | 1150 | 677 | 68 |

| ACS880-04 | | | | | |
|----------------------|------------|----------------------|---------------------|------------------------|---------------------|
| $U_N = 400\text{ V}$ | | | | | |
| Type designation | Frame size | Heat dissipation (W) | Air flow | | Max. Noise (dB (A)) |
| | | | (m ³ /h) | (ft ³ /min) | |
| ACS880-04-505A-3 | R10 | 5602 | 1200 | 707 | 72 |
| ACS880-04-585A-3 | R10 | 6409 | 1200 | 707 | 72 |
| ACS880-04-650A-3 | R10 | 8122 | 1200 | 707 | 72 |
| ACS880-04-725A-3 | R11 | 8764 | 1200 | 707 | 72 |
| ACS880-04-820A-3 | R11 | 9862 | 1200 | 707 | 72 |
| ACS880-04-880A-3 | R11 | 10578 | 1420 | 836 | 71 |

| ACS880-04 | | | | | |
|----------------------|------------|----------------------|---------------------|------------------------|---------------------|
| $U_N = 500\text{ V}$ | | | | | |
| Type designation | Frame size | Heat dissipation (W) | Air flow | | Max. Noise (dB (A)) |
| | | | (m ³ /h) | (ft ³ /min) | |
| ACS880-04-460A-5 | R10 | 4403 | 1200 | 707 | 72 |
| ACS880-04-503A-5 | R10 | 5602 | 1200 | 707 | 72 |
| ACS880-04-583A-5 | R10 | 6409 | 1200 | 707 | 72 |
| ACS880-04-635A-5 | R10 | 8122 | 1200 | 707 | 72 |
| ACS880-04-715A-5 | R11 | 8764 | 1200 | 707 | 72 |
| ACS880-04-820A-5 | R11 | 9862 | 1420 | 836 | 71 |
| ACS880-04-880A-5 | R11 | 10578 | 1420 | 836 | 71 |

| ACS880-04 | | | | | |
|----------------------|------------|----------------------|---------------------|------------------------|---------------------|
| $U_N = 690\text{ V}$ | | | | | |
| Type designation | Frame size | Heat dissipation (W) | Air flow | | Max. Noise (dB (A)) |
| | | | (m ³ /h) | (ft ³ /min) | |
| ACS880-04-330A-7 | R10 | 4403 | 1200 | 707 | 72 |
| ACS880-04-370A-7 | R10 | 5602 | 1200 | 707 | 72 |
| ACS880-04-430A-7 | R10 | 6409 | 1200 | 707 | 72 |
| ACS880-04-470A-7 | R11 | 8122 | 1200 | 707 | 72 |
| ACS880-04-522A-7 | R11 | 8764 | 1200 | 707 | 72 |
| ACS880-04-590A-7 | R11 | 9862 | 1200 | 707 | 71 |
| ACS880-04-650A-7 | R11 | 10578 | 1420 | 836 | 71 |
| ACS880-04-721A-7 | R11 | 10578 | 1420 | 836 | 71 |

| ACS880-04F | | | | | | |
|----------------------|------------|------------------|-----------|------------------------------|---------------------------|---------------------|
| $U_N = 400\text{ V}$ | | | | | | |
| Type designation | Frame size | Heat dissipation | | Air flow | | Max. Noise (dB (A)) |
| | | Heatsink (W) | Front (W) | Heatsink (m ³ /h) | Front (m ³ /h) | |
| ACS880-04F-504A-3 | R11 | 5100 | 550 | 1400 | 120 | 75 |
| ACS880-04F-584A-3 | R11 | 5800 | 650 | 1400 | 120 | 75 |
| ACS880-04F-649A-3 | R11 | 7400 | 750 | 1400 | 120 | 75 |
| ACS880-04F-725A-3 | R11 | 7950 | 850 | 1400 | 120 | 75 |
| ACS880-04F-820A-3 | R11 | 8950 | 950 | 1400 | 120 | 75 |
| ACS880-04F-880A-3 | R11 | 9600 | 1000 | 1400 | 120 | 75 |

| ACS880-04F | | | | | | |
|----------------------|------------|------------------|-----------|------------------------------|---------------------------|---------------------|
| $U_N = 500\text{ V}$ | | | | | | |
| Type designation | Frame size | Heat dissipation | | Air flow | | Max. Noise (dB (A)) |
| | | Heatsink (W) | Front (W) | Heatsink (m ³ /h) | Front (m ³ /h) | |
| ACS880-04F-459A-5 | R11 | 3900 | 550 | 1400 | 120 | 75 |
| ACS880-04F-502A-5 | R11 | 5050 | 600 | 1400 | 120 | 75 |
| ACS880-04F-582A-5 | R11 | 5750 | 700 | 1400 | 120 | 75 |
| ACS880-04F-634A-5 | R11 | 7350 | 800 | 1400 | 120 | 75 |
| ACS880-04F-715A-5 | R11 | 7900 | 900 | 1400 | 120 | 75 |
| ACS880-04F-820A-5 | R11 | 8900 | 1000 | 1400 | 120 | 75 |
| ACS880-04F-880A-5 | R11 | 10050 | 1050 | 1400 | 120 | 75 |

| ACS880-04F | | | | | | |
|----------------------|------------|------------------|-----------|------------------------------|---------------------------|---------------------|
| $U_N = 690\text{ V}$ | | | | | | |
| Type designation | Frame size | Heat dissipation | | Air flow | | Max. Noise (dB (A)) |
| | | Heatsink (W) | Front (W) | Heatsink (m ³ /h) | Front (m ³ /h) | |
| ACS880-04F-330A-7 | R11 | 4403 | – | 1400 | – | 72 |
| ACS880-04F-370A-7 | R11 | 5602 | – | 1200 | – | 72 |
| ACS880-04F-430A-7 | R11 | 6409 | – | 1200 | – | 72 |
| ACS880-04F-470A-7 | R11 | 8122 | – | 1200 | – | 72 |
| ACS880-04F-522A-7 | R11 | 8764 | – | 1200 | – | 72 |
| ACS880-04F-590A-7 | R11 | 9862 | – | 1200 | – | 72 |
| ACS880-04F-650A-7 | R11 | 10578 | – | 1420 | – | 72 |
| ACS880-04F-721A-7 | R11 | 10578 | – | 1420 | – | 72 |

ACS880-04FXT $U_N = 400\text{ V}$

| Type designation | Frame size | Heat dissipation per module | | Air flow per module | | Max. Noise | |
|----------------------|------------|-----------------------------|-----------|------------------------------|---------------------------|-----------------------|----------------|
| | | Heatsink (W) | Front (W) | Heatsink (m ³ /h) | Front (m ³ /h) | Drive module (dB (A)) | Drive (dB (A)) |
| ACS880-04FXT-1008A-3 | 2×R11 | 5800 | 650 | 1400 | 120 | 75 | 78 |
| ACS880-04FXT-1188A-3 | 2×R11 | 7400 | 750 | 1400 | 120 | 75 | 78 |
| ACS880-04FXT-1330A-3 | 2×R11 | 7950 | 850 | 1400 | 120 | 75 | 78 |
| ACS880-04FXT-1610A-3 | 2×R11 | 9600 | 1000 | 1400 | 120 | 75 | 78 |

ACS880-04FXT $U_N = 500\text{ V}$

| Type designation | Frame size | Heat dissipation per module | | Air flow per module | | Max. Noise | |
|----------------------|------------|-----------------------------|-----------|------------------------------|---------------------------|-----------------------|----------------|
| | | Heatsink (W) | Front (W) | Heatsink (m ³ /h) | Front (m ³ /h) | Drive module (dB (A)) | Drive (dB (A)) |
| ACS880-04FXT-1008A-5 | 2×R11 | 5750 | 700 | 1400 | 120 | 75 | 78 |
| ACS880-04FXT-1158A-5 | 2×R11 | 7350 | 800 | 1400 | 120 | 75 | 78 |
| ACS880-04FXT-1310A-5 | 2×R11 | 7900 | 900 | 1400 | 120 | 75 | 78 |
| ACS880-04FXT-1610A-5 | 2×R11 | 10050 | 1050 | 1400 | 120 | 75 | 78 |

ACS880-04FXT $U_N = 690\text{ V}$

| Type designation | Frame size | Heat dissipation per module | | Air flow per module | | Max. Noise | |
|----------------------|------------|-----------------------------|-----------|------------------------------|---------------------------|-----------------------|----------------|
| | | Heatsink (W) | Front (W) | Heatsink (m ³ /h) | Front (m ³ /h) | Drive module (dB (A)) | Drive (dB (A)) |
| ACS880-04FXT-0808A-7 | 2×R11 | 5750 | 700 | 1400 | 120 | 75 | 78 |
| ACS880-04FXT-0960A-7 | 2×R11 | 7900 | 900 | 1400 | 120 | 75 | 78 |
| ACS880-04FXT-1080A-7 | 2×R11 | 8900 | 1000 | 1400 | 120 | 75 | 78 |
| ACS880-04FXT-1320A-7 | 2×R11 | 10050 | 1050 | 1400 | 120 | 75 | 78 |

The cooling air temperature rises 30 °C when it goes through the drive module if the temperature of the input cooling air is 40 °C.

ACS880-04XT $U_N = 400\text{ V}$

| Type designation | Frame size | Heat dissipation (W) | Air flow | | Max. Noise | |
|---------------------|------------|-------------------------|---------------------|------------------------|--------------------------|-------------------|
| | | | (m ³ /h) | (ft ³ /min) | Drive module (dB (A)) | Drive (dB (A)) |
| ACS880-04XT-1010A-3 | 2×R10 | 9926 | 2400 | 1414 | 72 | 75 |
| ACS880-04XT-1190A-3 | 2×R10 | 14049 | 2400 | 1414 | 72 | 75 |
| ACS880-04XT-1330A-3 | 2×R11 | 15160 | 2400 | 1414 | 72 | 75 |
| ACS880-04XT-1610A-3 | 2×R11 | 18336 | 2840 | 1672 | 71 | 74 |

ACS880-04XT $U_N = 500\text{ V}$

| Type designation | Frame size | Heat dissipation (W) | Air flow | | Max. Noise | |
|---------------------|------------|-------------------------|---------------------|------------------------|--------------------------|-------------------|
| | | | (m ³ /h) | (ft ³ /min) | Drive module (dB (A)) | Drive (dB (A)) |
| ACS880-04XT-1010A-5 | 2×R10 | 9926 | 2400 | 1414 | 72 | 75 |
| ACS880-04XT-1160A-5 | 2×R10 | 14049 | 2400 | 1414 | 72 | 75 |
| ACS880-04XT-1310A-5 | 2×R11 | 15160 | 2400 | 1414 | 72 | 75 |
| ACS880-04XT-1610A-5 | 2×R11 | 18336 | 2840 | 1672 | 71 | 74 |

ACS880-04XT $U_N = 690\text{ V}$

| Type designation | Frame size | Heat dissipation (W) | Air flow | | Max. Noise | |
|---------------------|------------|-------------------------|---------------------|------------------------|--------------------------|-------------------|
| | | | (m ³ /h) | (ft ³ /min) | Drive module (dB (A)) | Drive (dB (A)) |
| ACS880-04XT-0810A-7 | 2×R10 | 12815 | 2400 | 1414 | 72 | 75 |
| ACS880-04XT-0960A-7 | 2×R11 | 11915 | 2400 | 1414 | 72 | 75 |
| ACS880-04XT-1080A-7 | 2×R11 | 14653 | 2400 | 1414 | 72 | 75 |
| ACS880-04XT-1320A-7 | 2×R11 | 18469 | 2840 | 1672 | 71 | 74 |

ACS880-04FNEMA RATINGS $U_N = 460\text{ V}$

| Type designation | Frame size | Heat dissipation | | Air flow | | Max. Noise (dB (A)) |
|-------------------|------------|------------------|--------------|---------------------------------|------------------------------|------------------------|
| | | Heatsink (W) | Front (W) | Heatsink (m ³ /h) | Front (m ³ /h) | |
| ACS880-04F-502A-5 | R11 | 5050 | 600 | 1400 | 120 | 75 |
| ACS880-04F-582A-5 | R11 | 5750 | 700 | 1400 | 120 | 75 |
| ACS880-04F-634A-5 | R11 | 7350 | 800 | 1400 | 120 | 75 |
| ACS880-04F-715A-5 | R11 | 7900 | 900 | 1400 | 120 | 75 |
| ACS880-04F-820A-5 | R11 | 8900 | 1000 | 1400 | 120 | 75 |
| ACS880-04F-880A-5 | R11 | 10050 | 1050 | 1400 | 120 | 75 |

ACS880-04FNEMA RATINGS $U_N = 600\text{ V}$

| Type designation | Frame size | Heat dissipation | | Air flow | | Max. Noise (dB (A)) |
|-------------------|------------|------------------|--------------|---------------------------------|------------------------------|------------------------|
| | | Heatsink (W) | Front (W) | Heatsink (m ³ /h) | Front (m ³ /h) | |
| ACS880-04F-330A-7 | R11 | 4403 | – | 1400 | – | 72 |
| ACS880-04F-370A-7 | R11 | 5602 | – | 1200 | – | 72 |
| ACS880-04F-430A-7 | R11 | 6409 | – | 1200 | – | 72 |
| ACS880-04F-470A-7 | R11 | 8122 | – | 1200 | – | 72 |
| ACS880-04F-522A-7 | R11 | 8764 | – | 1200 | – | 72 |
| ACS880-04F-590A-7 | R11 | 9862 | – | 1200 | – | 72 |
| ACS880-04F-650A-7 | R11 | 10578 | – | 1420 | – | 72 |
| ACS880-04F-721A-7 | R11 | 10578 | – | 1420 | – | 72 |

ACS880-07 $U_N = 400\text{ V}$

| Type designation | Frame size | Heat dissipation (W) | Air flow | | Max. Noise (dB(A)) |
|-------------------|------------|-------------------------|---------------------|------------------------|-----------------------|
| | | | (m ³ /h) | (ft ³ /min) | |
| ACS880-07-0105A-3 | R6 | 1795 | 1750 | 1030 | 67 |
| ACS880-07-0145A-3 | R6 | 1940 | 1750 | 1030 | 67 |
| ACS880-07-0169A-3 | R7 | 2440 | 1750 | 1030 | 67 |
| ACS880-07-0206A-3 | R7 | 2810 | 1750 | 1030 | 67 |
| ACS880-07-0246A-3 | R8 | 3800 | 1750 | 1030 | 65 |
| ACS880-07-0293A-3 | R8 | 4400 | 1750 | 1030 | 65 |
| ACS880-07-0363A-3 | R9 | 5300 | 1150 | 677 | 68 |
| ACS880-07-0430A-3 | R9 | 6500 | 1150 | 677 | 68 |
| ACS880-07-0505A-3 | R10 | 6102 | 2950 | 1736 | 72 |
| ACS880-07-0585A-3 | R10 | 6909 | 2950 | 1736 | 72 |
| ACS880-07-0650A-3 | R10 | 8622 | 2950 | 1736 | 72 |
| ACS880-07-0725A-3 | R11 | 9264 | 2950 | 1736 | 72 |
| ACS880-07-0820A-3 | R11 | 10362 | 2950 | 1736 | 72 |
| ACS880-07-0880A-3 | R11 | 11078 | 3170 | 1866 | 71 |

ACS880-07 $U_N = 500\text{ V}$

| Type designation | Frame size | Heat dissipation (W) | Air flow | | Max. Noise (dB(A)) |
|-------------------|------------|-------------------------|---------------------|------------------------|-----------------------|
| | | | (m ³ /h) | (ft ³ /min) | |
| ACS880-07-0096A-5 | R6 | 1795 | 1750 | 1030 | 67 |
| ACS880-07-0124A-5 | R6 | 1940 | 1750 | 1030 | 67 |
| ACS880-07-0156A-5 | R7 | 2440 | 1750 | 1030 | 67 |
| ACS880-07-0180A-5 | R7 | 2810 | 1750 | 1030 | 67 |
| ACS880-07-0240A-5 | R8 | 3800 | 1750 | 1030 | 65 |
| ACS880-07-0260A-5 | R8 | 4400 | 1750 | 1030 | 65 |
| ACS880-07-0302A-5 | R9 | 4700 | 1150 | 677 | 68 |
| ACS880-07-0361A-5 | R9 | 5300 | 1150 | 677 | 68 |
| ACS880-07-0414A-5 | R9 | 6500 | 1150 | 677 | 68 |
| ACS880-07-0460A-5 | R10 | 4903 | 2950 | 1736 | 72 |
| ACS880-07-0503A-5 | R10 | 6102 | 2950 | 1736 | 72 |
| ACS880-07-0583A-5 | R10 | 6909 | 2950 | 1736 | 72 |
| ACS880-07-0635A-5 | R10 | 8622 | 2950 | 1736 | 72 |
| ACS880-07-0715A-5 | R11 | 9264 | 2950 | 1736 | 72 |
| ACS880-07-0820A-5 | R11 | 10362 | 2950 | 1736 | 71 |
| ACS880-07-0880A-5 | R11 | 11078 | 2950 | 1736 | 71 |

ACS880-07 $U_N = 690\text{ V}$

| Type designation | Frame size | Heat dissipation (W) | Air flow | | Max. Noise (dB(A)) |
|-------------------|------------|-------------------------|---------------------|------------------------|-----------------------|
| | | | (m ³ /h) | (ft ³ /min) | |
| ACS880-07-0061A-7 | R6 | 1795 | 1750 | 1030 | 67 |
| ACS880-07-0084A-7 | R6 | 1940 | 1750 | 1030 | 67 |
| ACS880-07-0098A-7 | R7 | 2440 | 1750 | 1030 | 67 |
| ACS880-07-0119A-7 | R7 | 2810 | 1750 | 1030 | 67 |
| ACS880-07-0142A-7 | R8 | 3800 | 1750 | 1030 | 65 |
| ACS880-07-0174A-7 | R8 | 4400 | 1750 | 1030 | 65 |
| ACS880-07-0210A-7 | R9 | 4700 | 1150 | 677 | 68 |
| ACS880-07-0271A-7 | R9 | 5300 | 1150 | 677 | 68 |
| ACS880-07-0330A-7 | R10 | 5640 | 2950 | 1736 | 72 |
| ACS880-07-0370A-7 | R10 | 6371 | 2950 | 1736 | 72 |
| ACS880-07-0430A-7 | R10 | 7570 | 2950 | 1837 | 72 |
| ACS880-07-0470A-7 | R11 | 6611 | 2950 | 1736 | 72 |
| ACS880-07-0522A-7 | R11 | 7388 | 2950 | 1736 | 72 |
| ACS880-07-0590A-7 | R11 | 8971 | 2950 | 1736 | 71 |
| ACS880-07-0650A-7 | R11 | 9980 | 3170 | 1866 | 71 |
| ACS880-07-0721A-7 | R11 | 11177 | 3170 | 1866 | 71 |

ACS880-07 with sine filter (+E206) $U_N = 400\text{ V}$

| Type designation | Frame size | Sine filter type | Heat dissipation (kW) | Air flow | | | Max. Noise (dB(A)) |
|-------------------|------------|------------------|--------------------------|------------------------------|-------------------------------|------------------------------|-----------------------|
| | | | | Drive (m ³ /h) | Filter (m ³ /h) | Total (m ³ /h) | |
| ACS880-07-0105A-3 | R6 | B84143V0130R230 | 0.6 | 1750 | *) | 1750 | 80 |
| ACS880-07-0145A-3 | R6 | B84143V0162R229 | 0.55 | 1750 | *) | 1750 | 80 |
| ACS880-07-0169A-3 | R7 | B84143V0162R229 | 0.55 | 1750 | *) | 1750 | 80 |
| ACS880-07-0206A-3 | R7 | B84143V0230R229 | 0.9 | 1750 | *) | 1750 | 80 |
| ACS880-07-0246A-3 | R8 | B84143V0230R229 | 0.9 | 1750 | *) | 1750 | 80 |
| ACS880-07-0293A-3 | R8 | B84143V0390R229 | 1.6 | 1750 | *) | 1750 | 80 |
| ACS880-07-0363A-3 | R9 | B84143V0390R229 | 1.6 | 1150 | *) | 1150 | 80 |
| ACS880-07-0430A-3 | R9 | B84143V0390R229 | 1.6 | 1150 | *) | 1150 | 80 |
| ACS880-07-0505A-3 | R10 | NSIN0900-6 | 3.0 | 2950 | 2000 | 4950 | 80 |
| ACS880-07-0585A-3 | R10 | NSIN0900-6 | 3.4 | 2950 | 2000 | 4950 | 80 |
| ACS880-07-0650A-3 | R10 | NSIN0900-6 | 3.8 | 2950 | 2000 | 4950 | 80 |
| ACS880-07-0725A-3 | R11 | NSIN0900-6 | 4.1 | 2950 | 2000 | 4950 | 80 |
| ACS880-07-0820A-3 | R11 | NSIN0900-6 | 4.7 | 2950 | 2000 | 4950 | 80 |
| ACS880-07-0880A-3 | R11 | NSIN0900-6 | 5.0 | 3170 | 2000 | 5170 | 80 |

ACS880-07 with sine filter (+E206) $U_N = 500\text{ V}$

| Type designation | Frame size | Sine filter type | Heat dissipation (kW) | Air flow | | | Max. Noise (dB(A)) |
|-------------------|------------|------------------|--------------------------|------------------------------|-------------------------------|------------------------------|-----------------------|
| | | | | Drive (m ³ /h) | Filter (m ³ /h) | Total (m ³ /h) | |
| ACS880-07-0096A-5 | R6 | B84143V0130R230 | 0.63 | 1750 | *) | 1750 | 80 |
| ACS880-07-0124A-5 | R6 | B84143V0130R230 | 0.63 | 1750 | *) | 1750 | 80 |
| ACS880-07-0156A-5 | R7 | B84143V0162R229 | 0.55 | 1750 | *) | 1750 | 80 |
| ACS880-07-0180A-5 | R7 | B84143V0162R229 | 0.55 | 1750 | *) | 1750 | 80 |
| ACS880-07-0240A-5 | R8 | B84143V0230R229 | 0.9 | 1750 | *) | 1750 | 80 |
| ACS880-07-0260A-5 | R8 | B84143V0230R229 | 0.9 | 1750 | *) | 1750 | 80 |
| ACS880-07-0361A-5 | R9 | B84143V0390R229 | 1.6 | 1150 | *) | 1150 | 80 |
| ACS880-07-0414A-5 | R9 | B84143V0390R229 | 1.6 | 1150 | *) | 1150 | 80 |
| ACS880-07-0460A-5 | R10 | NSIN0485-6 | 3.3 | 2950 | 700 | 3650 | 80 |
| ACS880-07-0503A-5 | R10 | NSIN0900-6 | 3.6 | 2950 | 2000 | 4950 | 80 |
| ACS880-07-0583A-5 | R10 | NSIN0900-6 | 3.9 | 2950 | 2000 | 4950 | 80 |
| ACS880-07-0635A-5 | R10 | NSIN0900-6 | 4.3 | 2950 | 2000 | 4950 | 80 |
| ACS880-07-0715A-5 | R11 | NSIN0900-6 | 4.9 | 2950 | 2000 | 4950 | 80 |
| ACS880-07-0820A-5 | R11 | NSIN0900-6 | 5.6 | 2950 | 2000 | 4950 | 80 |
| ACS880-07-0880A-5 | R11 | NSIN0900-6 | 5.6 | 2950 | 2000 | 4950 | 80 |

*) Natural convection. Sine filter is not available for ACS880-07-0302A-5.

ACS880-07 with sine filter (+E206) $U_N = 690\text{ V}$

| Type designation | Frame size | Sine filter type | Heat dissipation (kW) | Air flow | | | Max. Noise (dB(A)) |
|-------------------|------------|------------------|--------------------------|------------------------------|-------------------------------|------------------------------|-----------------------|
| | | | | Drive (m ³ /h) | Filter (m ³ /h) | Total (m ³ /h) | |
| ACS880-07-0061A-7 | R6 | B84143V0056R230 | 0.3 | 1750 | *) | 1750 | 78 |
| ACS880-07-0084A-7 | R6 | B84143V0092R230 | 0.6 | 1750 | *) | 1750 | 79 |
| ACS880-07-0098A-7 | R7 | B84143V0092R230 | 0.61 | 1750 | *) | 1750 | 79 |
| ACS880-07-0119A-7 | R7 | B84143V0130R230 | 0.63 | 1750 | *) | 1750 | 80 |
| ACS880-07-0142A-7 | R8 | B84143V0130R230 | 0.6 | 1750 | *) | 1750 | 80 |
| ACS880-07-0174A-7 | R8 | B84143V0207R230 | 0.9 | 1750 | *) | 1750 | 80 |
| ACS880-07-0210A-7 | R9 | B84143V0207R230 | 0.9 | 1150 | *) | 1150 | 80 |
| ACS880-07-0271A-7 | R9 | B84143V0207R230 | 0.9 | 1150 | *) | 1150 | 80 |
| ACS880-07-0330A-7 | R10 | NSIN0485-6 | 2.2 | 2950 | 700 | 3650 | 80 |
| ACS880-07-0370A-7 | R10 | NSIN0485-6 | 2.3 | 2950 | 700 | 3650 | 80 |
| ACS880-07-0430A-7 | R10 | NSIN0485-6 | 2.4 | 2950 | 700 | 3650 | 80 |
| ACS880-07-0470A-7 | R11 | NSIN0485-6 | 3.2 | 2950 | 700 | 3650 | 80 |
| ACS880-07-0522A-7 | R11 | NSIN0485-6 | 3.6 | 2950 | 700 | 3650 | 80 |
| ACS880-07-0590A-7 | R11 | NSIN0900-6 | 4.0 | 2950 | 2000 | 4950 | 80 |
| ACS880-07-0650A-7 | R11 | NSIN0900-6 | 4.9 | 3170 | 2000 | 5170 | 80 |
| ACS880-07-0721A-7 | R11 | NSIN0900-6 | 4.9 | 3170 | 2000 | 5170 | 80 |

| ACS880-11 | | | | |
|----------------------|------------|----------------------|------------------------------|--------------------|
| $U_N = 400\text{ V}$ | | | | |
| Type designation | Frame size | Heat dissipation (W) | Air flow (m ³ /h) | Max. Noise (dB(A)) |
| ACS880-11-09A4-3 | R3 | 226 | 361 | 57 |
| ACS880-11-12A6-3 | R3 | 329 | 361 | 57 |
| ACS880-11-017A-3 | R3 | 395 | 361 | 57 |
| ACS880-11-025A-3 | R3 | 579 | 361 | 57 |
| ACS880-11-032A-3 | R6 | 625 | 550 | 71 |
| ACS880-11-038A-3 | R6 | 751 | 550 | 71 |
| ACS880-11-045A-3 | R6 | 912 | 550 | 71 |
| ACS880-11-061A-3 | R6 | 1088 | 550 | 71 |
| ACS880-11-072A-3 | R6 | 1502 | 550 | 71 |
| ACS880-11-087A-3 | R6 | 1904 | 550 | 71 |
| ACS880-11-105A-3 | R8 | 1877 | 700 | 68 |
| ACS880-11-145A-3 | R8 | 2963 | 700 | 68 |
| ACS880-11-169A-3 | R8 | 3168 | 700 | 68 |
| ACS880-11-206A-3 | R8 | 3990 | 805 | 68 |

| ACS880-11 | | | | |
|----------------------|------------|----------------------|------------------------------|--------------------|
| $U_N = 500\text{ V}$ | | | | |
| Type designation | Frame size | Heat dissipation (W) | Air flow (m ³ /h) | Max. Noise (dB(A)) |
| ACS880-11-07A6-5 | R3 | 219 | 361 | 57 |
| ACS880-11-11A0-5 | R3 | 278 | 361 | 57 |
| ACS880-11-014A-5 | R3 | 321 | 361 | 57 |
| ACS880-11-021A-5 | R3 | 473 | 361 | 57 |
| ACS880-11-027A-5 | R6 | 625 | 550 | 71 |
| ACS880-11-034A-5 | R6 | 711 | 550 | 71 |
| ACS880-11-040A-5 | R6 | 807 | 550 | 71 |
| ACS880-11-052A-5 | R6 | 960 | 550 | 71 |
| ACS880-11-065A-5 | R6 | 1223 | 550 | 71 |
| ACS880-11-077A-5 | R6 | 1560 | 550 | 71 |
| ACS880-11-101A-5 | R8 | 1995 | 700 | 68 |
| ACS880-11-124A-5 | R8 | 2800 | 700 | 68 |
| ACS880-11-156A-5 | R8 | 3168 | 700 | 68 |
| ACS880-11-180A-5 | R8 | 3872 | 805 | 68 |

| ACS880-14 | | | | |
|----------------------|------------|----------------------|------------------------------|--------------------|
| $U_N = 400\text{ V}$ | | | | |
| Type designation | Frame size | Heat dissipation (W) | Air flow (m ³ /h) | Max. Noise (dB(A)) |
| ACS880-14-246A-3 | R11 | 5280 | 2100 | 75 |
| ACS880-14-293A-3 | R11 | 6400 | 2100 | 75 |
| ACS880-14-363A-3 | R11 | 8000 | 2100 | 75 |
| ACS880-14-442A-3 | R11 | 10000 | 2100 | 75 |
| ACS880-14-505A-3 | R11 | 10000 | 2100 | 75 |
| ACS880-14-585A-3 | R11 | 12600 | 2100 | 75 |
| ACS880-14-650A-3 | R11 | 14200 | 2100 | 75 |

| ACS880-14 | | | | |
|----------------------|------------|----------------------|------------------------------|--------------------|
| $U_N = 500\text{ V}$ | | | | |
| Type designation | Frame size | Heat dissipation (W) | Air flow (m ³ /h) | Max. Noise (dB(A)) |
| ACS880-14-240A-5 | R11 | 5280 | 2100 | 75 |
| ACS880-14-260A-5 | R11 | 6400 | 2100 | 75 |
| ACS880-14-361A-5 | R11 | 8000 | 2100 | 75 |
| ACS880-14-414A-5 | R11 | 10000 | 2100 | 75 |
| ACS880-14-460A-5 | R11 | 12600 | 2100 | 75 |
| ACS880-14-503A-5 | R11 | 14200 | 2100 | 75 |

| ACS880-14 | | | | |
|----------------------|------------|----------------------|------------------------------|--------------------|
| $U_N = 690\text{ V}$ | | | | |
| Type designation | Frame size | Heat dissipation (W) | Air flow (m ³ /h) | Max. Noise (dB(A)) |
| ACS880-14-142A-7 | R11 | 5280 | 2100 | 75 |
| ACS880-14-174A-7 | R11 | 6400 | 2100 | 75 |
| ACS880-14-210A-7 | R11 | 8000 | 2100 | 75 |
| ACS880-14-271A-7 | R11 | 10000 | 2100 | 75 |
| ACS880-14-330A-7 | R11 | 12600 | 2100 | 75 |
| ACS880-14-370A-7 | R11 | 14200 | 2100 | 75 |
| ACS880-14-430A-7 | R11 | 16000 | 2100 | 75 |

| ACS880-17 | | | | |
|----------------------|------------|----------------------|------------------------------|--------------------|
| $U_N = 400\text{ V}$ | | | | |
| Type designation | Frame size | Heat dissipation (W) | Air flow (m ³ /h) | Max. Noise (dB(A)) |
| ACS880-17-0105A-3 | R8 | 2200 | 700 | 70 |
| ACS880-17-0145A-3 | R8 | 3300 | 700 | 70 |
| ACS880-17-0169A-3 | R8 | 3570 | 700 | 70 |
| ACS880-17-0206A-3 | R8 | 4440 | 805 | 70 |
| ACS880-17-0293A-3 | R11 | 6900 | 2100 | 77 |
| ACS880-17-0363A-3 | R11 | 8500 | 2100 | 77 |
| ACS880-17-0442A-3 | R11 | 10500 | 2100 | 77 |
| ACS880-17-0505A-3 | R11 | 10600 | 2100 | 77 |
| ACS880-17-0585A-3 | R11 | 13200 | 2100 | 77 |
| ACS880-17-0650A-3 | R11 | 14800 | 2100 | 77 |

| ACS880-17 | | | | |
|----------------------|------------|----------------------|------------------------------|--------------------|
| $U_N = 690\text{ V}$ | | | | |
| Type designation | Frame size | Heat dissipation (W) | Air flow (m ³ /h) | Max. Noise (dB(A)) |
| ACS880-17-0174A-7 | R11 | 6900 | 2100 | 77 |
| ACS880-17-0210A-7 | R11 | 8500 | 2100 | 77 |
| ACS880-17-0271A-7 | R11 | 10500 | 2100 | 77 |
| ACS880-17-0330A-7 | R11 | 13000 | 2100 | 77 |
| ACS880-17-0370A-7 | R11 | 14700 | 2100 | 77 |
| ACS880-17-0430A-7 | R11 | 16500 | 2100 | 77 |

| ACS880-31 | | | | |
|----------------------|------------|----------------------|------------------------------|--------------------|
| $U_N = 400\text{ V}$ | | | | |
| Type designation | Frame size | Heat dissipation (W) | Air flow (m ³ /h) | Max. Noise (dB(A)) |
| ACS880-31-09A4-3 | R3 | 226 | 361 | 57 |
| ACS880-31-12A6-3 | R3 | 329 | 361 | 57 |
| ACS880-31-017A-3 | R3 | 395 | 361 | 57 |
| ACS880-31-025A-3 | R3 | 579 | 361 | 57 |
| ACS880-31-032A-3 | R6 | 625 | 550 | 71 |
| ACS880-31-038A-3 | R6 | 751 | 550 | 71 |
| ACS880-31-045A-3 | R6 | 912 | 550 | 71 |
| ACS880-31-061A-3 | R6 | 1088 | 550 | 71 |
| ACS880-31-072A-3 | R6 | 1502 | 550 | 71 |
| ACS880-31-087A-3 | R6 | 1904 | 550 | 71 |
| ACS880-31-105A-3 | R8 | 1877 | 700 | 68 |
| ACS880-31-145A-3 | R8 | 2963 | 700 | 68 |
| ACS880-31-169A-3 | R8 | 3168 | 700 | 68 |
| ACS880-31-206A-3 | R8 | 3990 | 805 | 68 |

| ACS880-17 | | | | |
|----------------------|------------|----------------------|------------------------------|--------------------|
| $U_N = 500\text{ V}$ | | | | |
| Type designation | Frame size | Heat dissipation (W) | Air flow (m ³ /h) | Max. Noise (dB(A)) |
| ACS880-17-0101A-5 | R8 | 2300 | 700 | 70 |
| ACS880-17-0124A-5 | R8 | 3100 | 700 | 70 |
| ACS880-17-0156A-5 | R8 | 3500 | 700 | 70 |
| ACS880-17-0180A-5 | R8 | 4300 | 805 | 70 |
| ACS880-17-0260A-5 | R11 | 6900 | 2100 | 77 |
| ACS880-17-0361A-5 | R11 | 8500 | 2100 | 77 |
| ACS880-17-0414A-5 | R11 | 10500 | 2100 | 77 |
| ACS880-17-0460A-5 | R11 | 13100 | 2100 | 77 |
| ACS880-17-0503A-5 | R11 | 14800 | 2100 | 77 |

| ACS880-31 | | | | |
|----------------------|------------|----------------------|------------------------------|--------------------|
| $U_N = 500\text{ V}$ | | | | |
| Type designation | Frame size | Heat dissipation (W) | Air flow (m ³ /h) | Max. Noise (dB(A)) |
| ACS880-31-07A6-5 | R3 | 219 | 361 | 57 |
| ACS880-31-11A0-5 | R3 | 278 | 361 | 57 |
| ACS880-31-014A-5 | R3 | 321 | 361 | 57 |
| ACS880-31-021A-5 | R3 | 473 | 361 | 57 |
| ACS880-31-027A-5 | R6 | 625 | 550 | 71 |
| ACS880-31-034A-5 | R6 | 711 | 550 | 71 |
| ACS880-31-040A-5 | R6 | 807 | 550 | 71 |
| ACS880-31-052A-5 | R6 | 960 | 550 | 71 |
| ACS880-31-065A-5 | R6 | 1223 | 550 | 71 |
| ACS880-31-077A-5 | R6 | 1560 | 550 | 71 |
| ACS880-31-101A-5 | R8 | 1995 | 700 | 68 |
| ACS880-31-124A-5 | R8 | 2800 | 700 | 68 |
| ACS880-31-156A-5 | R8 | 3168 | 700 | 68 |
| ACS880-31-180A-5 | R8 | 3872 | 805 | 68 |

| ACS880-34 | | | | |
|----------------------|------------|----------------------|------------------------------|--------------------|
| $U_n = 400\text{ V}$ | | | | |
| Type designation | Frame size | Heat dissipation (W) | Air flow (m ³ /h) | Max. Noise (dB(A)) |
| ACS880-34-246A-3 | R11 | 5280 | 2100 | 75 |
| ACS880-34-293A-3 | R11 | 6400 | 2100 | 75 |
| ACS880-34-363A-3 | R11 | 8000 | 2100 | 75 |
| ACS880-34-442A-3 | R11 | 10000 | 2100 | 75 |
| ACS880-34-505A-3 | R11 | 10000 | 2100 | 75 |
| ACS880-34-585A-3 | R11 | 12600 | 2100 | 75 |
| ACS880-34-650A-3 | R11 | 14200 | 2100 | 75 |

| ACS880-34 | | | | |
|----------------------|------------|----------------------|------------------------------|--------------------|
| $U_n = 690\text{ V}$ | | | | |
| Type designation | Frame size | Heat dissipation (W) | Air flow (m ³ /h) | Max. Noise (dB(A)) |
| ACS880-34-142A-7 | R11 | 5280 | 2100 | 75 |
| ACS880-34-174A-7 | R11 | 6400 | 2100 | 75 |
| ACS880-34-210A-7 | R11 | 8000 | 2100 | 75 |
| ACS880-34-271A-7 | R11 | 10000 | 2100 | 75 |
| ACS880-34-330A-7 | R11 | 12600 | 2100 | 75 |
| ACS880-34-370A-7 | R11 | 14200 | 2100 | 75 |
| ACS880-34-430A-7 | R11 | 16000 | 2100 | 75 |

| ACS880-37 | | | | |
|----------------------|------------|----------------------|------------------------------|--------------------|
| $U_n = 400\text{ V}$ | | | | |
| Type designation | Frame size | Heat dissipation (W) | Air flow (m ³ /h) | Max. Noise (dB(A)) |
| ACS880-37-0105A-3 | R8 | 2200 | 700 | 70 |
| ACS880-37-0145A-3 | R8 | 3300 | 700 | 70 |
| ACS880-37-0169A-3 | R8 | 3570 | 700 | 70 |
| ACS880-37-0206A-3 | R8 | 4440 | 805 | 70 |
| ACS880-37-0293A-3 | R11 | 6900 | 2100 | 77 |
| ACS880-37-0363A-3 | R11 | 8500 | 2100 | 77 |
| ACS880-37-0442A-3 | R11 | 10500 | 2100 | 77 |
| ACS880-37-0505A-3 | R11 | 10600 | 2100 | 77 |
| ACS880-37-0585A-3 | R11 | 13200 | 2100 | 77 |
| ACS880-37-0650A-3 | R11 | 14800 | 2100 | 77 |

| ACS880-37 | | | | |
|----------------------|------------|----------------------|------------------------------|--------------------|
| $U_n = 690\text{ V}$ | | | | |
| Type designation | Frame size | Heat dissipation (W) | Air flow (m ³ /h) | Max. Noise (dB(A)) |
| ACS880-37-0174A-7 | R11 | 6900 | 2100 | 77 |
| ACS880-37-0210A-7 | R11 | 8500 | 2100 | 77 |
| ACS880-37-0271A-7 | R11 | 10500 | 2100 | 77 |
| ACS880-37-0330A-7 | R11 | 13000 | 2100 | 77 |
| ACS880-37-0370A-7 | R11 | 14700 | 2100 | 77 |
| ACS880-37-0430A-7 | R11 | 16500 | 2100 | 77 |

| ACS880-34 | | | | |
|----------------------|------------|----------------------|------------------------------|--------------------|
| $U_n = 500\text{ V}$ | | | | |
| Type designation | Frame size | Heat dissipation (W) | Air flow (m ³ /h) | Max. Noise (dB(A)) |
| ACS880-34-240A-5 | R11 | 5280 | 2100 | 75 |
| ACS880-34-260A-5 | R11 | 6400 | 2100 | 75 |
| ACS880-34-361A-5 | R11 | 8000 | 2100 | 75 |
| ACS880-34-414A-5 | R11 | 10000 | 2100 | 75 |
| ACS880-34-460A-5 | R11 | 12600 | 2100 | 75 |
| ACS880-34-503A-5 | R11 | 14200 | 2100 | 75 |

| ACS880-37 | | | | |
|----------------------|------------|----------------------|------------------------------|--------------------|
| $U_n = 500\text{ V}$ | | | | |
| Type designation | Frame size | Heat dissipation (W) | Air flow (m ³ /h) | Max. Noise (dB(A)) |
| ACS880-37-0101A-5 | R8 | 2300 | 700 | 70 |
| ACS880-37-0124A-5 | R8 | 3100 | 700 | 70 |
| ACS880-37-0156A-5 | R8 | 3500 | 700 | 70 |
| ACS880-37-0180A-5 | R8 | 4300 | 805 | 70 |
| ACS880-37-0260A-5 | R11 | 6900 | 2100 | 77 |
| ACS880-37-0361A-5 | R11 | 8500 | 2100 | 77 |
| ACS880-37-0414A-5 | R11 | 10500 | 2100 | 77 |
| ACS880-37-0460A-5 | R11 | 13100 | 2100 | 77 |
| ACS880-37-0503A-5 | R11 | 14800 | 2100 | 77 |

Ambient and installation conditions and deratings, free space requirements

ACS380

| Ambient conditions | | | |
|---|--|---|---|
| | Operation installed for stationary use | Storage in the protective package | Transportation in the protective package |
| Installation site altitude | 230 V units: 0 to 2000 m above sea level (with derating above 1000m). 400 V units: 0 to 4000 m above sea level (with derating above 1000 m).*** | – | – |
| Air temperature | -10...+60 °C (no frost allowed). For frame R0, -10...+50 °C. | -40...+70 °C ±2% | -40...+70 °C ±2% |
| Relative humidity *) | 0...95% | Max. 95% | Max. 95% |
| Contamination levels **) (IEC 60721-3-x) | According to IEC 60721-3-3:2002: Chemical gases: Class 3C2 Solid particles: Class 3S2 ¹⁾ | According to IEC 60721-3-1:1997: Chemical gases: Class 1C2 Solid particles: Class 1S2 | According to IEC 60721-3-2:1997: Chemical gases: Class 2C2 Solid particles: Class 2S2 |
| Pollution degree (IEC 60950-1) | Pollution degree 2 | – | – |
| Sinusoidal vibration (IEC 60721-3-3:2002) | Tested according to IEC 60721-3-3:2002: mechanical conditions: Class 3M4 2...9 Hz, 3.0 mm, 9...200 Hz, 10 m/s ² | – | – |
| Shock (IEC 60068-2-27, ISTA 1A) | Not allowed | According to ISTA 1A Max. 100 m/s ² , 11 ms | According to ISTA 1A Max. 100 m/s ² , 11 ms |
| Free fall | Not allowed | 76 cm | 76 cm |

*) No condensation allowed. Maximum allowed relative humidity is 60 % in the presence of corrosive gases.

**) No conductive dust allowed.

***) See HW manual about restrictions above 2000 m.

¹⁾ Install the drive according to the enclosure classification.

Make sure that the cooling air is clean, and free from corrosive materials and electrically conductive dust.

Switching frequency derating

Current with different switching frequencies (I_{2N} at 50 °C)

| Type designation | Frame size | 2 kHz | 4 kHz | 8 kHz | 12 kHz |
|---|------------|-------|-------|-------|--------|
| 1-phase $U_N = 200-240$ V | | | | | |
| ACS380-04xx-02A4-1 | R0 | 2.4 | 2.4 | 1.9 | 1.6 |
| ACS380-04xx-03A7-1 | R0 | 3.7 | 3.7 | 2.9 | 2.4 |
| ACS380-04xx-04A8-1 | R1 | 4.8 | 4.8 | 3.9 | 3.3 |
| ACS380-04xx-06A9-1 | R1 | 6.9 | 6.9 | 5.6 | 4.7 |
| ACS380-04xx-07A8-1 | R1 | 7.8 | 7.8 | 6.6 | 5.8 |
| ACS380-04xx-09A8-1 | R2 | 9.8 | 9.8 | 8.3 | 7.2 |
| ACS380-04xx-12A2-1 | R2 | 12.2 | 12.2 | 10.0 | 8.4 |
| 3-phase $U_N = 380-480$ V | | | | | |
| ACS380-04xx-01A8-4 | R0 | 1.8 | 1.8 | 1.2 | 0.86 |
| ACS380-04xx-02A6-4 | R1 | 2.6 | 2.6 | 1.7 | 1.2 |
| ACS380-04xx-03A3-4 | R1 | 3.3 | 3.3 | 2.1 | 1.6 |
| ACS380-04xx-04A0-4 | R1 | 4.0 | 4.0 | 2.6 | 1.9 |
| ACS380-04xx-05A6-4 | R1 | 5.6 | 5.6 | 3.6 | 2.7 |
| ACS380-04xx-07A2-4 | R1 | 7.2 | 7.2 | 4.7 | 3.5 |
| ACS380-04xx-09A4-4 | R1 | 9.4 | 9.4 | 6.1 | 4.5 |
| ACS380-04xx-12A6-4 | R2 | 12.6 | 12.6 | 8.5 | 6.4 |
| ACS380-04xx-17A0-4 | R3 | 17.0 | 17.0 | 11.5 | 8.6 |
| ACS380-04xx-25A0-4 | R3 | 25.0 | 25.0 | 16.8 | 12.6 |
| ACS380-04xx-032A-4 | R4 | 32.0 | 32.0 | 21.7 | 16.7 |
| ACS380-04xx-038A-4 | R4 | 38.0 | 38.0 | 24.6 | 18.5 |
| ACS380-04xx-045A-4 | R4 | 45.0 | 45.0 | 29.4 | 21.9 |
| ACS380-04xx-050A-4 | R4 | 50.0 | 50.0 | 32.9 | 24.54 |

^{*)} Frame size R0 with free convection cooling

Surrounding air temperature derating

| Frame size | Temperature | Derating |
|------------|--------------|---|
| R0...R4 | Up to +50 °C | No derating |
| R1...R4 | +50...+60 °C | Output current is decreased by 1% for every additional 1 °C |

Altitude derating

| Units | Derating |
|--------------|---|
| All variants | 0...1000 m no derating |
| 230 V | 1000...2000 m above sea level, the derating is 1% for every 100 m. |
| 400 V | 1000...4000 m above sea level, the derating is 1% for every 100 m ^{*)} |

^{*)} Up to 4000 m altitude is possible for 400 V units when following boundary conditions are taken into account:

- Maximum switching voltage for integrated Relay Output 1 is 30 V at 4000 m altitude (e.g. it is not allowed to connect 250 V to Relay Output 1)
- When using BREL-01 side option module maximum potential difference between adjacent relays is 30 V (e.g. it is not allowed to connect 250 V to Relay Output 2 and 30 V to Relay Output 3)
- If those conditions are not met, maximum altitude is 2000 m
- When using 3ph 400 V ACS380 drive at 4000 m altitude it is only allowed to connect the drive to following power systems: TN-S, TN-c, TN-CS, TT (not corner earthed)

Free space requirements

| Frame size | Above (mm) | Below (mm) | On the sides ¹⁾ (mm) |
|------------|------------|------------|---------------------------------|
| R0...R4 | 75 | 75 | 0 |

ACS480

| Ambient conditions | | | |
|---|--|---|---|
| | Operation installed for stationary use | Storage in the protective package | Transportation in the protective package |
| Installation site altitude | 400/480 V units: 0 to 2000 m above sea level (with derating above 1000 m). ^{***} | – | – |
| Air temperature | -10...+60 °C (no frost allowed). Output is derated above 50 °C. | -40...+70 °C ±2% | -40...+70 °C ±2% |
| Relative humidity ^{*)} | 5...95% | Max. 95% | Max. 95% |
| Contamination levels ^{**)} (IEC 60721-3-x) | According to IEC 60721-3-3:2002: Chemical gases: Class 3C2 Solid particles: Class 3S2 ¹⁾ | According to IEC 60721-3-1:1997: Chemical gases: Class 1C2 Solid particles: Class 1S3 ²⁾ | According to IEC 60721-3-2:1997: Chemical gases: Class 2C2 Solid particles: Class 2S2 |
| Pollution degree (IEC/EN 61800-5-1) | Pollution degree 2 | – | – |
| Sinusoidal vibration (IEC 60068-2-6, Test Fc 2007-12) | Frequency 10...150 Hz; amplitude ±0.075 mm (0.003 in), 10...57,56 Hz; constant peak acceleration 10 m/s ² (33 ft/s ²), 57.56...150 Hz; sweep: 1 oct/min; 10 sweep cycles in each axis with STO active; uncertainty ±5.0%; normal mounting | – | – |
| Shock (IEC 60068-2-27, ISTA 1A) | Not allowed | According to ISTA 1A Max. 100 m/s ² , 11 ms | According to ISTA 1A Max. 100 m/s ² , 11 ms |
| Free fall | – | 76 cm | 76 cm |

^{*)} No condensation allowed. Maximum allowed relative humidity is 60 % in the presence of corrosive gases.

^{**)} No conductive dust allowed.

^{***)} See HW manual about restrictions above 2000 m.

¹⁾ No conductive dust allowed.

²⁾ Packing must support this, otherwise 1S2.

| Switching frequency derating | | | | |
|---|------------|---------|-------|--------|
| Current with different switching frequencies (I_{2N} at 50 °C) | | | | |
| Type designation | Frame size | ≤ 4 kHz | 8 kHz | 12 kHz |
| 3-phase $U_N = 400$ V | | | | |
| ACS480-04-02A7-4 | R1 | 1.0 | 0.65 | 0.48 |
| ACS480-04-03A4-4 | R1 | 1.0 | 0.65 | 0.48 |
| ACS480-04-04A1-4 | R1 | 1.0 | 0.65 | 0.48 |
| ACS480-04-05A7-4 | R1 | 1.0 | 0.65 | 0.48 |
| ACS480-04-07A3-4 | R1 | 1.0 | 0.65 | 0.48 |
| ACS480-04-09A5-4 | R1 | 1.0 | 0.65 | 0.48 |
| ACS480-04-12A7-4 | R2 | 1.0 | 0.68 | 0.51 |
| ACS480-04-018A-4 | R3 | 1.0 | 0.68 | 0.51 |
| ACS480-04-026A-4 | R3 | 1.0 | 0.67 | 0.51 |
| ACS480-04-033A-4 | R4 | 1.0 | 0.65 | 0.49 |
| ACS480-04-039A-4 | R4 | 1.0 | 0.65 | 0.49 |
| ACS480-04-046A-4 | R4 | 1.0 | 0.66 | 0.49 |
| ACS480-04-050A-4 | R4 | 1.0 | 0.66 | 0.49 |

| Surrounding air temperature derating | | |
|--------------------------------------|--------------|--|
| Frame size | Temperature | Derating |
| All | Up to +50 °C | No derating |
| R1...R3 | +50...+60 °C | Output current is decreased by 1% for every additional 1 °C |
| R4 | +50...+60 °C | Output current decreases by 1% for every additional 1 °C on: • ACS480-04-033A-4 • ACS480-04-046A-4 |
| | | Output current decreases by 2% for every additional 1 °C on: • ACS480-04-039A-4 • ACS480-04-050A-4 • ACS480-04-055A-2 |

| Altitude derating |
|--|
| 400 V units: In altitudes 1000...4000 m above sea level, the derating is 1% for every 100 m. In addition: |
| <ul style="list-style-type: none"> • A maximum altitude of 4000 m is permitted for these earthing systems: neutral-grounded TN and TT systems and non-corner grounded IT systems. A maximum altitude of 2000 m is permitted for these earthing systems: corner-grounded TN, TT and IT systems. • Above 2000 m, the maximum permitted voltage for the relay output RO1 decreases. At 4000 m, it is 30 V. • Above 2000 m, the maximum permitted potential difference between the adjacent relays of the BREL-01 relay extension module (option +L511) decreases. At 4000 m, it is 30 V. |

| Free space requirements | | | |
|-------------------------|------------|------------|---------------------------------|
| Frame size | Above (mm) | Below (mm) | On the sides ¹⁾ (mm) |
| All | 50 | 75 | 0 |

¹⁾ If you plan to install a side-mounted option module to the drive, take the extra width needed on the right into account.

ACS580-01

| Ambient conditions | | | | | | | | | | | |
|---|--|---|--|--------------|----|-----------|-----|------------|-----|------------|----------|
| | Operation installed for stationary use | Storage in the protective package | Transportation in the protective package | | | | | | | | |
| Installation site altitude | 0 to 4000 m above sea level. ¹⁾ 0 to 2000 m above sea level. ²⁾ In altitudes 1000...4000 m above sea level, the derating is 1% for every 100 m. | – | – | | | | | | | | |
| Surrounding air temperature | -15 to +50 °C. 0 to -15 °C (no frost allowed). | -40 to +70 °C | -40 to +70 °C | | | | | | | | |
| Relative humidity ^{*)} | 5 to 95% | Max. 95% | Max. 95% | | | | | | | | |
| Contamination levels ^{**)} (IEC 60721-3-x) | IEC 60721-3-3:2002: Classification of environmental conditions – Part 3-3: Classification of groups of environmental parameters and their severities – Stationary use of weather protected locations. Chemical gases: Class 3C2. Solid particles: Class 3S2. (No conductive dust allowed). | According to IEC 60721-3-1: 1997 Chemical gases: Class 1C2 Solid particles: Class 1S3 (Packing must support this, otherwise 1s ²⁾) | According to IEC 60721-3-2:1997 Chemical gases: Class 2C2 Solid particles: Class 2S2 | | | | | | | | |
| Pollution degree (IEC/EN 61800-5-1) | Pollution degree 2 | – | – | | | | | | | | |
| Atmosphere pressure | 70 to 106 kPa, 0.7 to 1.05 atmospheres | 70 to 106 kPa, 0.7 to 1.05 atmospheres | 60 to 106 kPa, 0.6 to 1.05 atmospheres | | | | | | | | |
| Vibration (IEC 60068-2) | Max. 1 mm, (5 to 13.2 Hz), max. 7 m/s ² , (13.2 to 100 Hz) sinusoidal | – | – | | | | | | | | |
| Vibration (ISTA) | – | R1...R4 (ISTA 1A): Displacement, 25 mm peak to peak, 14200 vibratory impacts. R5...R9 (ISTA 3E): Random, overall Grms level of 0.52. | | | | | | | | | |
| Shock/Drop (ISTA) | Not allowed | R1...R4 (ISTA 1A): Drop, 6 faces, 3 edges and 1 corner. R5...R9 (ISTA 3E): Shock, incline impact: 1.1 m/s. Shock, rotational edge drop: 200 mm. | <table border="1"> <thead> <tr> <th>Weight range</th> <th>mm</th> </tr> </thead> <tbody> <tr> <td>0...10 kg</td> <td>760</td> </tr> <tr> <td>10...19 kg</td> <td>610</td> </tr> <tr> <td>19...28 kg</td> <td>460, 340</td> </tr> </tbody> </table> | Weight range | mm | 0...10 kg | 760 | 10...19 kg | 610 | 19...28 kg | 460, 340 |
| Weight range | mm | | | | | | | | | | |
| 0...10 kg | 760 | | | | | | | | | | |
| 10...19 kg | 610 | | | | | | | | | | |
| 19...28 kg | 460, 340 | | | | | | | | | | |

¹⁾ For neutral-grounded TN and TT systems and non-corner grounded IT systems. ²⁾ For corner-grounded TN, TT and IT systems.

^{*)} No condensation allowed. Maximum allowed relative humidity is 60 % in the presence of corrosive gases. ^{**)} No conductive dust allowed.

| Switching frequency derating | | | | | | | |
|---|------------|---------|-------|-------|-------|--------|--|
| Voltage (V) 380-480 | | | | | | | |
| Power range (kW) 0.75-250 | | | | | | | |
| Derating factor (k) for the minimum switching frequencies | | | | | | | |
| Type ACS580-01- | Frame size | 1.5 kHz | 2 kHz | 4 kHz | 8 kHz | 12 kHz | |
| 02A1-4...12A7-4 | R1 | – | 1 | 1 | 0.67 | 0.5 | |
| 014A-4...026A-4 | R2 | – | 1 | 1 | 0.65 | 0.48 | |
| 027A-4...046A-4 | R3 | – | 1 | 1 | 0.65 | 0.48 | |
| 052A-4...062A-4 | R4 | – | 1 | 1 | 0.82 | 0.64 | |
| 065A-4...073A-4 | R4 | – | 1 | 1 | 0.73 | 0.55 | |
| 078A-4...106A-4 | R5 | – | 1 | 1 | 0.71 | 0.57 | |
| 124A-4...145A-4 | R6 | 1 | 1 | 0.84 | 0.66 | 0.52 | |
| 156A-4...206A-4 | R7 | 1 | 1 | 0.89 | 0.71 | 0.53 | |
| 240A-4...293A-4 | R8 | 1 | 1 | 0.82 | 0.61 | 0.45 | |
| 361A-4...430A-4 | R9 | 1 | 1 | 0.79 | 0.58 | 0.43 | |

| Surrounding air temperature derating | | |
|--------------------------------------|--------------|---|
| Frame size | Temperature | Derating |
| R1...R9 | Up to +40 °C | No derating |
| R1...R9 | +40...+50 °C | Output current is decreased by 1% for every additional 1 °C |

| Altitude derating | |
|-------------------|---|
| Units | Derating |
| All variants | 0...1000 m no derating |
| All variants | 1000...4000 m above sea level, the derating is 1% for every 100 m |

Free space requirements

| Frame size | Vertical installation stand alone | | | Vertical installation side by side | | | Horizontal installation | | | |
|------------|-----------------------------------|----------------------|-----------------------|------------------------------------|--------------------------|-----------------|-------------------------|----------------------|------------------------|--------------------------|
| | Above IP21/IP55 (mm) | Below IP21/IP55 (mm) | Beside IP21/IP55 (mm) | Above (mm) | Below ¹⁾ (mm) | Between (mm) | Above IP21/IP55 (mm) | Below IP21/IP55 (mm) | Side up IP21/IP55 (mm) | Side down IP21/IP55 (mm) |
| R1 | 150/137 | 86/116 | 150 ¹⁾ | 200 ¹⁾ | 200 ¹⁾ | 0 ¹⁾ | 150/137 | 86/116 | 30 ¹⁾ | 200 ¹⁾ |
| R2 | 150/137 | 86/116 | 150 ¹⁾ | 200 ¹⁾ | 200 ¹⁾ | 0 ¹⁾ | 150/137 | 86/116 | 30 ¹⁾ | 200 ¹⁾ |
| R3 | 200 ¹⁾ | 53 ¹⁾ | 150 ¹⁾ | 200 ¹⁾ | 200 ¹⁾ | 0 ¹⁾ | 200 ¹⁾ | 53 ¹⁾ | 30 ¹⁾ | 200 ¹⁾ |
| R4 | 53 ¹⁾ | 200 ¹⁾ | 150 ¹⁾ | 200 ¹⁾ | 200 ¹⁾ | 0 ¹⁾ | 30 ¹⁾ | 200 ¹⁾ | 30 ¹⁾ | 200 ¹⁾ |
| R5 | 100 ¹⁾ | 200 ¹⁾ | 150 ¹⁾ | 200 ¹⁾ | 200 ¹⁾ | 0 ¹⁾ | 30 ¹⁾ | 200 ¹⁾ | 30 ¹⁾ | 200 ¹⁾ |
| R6 | 155 ¹⁾ | 300 ¹⁾ | 150 ¹⁾ | 200 ¹⁾ | 300 ¹⁾ | 0 ¹⁾ | – | – | – | – |
| R7 | 155 ¹⁾ | 300 ¹⁾ | 150 ¹⁾ | 200 ¹⁾ | 300 ¹⁾ | 0 ¹⁾ | – | – | – | – |
| R8 | 155 ¹⁾ | 300 ¹⁾ | 150 ¹⁾ | 200 ¹⁾ | 300 ¹⁾ | 0 ¹⁾ | – | – | – | – |
| R9 | 200 ¹⁾ | 300 ¹⁾ | 150 ¹⁾ | 200 ¹⁾ | 300 ¹⁾ | 0 ¹⁾ | – | – | – | – |

¹⁾ Applies to IP21 and IP55

Note 1: considering the original IP21 version Horizontal installation meets IP20 requirements only.

Note 2: considering the original IP55/type 12 version Horizontal installation meets IP21/type 1 requirements only.

ACS580-04

| Ambient conditions | | | |
|--|---|---|---|
| | Operation installed for stationary use | Storage in the protective package | Transportation in the protective package |
| Installation site altitude | 0 to 4000 m above sea level ¹⁾ 0 to 2000 m above sea level ²⁾ At altitudes from 1000 to 4000 m above sea level, the derating is 1% for every 100 m. | - | - |
| Air temperature | -15 to +55 °C (no frost allowed) | -40...+70 °C | -40...+70 °C |
| Relative humidity ^{*)} | 5 to 95% | Max. 95% | Max. 95% |
| Contamination levels (IEC 60721-3-3: 2002, IEC 60721-3-2:1997, IEC 60721-3-1:1997) | Chemical gases: Class 3C2 Solid particles: Class 3S2 (No conductive dust allowed) | Chemical gases: Class 1C2 Solid particles: Class 1S3 (No conductive dust allowed) | Chemical gases: Class 2C2 Solid particles: Class 2S2 (No conductive dust allowed) |
| Atmosphere pressure | 70 to 106 kPa 0.7 to 1.05 atmospheres | 70 to 106 kPa 0.7 to 1.05 atmospheres | 60 to 106 kPa, 0.6 to 1.05 atmospheres |
| Vibration (IEC 60068-2-6. Test Fc) | Max. 0.1 mm (10 to 57 Hz), max. 10 m/s ² (57 to 150 Hz) sinusoidal | Max. 1 mm (5 to 13.2 Hz), max. 7 m/s ² (13.2 to 100 Hz) sinusoidal | Max. 3.5 mm (2 to 9 Hz), max. 15 m/s ² (9 to 200 Hz) sinusoidal |
| Shock (IEC 60068-2-27) | Not allowed | Max. 100 m/s ² , 11 ms | Max. 100 m/s ² , 11 ms |
| Free fall | Not allowed | 100 mm for weight over 100 kg | 100 mm for weight over 100 kg |

¹⁾ For neutral-grounded TN and TT systems and non-corner grounded IT systems.

²⁾ For corner-grounded TN, TT and IT systems.

^{*)} No condensation allowed. Maximum allowed relative humidity is 60% in the presence of corrosive gases.

Switching frequency derating

Voltage (V) 380-480

Power range (kW) 250-500

Derating factor (k) for the minimum switching frequencies

| Type ACS580-04- | Frame size | 1 kHz | 2 kHz | 4 kHz | 8 kHz |
|-----------------|------------|-------|-------|-------|-------|
| 505A-4...650A-4 | R10 | 1 | 0.92 | 0.78 | 0.58 |
| 725A-4...880A-4 | R11 | 1 | 0.92 | 0.78 | 0.58 |

Surrounding air temperature derating

| Frame size | Temperature | Derating |
|------------|--------------|-------------------------|
| R10...R11 | Up to +40 °C | No derating |
| R10...R11 | +40...55 °C | 1% for every added 1 °C |

Altitude derating

| Units | Derating |
|--------------|---|
| All variants | 0...1000 m no derating |
| All variants | 1000...4000 m above sea level, the derating is 1 % for every 100 m |

Free space requirements

| Frame size | Front (mm) | Back ¹⁾ (mm) | On the sides (mm) |
|--------------|------------|-------------------------|-------------------|
| All variants | 20 | 20 | 0 |

¹⁾ Space from the back wall

ACS580-07

| Ambient conditions | | | |
|--|--|--|--|
| | Operation installed for stationary use | Storage in the protective package | Transportation in the protective package |
| Installation site altitude | 0 to 2000 m above sea level. For altitudes over 2000 m, contact ABB. At altitudes from 1000 to 2000 m above sea level, the derating is 1% for every 100 m. | – | – |
| Air temperature | -0 to +50 °C (no condensation allowed). Output derated in the range +40 ... +50 °C. | – | – |
| Relative humidity *) | 5 to 95% | Max. 95% | Max. 95% |
| Contamination levels | IEC/EN 60721-3-3:2002: Classification of environmental conditions – Part 3-3: Classification of groups of environmental parameters and their severities – Stationary use of weather protected locations Chemical gases: Class 3C2 Solid particles: Class 3S2 (No conductive dust allowed) | According to IEC 60721-3-1:1997 Chemical gases: Class 1C2 Solid particles: Class 1S3 (Packing must support this, otherwise 1S2) | EC 60721-3-2:1997 Chemical gases: Class 2C2 Solid particles: Class 2S2 |
| Atmosphere pressure | 70 to 106 kPa, 0.7 to 1.05 atmospheres | 70 to 106 kPa, 0.7 to 1.05 atmospheres | 60 to 106 kPa, 0.6 to 1.05 atmospheres |
| Vibration IEC 61800-5-1, IEC 60068-2-6:2007, EN 60068-2-6:2008 Environmental testing – Part 2: Tests – Test Fc: Vibration (sinusoidal) | IEC/EN 60721-3-3:2002 10...57 Hz: max. 0.075 mm amplitude 57...150 Hz: 1 g | IEC/EN 60721-3-1:1997 10...57 Hz: max. 0.075 mm amplitude 57...150 Hz: 1g | IEC/EN 60721-3-2:1997 2...9 Hz: max. 3.5 mm amplitude 9...20 Hz: 10 m/s ² |
| Shock IEC 60068-2-27:2008, EN 60068-2-27:2009 Environmental testing – Part 2-27: Tests – Test Ea and guidance: Shock | Not allowed | With packing max. 100 m/s ² , 11 ms | With packing max. 100 m/s ² , 11 ms |

*) No condensation allowed. Maximum allowed relative humidity is 60% in the presence of corrosive gases.

| Switching frequency derating | | | | | |
|------------------------------|------------|---------|---------|---------|---------|
| Voltage (V) 200-240, 380-480 | | | | | |
| Power range (kW) 250-500 | | | | | |
| Coefficient at 40 °C | | | | | |
| Type ACS580-07- | Frame size | 1.5 kHz | 2 kHz | 4 kHz | 8 kHz |
| 145A-4 | R6 | 1.00 | 0.97 | 0.84 | 0.66 |
| 169A-4...206A-4 | R7 | 1.00 | 0.98 | 0.89 | 0.71 |
| 246A-4...293A-4 | R8 | 1.00 | 0.96 | 0.82 | 0.61 |
| 246A-4...430A-4 | R9 | 1.00 *) | 0.95 *) | 0.79 *) | 0.58 *) |
| 505A-4...650A-A | R10 | 1.00 | 0.92 | 0.78 | 0.58 |
| 725A-4...880A-A | R11 | 1.00 | 0.92 | 0.78 | 0.58 |

*) Current derating for -0414A-4 and -0430A-4 at 35 °C.

| Surrounding air temperature derating | | | |
|--------------------------------------|------------|--------------|--|
| Type ACS580-07- | Frame size | Temperature | The rated output current is derated by |
| 145A-4...363A-4 | R6...R9 | Up to +40 °C | No derating |
| 430A-4 | R9 | Up to +35 °C | No derating |
| 145A-4...363A-4 | R6...R9 | +40...50 °C | 1 % for every added 1 °C |
| 430A-4 | R9 | +35...50 °C | 1 % for every added 1 °C |
| 505A-4...880A-A | R10...R11 | Up to +40 °C | No derating |
| 505A-4...880A-A | R10...R11 | +40...55 °C | 1 % for every added 1 °C |

| Altitude derating | |
|-------------------|---|
| Units | Derating |
| All variants | 0...1000 m no derating |
| All variants | 1000...2000 m above sea level, the derating is 1% for every 100 m |

| Free space requirements | | | |
|-------------------------|------------|------------|-------------------|
| Frame size | Front (mm) | Above (mm) | On the sides (mm) |
| All variants | 150 | 400 | – |

ACS880-01

| Ambient conditions | | | |
|--|--|---|--|
| | Operation installed for stationary use | Storage in the protective package | Transportation in the protective package |
| Installation site altitude | 0 to 4000 m above sea level ¹⁾ 0 to 2000 m above sea level ²⁾ At altitudes from 1000 to 4000 m above sea level, the derating is 1% for every 100 m. If ambient temperature is below 40 °C, the derating can be reduced by 1.5% for every 1 °C reduction in temperature. | - | - |
| Air temperature | -15 to +55 °C ³⁾ (no frost allowed) | -40...+70 °C | -40...+70 °C |
| Relative humidity ^{*)} | 5 to 95% | Max. 95% | Max. 95% |
| Contamination levels (IEC 60721-3-3: 2002, IEC 60721-3-2:1997, IEC 60721-3-1:1997) | Chemical gases: Class 3C2. For circuit boards in IP55 drives Class 3C3 and ANSI/ISA S71.04-1985 GX Solid particles: Class 3S2 (No conductive dust allowed) | Chemical gases: Class 1C2 Solid particles: Class 1S3 | Chemical gases: Class 2C2 Solid particles: Class 2S2 |
| Atmosphere pressure | 70 to 106 kPa 0.7 to 1.05 atmospheres | 70 to 106 kPa 0.7 to 1.05 atmospheres | 60 to 106 kPa, 0.6 to 1.05 atmospheres |
| Vibration (IEC 60068-2) | Max. 1 mm (5 to 13.2 Hz), max. 7 m/s ² (13.2 to 100 Hz) sinusoidal | Max. 1 mm (5 to 13.2 Hz), max. 7 m/s ² (13.2 to 100 Hz) sinusoidal | Max. 3.5 mm (2 to 9 Hz), max. 15 m/s ² (9 to 200 Hz) sinusoidal |
| Shock (IEC 60068-2-27) | Not allowed | Max. 100 m/s ² , 11 ms | Max. 100 m/s ² , 11 ms |
| Free fall | Not allowed | 100 mm for weight over 100 kg | 100 mm for weight over 100 kg |

¹⁾ For neutral-grounded TN and TT systems and non-corner grounded IT systems.

²⁾ For corner-grounded TN, TT and IT systems.

³⁾ For IP55 (UL Type 12) type -210A-7: -15 to +45 °C (5 to 113 °F). For IP55 (UL Type 12) types -0430A-3, -0414A-5 and -0271A-7: -15 to +35 °C (5 to 95 °F).

^{*)} No condensation allowed. Maximum allowed relative humidity is 60% in the presence of corrosive gases.

| Altitude derating | |
|-------------------|--|
| Units | Derating |
| All variants | 0...1000 m no derating |
| All variants | 1000...4000 m above sea level, the derating is 1% for every 100 m. If ambient temperature is below 40 °C, the derating can be reduced by 1.5% for every 1 °C. |

| Free space requirements | | | |
|-------------------------|------------|------------|---------------------------|
| Frame size | Front (mm) | Above (mm) | Bottom ¹⁾ (mm) |
| All variants | 0 | 200 | 300 |

¹⁾ When measured from the drive base without the cable entry box.

| Surrounding air temperature derating | | | |
|---|--|--|---|
| Type ACS880-01- | IP-frame | Temperature | The rated output current is derated by |
| All drives | IP21 (UL Type 1) drive types and other IP55 (UL Type 12) types than listed below | +40...55 °C | 1% for every added 1 °C |
| -274A-2, 293A-3, -260A-5, -302A-5 and -174A-7 | IP55 (UL Type 12) | +40...55 °C | 1% for every added 1 °C In the temperature range +45...55 °C, 2.5% for every added 1 °C |
| -240A-5 | IP55 (UL Type 12) | +40...55 °C | 1% for every added 1 °C In the temperature range +45...55 °C, 2.5% for every added 1 °C |
| -363A-3 and -361A-5 | IP55 (UL Type 12) | +40...55 °C | 1% for every added 1 °C In the temperature range +45...50 °C, 2.5% for every added 1 °C In the temperature range +50...55 °C, 5% for every added 1 °C |
| -210A-7 | IP55 (UL Type 12) | +40...55 °C | 3.5% for every added 1 °C The maximum temperature is 45 °C |
| -0430A-3, -0414A-5 and -0271A-7 | IP55 (UL Type 12) | The maximum ambient temperature is 35 °C | |

ACS880-04, ACS880-04XT

| Ambient conditions | | | |
|---|---|--|--|
| | Operation installed for stationary use | Storage in the protective package | Transportation in the protective package |
| Installation site altitude | 0 to 4000 m above sea level ²⁾ 0 to 2000 m above sea level ³⁾ At altitudes from 1000 to 4000 m above sea level, the derating is 1% for every 100 m. | – | – |
| Air temperature | -15 to +55 °C (no frost allowed) | -40...+70 °C | -40...+70 °C |
| Relative humidity ¹⁾ | 5 to 95% | Max. 95% | Max. 95% |
| Contamination levels ⁴⁾ | IEC/EN 60721-3-3:2002: Chemical gases: Class 3C2 Solid particles: Class 3S2 (No conductive dust allowed) | IEC 60721-3-1:1997: Chemical gases: Class 1C2 Solid particles: Class 1S3 (Packing must support this, otherwise 1S2) | IEC 60721-3-2:1997: Chemical gases: Class 2C2 Solid particles: Class 2S2 |
| Pollution degree | 2 | 2 | 2 |
| Atmosphere pressure | 70 to 106 kPa 0.7 to 1.05 atmospheres | 70 to 106 kPa 0.7 to 1.05 atmospheres | 60 to 106 kPa, 0.6 to 1.05 atmospheres |
| Vibration IEC 60068-2-6:2007, EN 60068-2-6:2008 Environmental testing – Part 2: Tests – Test Fc: Vibration (sinusoidal) | Max. 0.1 mm (10 to 57 Hz), max. 10 m/s ² (57 to 150 Hz) sinusoidal | Max. 7 m/s ² (13.2 to 100 Hz) sinusoidal | Max. 3.5 mm (2 to 9 Hz), max. 15 m/s ² (9 to 200 Hz) sinusoidal |
| Shock IEC 60068-2-27:2008, EN 60068-2-27:2009 Environmental testing – Part 2-27: Tests – Test Ea and guidance: Shock | Not allowed | With packing max. 100 m/s ² , 11 ms | With packing max. 100 m/s ² , 11 ms |
| Free fall | Not allowed | 100 mm for weight over 100 kg | 100 mm for weight over 100 kg |

¹⁾ No condensation allowed. Maximum allowed relative humidity is 60% in the presence of corrosive gases.

²⁾ For neutral-grounded TN and TT systems and non-corner grounded IT systems.

³⁾ For corner-grounded TN, TT and IT systems.

⁴⁾ C = Chemically active substances, S = Mechanically active substances.

| Altitude derating | |
|-------------------|---|
| Units | Derating |
| All variants | 0 to 1000 m no derating |
| All variants | 1000 to 4000 m above sea level, the derating is 1% for every 100 m. If ambient temperature is below 40 °C, the derating can be reduced by 1.5% for every 1 °C. |

| Surrounding air temperature derating | | | |
|--------------------------------------|------------|--------------|--|
| Type | Frame size | Temperature | The rated output current is derated by |
| All variants | R10 to R11 | Up to +40 °C | No derating |
| All variants | R10 to R11 | +40...55 °C | 1 % for every added 1 °C |

| Free space requirements | | | | |
|-------------------------|------------|-------------------------|------------|---------------------------|
| Frame size | Front (mm) | Back ¹⁾ (mm) | Above (mm) | Bottom ¹⁾ (mm) |
| All variants | 20 | 20 | 300 | 0 |

¹⁾ Space from the back wall

²⁾ When measured from the drive base without the cable entry box. If you install the drive module on its back, make sure that the hot cooling air that flows upwards from the module does not cause danger.

ACS880-04F, ACS880-04FXT

| Ambient conditions | | | |
|---|---|---|--|
| | Operation installed for stationary use | Storage in the protective package | Transportation in the protective package |
| Installation site altitude | 0 to 4000 m above sea level ²⁾ 0 to 2000 m above sea level ³⁾ | – | – |
| Air temperature | -15 to +40 °C (no frost allowed) | -40...+70 °C | -40...+70 °C |
| Relative humidity ¹⁾ | 5 to 95% | Max. 95% | Max. 95% |
| Contamination levels ⁴⁾ | IEC/EN 60721-3-3:2002: Chemical gases: Class 3C2 Solid particles: Class 3S2 (No conductive dust allowed) | IEC 60721-3-1:1997: Chemical gases: Class 1C2 Solid particles: Class 1S3 (packing must support this, otherwise 1S2) | IEC 60721-3-2:1997: Chemical gases: Class 2C2 Solid particles: Class 2S2 |
| Pollution degree | 2 | 2 | 2 |
| Atmosphere pressure | 70 to 106 kPa 0.7 to 1.05 atmospheres | 70 to 106 kPa 0.7 to 1.05 atmospheres | 60 to 106 kPa, 0.6 to 1.05 atmospheres |
| Vibration IEC 60068-2-6:2007, EN 60068-2-6:2008 | Max. 0.1 mm (10 to 57 Hz), max. 10 m/s ² (57 to 150 Hz) sinusoidal | Max. 1 mm (5 to 13.2 Hz), max. 7 m/s ² (13.2 to 100 Hz) sinusoidal | Max. 3.5 mm (2 to 9 Hz), max. 15 m/s ² (9 to 200 Hz) sinusoidal |
| Shock IEC 60068-2-27:2008, EN 60068-2-27:2009 | Not allowed | With packing max. 100 m/s ² , 11 ms | With packing max. 100 m/s ² , 11 ms |
| Free fall | Not allowed | 100 mm for weight over 100 kg | 100 mm for weight over 100 kg |

¹⁾ No condensation allowed. Maximum allowed relative humidity is 60% in the presence of corrosive gases.

²⁾ For neutral-grounded TN and TT systems and non-corner grounded IT systems.

³⁾ For corner-grounded TN, TT and IT systems.

⁴⁾ C = Chemically active substances, S = Mechanically active substances.

| Altitude derating | |
|-------------------|---|
| Units | Derating |
| All variants | 0 to 1000 m without derating |
| All variants | 1000 to 4000 m above sea level, the derating is 1% for every 100 m. Derating reduced by lower than 40 °C ambient temperature. |

| Free space requirements | | |
|--------------------------------|------------|-------------|
| ACS880-04F/04FXT ^{*)} | | |
| Frame size | Above (mm) | Bottom (mm) |
| R11 | 200 | 200 |

^{*)} The modules can be installed side by side.

| Surrounding air temperature derating | | | |
|--------------------------------------|------------|---------------|--|
| Type | Frame size | Temperature | The rated output current is derated by |
| Air-cooled | R11 | +40 to +55 °C | 1 % for every added 1 °C |

ACS880-07

| Ambient conditions | | | |
|--|---|---|---|
| | Operation installed for stationary use | Storage in the protective package | Transportation in the protective package |
| Installation site altitude | 0...2000 m above sea level. For altitudes over 2000 m, contact ABB. Output derated above 1000 m. | - | - |
| Air temperature | 0...+40 °C (no condensation allowed). Output derated in the range +40...+50 °C | -40 to +70 °C | -40 to +70 °C |
| Relative humidity *) | Max. 95% | Max. 95% | Max. 95% |
| Contamination levels | IEC/EN 60721-3-3:2002: Classification of environmental conditions- Part 3-3: Classification of groups of environmental parameters and their severities – Stationary use of weather protected locations Chemical gases: Class 3C2 Solid particles: Class 3S2 (3S1 with IP20). No conductive dust allowed. | IEC 60721-3-1:1997: Chemical gases: Class 1C2 Solid particles: Class 1S3 (packing must support this, otherwise 1S2) | IEC 60721-3-2:1997: Chemical gases: Class 2C2 Solid particles: Class 2S2 |
| Pollution degree | 2 | 2 | 2 |
| Atmosphere pressure | 70 to 106 kPa, 0.7 to 1.05 atmospheres | 70 to 106 kPa, 0.7 to 1.05 atmospheres | 60 to 106 kPa, 0.6 to 1.05 atmospheres |
| Vibration IEC/EN 61800-5-1, IEC 60068-2-6:2007, EN 60068-2-6:2008 Environmental testing – Part 2: Tests – Test Fc: Vibration (sinusoidal) | IEC/EN 60721-3-3:2002 10...57 Hz: max. 0.075 mm amplitude 57...150 Hz: 1 g Units with marine construction (option +C121): Max. 1 mm (5...13.2 Hz), max. 0.7 g (13.2...100 Hz) sinusoidal | IEC/EN 60721-3-1:1997 10...57 Hz: max. 0.075 mm amplitude 57...150 Hz: 1 g | IEC/EN 60721-3-2:1997 2...9 Hz: max. 3.5 mm amplitude 9...200 Hz: 10 m/s ² |
| Shock IEC 60068-2-27:2008, EN 60068-2-27:2009 Environmental testing – Part 2-27: Tests – Test Ea and guidance: Shock | Not allowed | With packing max. 100 m/s ² , 11 ms | With packing max. 100 m/s ² , 11 ms |

*) No condensation allowed. Maximum allowed relative humidity is 60% in the presence of corrosive gases.

| Altitude derating | |
|-------------------|---|
| Units | Derating |
| All variants | 0...1000 m no derating |
| All variants | 1000...4000 m above sea level, the derating is 1% for every 100 m. If ambient temperature is below 40 °C, the derating can be reduced by 1.5% for every 1 °C. |

| Surrounding air temperature derating | | | |
|--------------------------------------|------------|--------------|--|
| Type | Frame size | Temperature | The rated output current is derated by |
| All variants | R6...R11 | Up to +40 °C | No derating |
| All variants | R6...R11 | +40...50 °C | 1 % for every added 1 °C |

| Free space requirements | | | |
|-------------------------|----------------|-----------|---------------|
| Frame size | Front **) (mm) | Side (mm) | Above *) (mm) |
| R6...R11 | 150 | - | 400 |

*) Measured from the base plate of the cabinet top.
**) For air circulation. To open the door, see picture below.

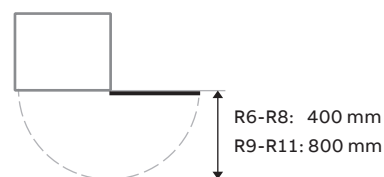

ACS880-11, ACS880-31

| Ambient conditions | | | |
|------------------------------------|--|--|--|
| | Operation installed for stationary use | Storage in the protective package | Transportation in the protective package |
| Installation site altitude | 0 to 4000 m above sea level ¹⁾ 0 to 2000 m above sea level ²⁾ Output derated above 1000 m | - | - |
| Air temperature | -15 to +55 °C (no frost allowed) | -40 to +70 °C | -40 to +70 °C |
| Relative humidity ³⁾ | 5 to 95% | Max. 95% | Max. 95% |
| Contamination levels ^{*)} | IEC 60721-3-3:2002: Chemical gases: Class 3C2 Solid particles: Class 3S2 (No conductive dust allowed) | IEC 60721-3-1: 1997: Chemical gases: Class 1C2 Solid particles: Class 1S3 (packing must support this, otherwise 1S2) | IEC 60721-3-2:1997: Chemical gases: Class 2C2 Solid particles: Class 2S2 |
| Pollution degree | 2 | - | - |
| Atmosphere pressure | 70 to 106 kPa, 0.7 to 1.05 atmospheres | 70 to 106 kPa, 0.7 to 1.05 atmospheres | 60 to 106 kPa, 0.6 to 1.05 atmospheres |
| Vibration IEC 60068-2-6:2007 | 10 to 150 Hz Amplitude ±0.075 mm, 10 to 57.56 Hz Constant peak acceleration 10 m/s ² , 57.56 to 150 Hz | - | - |
| Vibration (ISTA) | - | R3: Displacement, 25 mm peak to peak, 14200 vibratory impacts. R6, R8: (ISTA 3E): Random, overall Grms level of 0.54 | R3: Displacement, 25 mm peak to peak, 14200 vibratory impacts. R6, R8: (ISTA 3E): Random, overall Grms level of 0.54 |
| Shock/Drop (ISTA) | Not allowed | R3 (ISTA 1A): Drop, 6 faces, 3 edges and 1 corner, 460 mm R6, R8 (ISTA 3E): Shock, incline impact: 1.2 m/s Shock, rotational edge drop: 230 mm | R3 (ISTA 1A): Drop, 6 faces, 3 edges and 1 corner, 460 mm R6, R8 (ISTA 3E): Shock, incline impact: 1.2 m/s Shock, rotational edge drop: 230 mm |

*) C = Chemically active substances, S = Mechanically active substances.

¹⁾ For neutral-grounded TN and TT systems and non-corner grounded IT systems.

²⁾ For corner-grounded TN, TT and IT systems.

³⁾ No condensation allowed. Maximum allowed relative humidity is 60% in the presence of corrosive gases.

| Altitude derating | |
|-------------------|---|
| Units | Derating |
| All variants | 1000...4000 m above sea level, the derating is 1% for every 100 m. Derating reduced by lower than 40 °C ambient. |

| Free space requirements | | | |
|------------------------------------|------------|------------|-----------|
| ACS880-11, ACS880-31 ^{*)} | | | |
| Frame size | Above (mm) | Below (mm) | Side (mm) |
| All variants | 200 | 300 | 0 |

*) Vertical installation. Do not install the drive upside down.

The drive must be installed on the wall. There are three alternative ways to install it:

- Vertically alone. Do not install the drive upside down.
- Vertically side by side.
- Horizontally alone, IP21 only. See hardware manual.

| Surrounding air temperature derating | | | |
|--------------------------------------|-------------------|---------------|---|
| Type | IP-frame | Temperature | The rated output current is derated by |
| All drives | IP21 (UL Type 1) | Up to +40 °C | No derating |
| All drives | IP21 (UL Type 1) | +40 to +55 °C | Derate 1% for every 1 °C |
| -087A-3+B056 -077A-5+B056 | IP55 (UL Type 12) | Up to +40 °C | No derating |
| -087A-3+B056 -077A-5+B056 | IP55 (UL Type 12) | +40 to +55 °C | Derate 1% for every 1 °C up to 45 °C: Derate 2% for every 1 °C up to 55 °C |
| -206A-3+B056 -180A-5+B056 | IP55 (UL Type 12) | Up to +40 °C | No derating |
| -206A-3+B056 -180A-5+B056 | IP55 (UL Type 12) | +40 to +55 °C | Derate 1.5% for every 1 °C |

Note: For ambient temperatures above +40 °C, the power cables must be rated for 90 °C minimum.

ACS880-14, ACS880-34

| Ambient conditions | | | |
|---|--|---|--|
| | Operation installed for stationary use | Storage in the protective package | Transportation in the protective package |
| Installation site altitude | 0 to 4000 m above sea level ¹⁾ | – | – |
| Air temperature | -15 to +55 °C (no frost allowed) | -40 to +70 °C | -40 to +70 °C |
| Relative humidity ²⁾ | 5 to 95% | Max. 95% | Max. 95% |
| Contamination levels ^{*)} | IEC/EN 60721-3-3:2002 Chemical gases: Class 3C2 Solid particles: Class 3S2 No conductive dust allowed | IEC 60721-3-1:1997: Chemical gases: Class 1C2 Solid particles: Class 1S3 (packing must support this, otherwise 1S2) | IEC 60721-3-2:1997: Chemical gases: Class 2C2 Solid particles: Class 2S2 |
| Pollution degree (IEC/EN 61800-5-1) | 2 | 2 | 2 |
| Atmosphere pressure | 70 to 106 kPa, 0.7 to 1.05 atmospheres | 70 to 106 kPa, 0.7 to 1.05 atmospheres | 60 to 106 kPa, 0.6 to 1.05 atmospheres |
| Vibration IEC 60068-2-6:2007, EN 60068-2-6:2008 Environmental testing – Part 2: Tests – Test Fc: Vibration (sinusoidal) | Max. 0.1 mm (10 to 57 Hz), max. 10 m/s ² (57 to 150 Hz) sinusoidal | Max. 1 mm (5 to 13.2 Hz), max. 7 m/s ² (13.2 to 100 Hz) sinusoidal | Max. 3.5 mm (2 to 9 Hz), max. 15 m/s ² (9 to 200 Hz) sinusoidal |
| Shock IEC 60068-2-27:2008, EN 60068-2-27:2009 Environmental testing – Part 2-27: Tests – Test Ea and guidance: Shock | Not allowed | With packing max. 100 m/s ² , 11 ms | With packing max. 100 m/s ² , 11 ms |
| Free fall | Not allowed | 100 mm for weight over 100 kg | 100 mm for weight over 100 kg |

*) C = Chemically active substances, S = Mechanically active substances.

¹⁾ For neutral-grounded TN and TT systems and ungrounded IT network systems.

²⁾ No condensation allowed. Maximum allowed relative humidity is 60% in the presence of corrosive gases.

| Altitude derating | |
|-------------------|---|
| Units | Derating |
| All variants | 0 to 1000 m no derating |
| All variants | 1000 to 4000 m above sea level, the derating is 1% for every 100 m. If ambient temperature is below 40 °C, the derating can be reduced by 1.5% for every 1 °C reduction in temperature. |

| Surrounding air temperature derating | | | |
|--------------------------------------|------------|--------------|--|
| Type | Frame size | Temperature | The rated output current is derated by |
| All variants | R11 | Up to +40 °C | No derating |
| All variants | R11 | +40...55 °C | 1 % for every added 1 °C |

| Free space requirements | | | | |
|-------------------------|------------|-----------|-----------|------------|
| ACS880-14, ACS880-34 | | | | |
| Frame size | Above (mm) | Side (mm) | Back (mm) | Front (mm) |
| All variants | 350 | 0 | 20 | 20 |

The module can be installed in a cabinet with the following dimensions:
width 800 mm, depth 600 mm, height 2000 mm.

ACS880-17, ACS880-37

| Ambient conditions | | | |
|--|---|---|---|
| | Operation installed for stationary use | Storage in the protective package | Transportation in the protective package |
| Installation site altitude | 0 to 4000 m above sea level ¹⁾ 0 to 2000 m above sea level ²⁾ Output derated above 1000 m | – | – |
| Air temperature | 0 to +40 °C (no condensation allowed) | -40 to +70 °C | -40 to +70 °C |
| Relative humidity ³⁾ | Max. 95% | Max. 95% | Max. 95% |
| Contamination levels ^{*)} | IEC/EN 60721-3-3:2002: Chemical gases: Class 3C2 Solid particles: Class 3S2 (3S1 with IP20). No conductive dust allowed. | IEC 60721-3-1: 1997: Chemical gases: Class 1C2 Solid particles: Class 1S3 (packing must support this, otherwise 1S2) | IEC 60721-3-2: 1997: Chemical gases: Class 2C2 Solid particles: Class 2S2 |
| Pollution degree | 2 | – | – |
| Atmosphere pressure | 70 to 106 kPa, 0.7 to 1.05 atmospheres | 70 to 106 kPa, 0.7 to 1.05 atmospheres | 60 to 106 kPa, 0.6 to 1.05 atmospheres |
| Vibration IEC/EN 61800-5-1, IEC 60068-2-6:2007, EN 60068-2-6:2008 Environmental testing – Part 2: Tests – Test Fc: Vibration (sinusoidal) | 10 to 150 Hz Amplitude ±0.075 mm, 10 to 57.56 Hz Constant peak acceleration 10 m/s ² , 57.56 to 150 Hz | – | – |
| Shock IEC 60068-2-27:2008, EN 60068-2-27:2009 Environmental testing – Part 2-27: Tests – Test Ea and guidance: Shock | Not allowed | With packing max. 100 m/s ² 11ms | With packing max. 100 m/s ² 11ms |

*) C = Chemically active substances, S = Mechanically active substances.

¹⁾ For neutral-grounded TN and TT systems and non-corner grounded IT systems.

²⁾ For corner-grounded TN, TT and IT systems.

³⁾ No condensation allowed. Maximum allowed relative humidity is 60% in the presence of corrosive gases.

| Altitude derating | |
|-------------------|---|
| Units | Derating |
| R8, R11 | 1000 to 2000 m above sea level, the output current derating is 1 percentage point for every added 100 m. If surrounding air temperature is below +40 °C, the derating can be reduced by 1.5 % points for every 1 °C reduction in temperature. |
| R8, R11 | Alltitudes above 2000 m contact ABB |

| Surrounding air temperature derating | | |
|--------------------------------------|---------------|--|
| Type | Temperature | The rated output current is derated by |
| R8, R11 | +40 to +50 °C | 1 % for every added 1 °C |

| Free space requirements | | | |
|-------------------------|------------|-----------|--------------------------|
| ACS880-17, ACS880-37 | | | |
| Frame size | Front (mm) | Side (mm) | Above ^{*)} (mm) |
| All variants | 150 | – | 400 |

*) Measured from the base plate of the cabinet top.

- The cabinet can be installed with its back against a wall, or back-to-back with another unit.
- Leave some space at the side where the cabinet outmost hinges are to allow the doors to open sufficiently. The doors must open 120° to allow supply or inverter module replacement.

Brake chopper and resistor with suggestion for type code

ACS380

Voltage (V) 1~200-480, 3~380-480

Power range (kW) 1~0.25-2.2, 3~0.25-22

| Type designation | Frame size | Internal brake chopper | | | | Example brake resistor(s) |
|---|------------|------------------------|--------------------|--------------------|---------------------|--|
| | | P_{BRcont} (kW) | R_{min} (ohm) | R_{max} (ohm) | P_{BRmax} (kW) | Reference resistor types Danotherm |
| 1-phase $U_N = 200...240$ V | | | | | | |
| ACS380-04xx-02A4-1 | R0 | 0.25 | 32.5 | 468 | 0.38 | CBH 360 C T 406 210R or CAR 200 D T 406 210R |
| ACS380-04xx-03A7-1 | R0 | 0.37 | 32.5 | 316 | 0.56 | |
| ACS380-04xx-04A8-1 | R1 | 0.55 | 32.5 | 213 | 0.83 | CBR-V 330 D T 406 78R UL |
| ACS380-04xx-06A9-1 | R1 | 0.75 | 32.5 | 145 | 1.1 | |
| ACS380-04xx-07A8-1 | R1 | 1.1 | 32.5 | 96.5 | 1.7 | CBR-V 560 D HT 406 39R UL |
| ACS380-04xx-09A8-1 | R2 | 1.5 | 32.5 | 69.9 | 2.3 | |
| ACS380-04xx-12A2-1 | R2 | 2.2 | 19.5 | 47.1 | 3.3 | |
| 3-phase $U_N = 380...480$ V | | | | | | |
| ACS380-04xx-01A8-4 | R0 | 0.37 | 99 | 933 | 0.56 | CBH 360 C T 406 210R or CAR 200 D T 406 210R |
| ACS380-04xx-02A6-4 | R1 | 0.55 | 99 | 628 | 0.83 | |
| ACS380-04xx-03A3-4 | R1 | 0.75 | 99 | 428 | 1.13 | CBR-V 330 D T 406 78R UL |
| ACS380-04xx-04A0-4 | R1 | 1.1 | 99 | 285 | 1.65 | |
| ACS380-04xx-05A6-4 | R1 | 1.5 | 99 | 206 | 2.25 | CBR-V 560 D HT 406 39R UL |
| ACS380-04xx-07A2-4 | R1 | 2.2 | 53 | 139 | 3.3 | |
| ACS380-04xx-09A4-4 | R1 | 3 | 53 | 102 | 4.5 | CBT-H 560 D HT 406 19R |
| ACS380-04xx-12A6-4 | R2 | 4 | 32 | 76 | 6.0 | |
| ACS380-04xx-17A0-4 | R3 | 5.5 | 32 | 54 | 8.25 | CBT-H 760 D HT 406 16R |
| ACS380-04xx-25A0-4 | R3 | 7.5 | 23 | 39 | 11.25 | |
| ACS380-04xx-032A-4 | R4 | 11 | 6 | 29 | 17 | |
| ACS380-04xx-038A-4 | R4 | 15 | 6 | 24 | 23 | |
| ACS380-04xx-045A-4 | R4 | 18.5 | 6 | 20 | 28 | |
| ACS380-04xx-050A-4 | R4 | 22 | 6 | 20 | 33.0 | |

P_{BRmax} = The maximum braking capacity of the drive 1/10min ($P_{BRcont} * 150\%$), must exceed the desired braking power.

P_{BRcont} = The maximum braking capacity of the drive, must exceed the desired braking power.

ACS480

Voltage (V) 1~200-480, 3~380-480

Power range (kW) 1~0.25-2.2, 3~0.25-22

| Type designation | Frame size | Internal brake chopper | | | | Example brake resistor(s) | |
|---|------------|------------------------|--------------------|--------------------|---------------------|---------------------------|--|
| | | P_{BRcont} (kW) | R_{min} (ohm) | R_{max} (ohm) | P_{BRmax} (kW) | Reference resistor types | |
| | | | | | | | Danotherm |
| 3-phase $U_N = 380...480$ V | | | | | | | |
| ACS480-04-02A7-4 | R1 | 0.55 | 99 | 628 | 0.83 | | |
| ACS480-04-03A4-4 | R1 | 0.75 | 99 | 428 | 1.13 | | CBH 360 C T 406 210R or CAR 200 D T 406 210R |
| ACS480-04-04A1-4 | R1 | 1.1 | 99 | 285 | 1.65 | | |
| ACS480-04-05A7-4 | R1 | 1.5 | 99 | 206 | 2.25 | | |
| ACS480-04-07A3-4 | R1 | 2.2 | 53 | 139 | 3.3 | | |
| ACS480-04-09A5-4 | R1 | 3 | 53 | 102 | 4.5 | | CBR-V 330 D T 406 78R UL |
| ACS480-04-12A7-4 | R2 | 4 | 32 | 76 | 6.0 | | |
| ACS480-04-018A-4 | R3 | 5.5 | 32 | 54 | 8.25 | | CBR-V 560 D HT 406 39R UL |
| ACS480-04-026A-4 | R3 | 7.5 | 23 | 39 | 11.25 | | |
| ACS480-04-033A-4 | R4 | 11 | 6 | 29 | 17 | | CBT-H 560 D HT 406 19R |
| ACS480-04-039A-4 | R4 | 15 | 6 | 24 | 23 | | |
| ACS480-04-046A-4 | R4 | 18.5 | 6 | 20 | 28 | | CBT-H 760 D HT 406 16R |
| ACS480-04-050A-4 | R4 | 22 | 6 | 20 | 33 | | |

P_{BRmax} = The maximum braking capacity of the drive 1/10min ($P_{BRcont} * 150\%$), must exceed the desired braking power.

P_{BRcont} = The maximum braking capacity of the drive, must exceed the desired braking power.

ACS580-01

Voltage (V) 380-480

Power range (kW) 0.75-250

| Type designation | Frame size | Brake chopper type | Brake chopper | | | Example brake resistor(s) Reference resistor types |
|---|------------|--------------------|--------------------|--------------------|---------------------|---|
| | | | R_{min} (ohm) | R_{max} (ohm) | P_{BRmax} (kW) | |
| 3-phase $U_N = 230 V$ | | | | | | |
| ACS580-01-04A7-2 | R1 | Internal | 25 | 205 | 0.7 | Danotherm: CBR-V 330 D T 406 78R UL |
| ACS580-01-06A7-2 | R1 | Internal | 25 | 130 | 1.1 | Danotherm: CBR-V 330 D T 406 78R UL |
| ACS580-01-07A6-2 | R1 | Internal | 25 | 95 | 1.5 | Danotherm: CBR-V 560 D HT 406 39R UL |
| ACS580-01-012A-2 | R1 | Internal | 25 | 48 | 3 | Danotherm: CBR-V 560 D HT 406 39R UL |
| ACS580-01-018A-2 | R1 | Internal | 25 | 35 | 4.1 | - |
| ACS580-01-025A-2 | R2 | Internal | 14 | 26 | 5.4 | Danotherm: CBT-H 560 D HT 406 19R |
| ACS580-01-032A-2 | R2 | Internal | 14 | 19 | 7.4 | Danotherm: CBT-H 760 D HT 406 16R |
| ACS580-01-047A-2 | R3 | Internal | 6 | 13 | 11 | SAFUR90F575 |
| ACS580-01-060A-2 | R3 | Internal | 6 | 9 | 16 | SAFUR90F575 |
| ACS580-01-076A-2 | R4 | NBRA-658 | 2.6 | 7 | 21 | SAFUR125F500 |
| ACS580-01-089A-2 | R5 | NBRA-658 | 2 | 5.6 | 26 | SAFUR125F500 |
| ACS580-01-115A-2 | R5 | NBRA-658 | 2 | 4.7 | 31 | SAFUR125F500 |
| ACS580-01-144A-2 | R6 | NBRA-658 | 2 | 3.4 | 43 | SAFUR200F500 |
| ACS580-01-171A-2 | R7 | NBRA-658 | 1.3 | 2.8 | 53 | SAFUR200F500 |
| ACS580-01-213A-2 | R7 | NBRA-658 | 1.3 | 2.3 | 64 | 2xSAFUR210F575 |
| ACS580-01-276A-2 | R8 | NBRA-658 | 0.9 | 1.9 | 78 | 2xSAFUR210F575 |
| 3-phase $U_N = 400 V$ | | | | | | |
| ACS580-01-02A7-4 | R1 | Built-in | 52 | 864 | 0.6 | Danotherm: CBH 360 C T 406 210R |
| ACS580-01-03A4-4 | R1 | Built-in | 52 | 582 | 0.9 | Danotherm: CBH 360 C T 406 210R |
| ACS580-01-04A1-4 | R1 | Built-in | 52 | 392 | 1.4 | Danotherm: CBH 360 C T 406 210R |
| ACS580-01-05A7-4 | R1 | Built-in | 52 | 279 | 2 | Danotherm: CBH 360 C T 406 210R |
| ACS580-01-07A3-4 | R1 | Built-in | 52 | 191 | 2.9 | Danotherm: CBR-V 330 D T 406 78R UL |
| ACS580-01-09A5-4 | R1 | Built-in | 52 | 140 | 3.9 | Danotherm: CBR-V 330 D T 406 78R UL |
| ACS580-01-12A7-4 | R1 | Built-in | 52 | 104 | 5.3 | Danotherm: CBR-V 330 D T 406 78R UL |
| ACS580-01-018A-4 | R2 | Built-in | 31 | 75 | 7.3 | Danotherm: CBR-V 560 D HT 406 39R UL |
| ACS580-01-026A-4 | R2 | Built-in | 22 | 52 | 10 | Danotherm: CBR-V 560 D HT 406 39R UL |
| ACS580-01-033A-4 | R3 | Built-in | 16 | 37 | 15 | Danotherm: CBT-H 560 D HT 406 19R |
| ACS580-01-039A-4 | R3 | Built-in | 10 | 27 | 20 | Danotherm: CBT-H 760 D HT 406 16R |
| ACS580-01-046A-4 | R3 | Built-in | 10 | 22 | 25 | Danotherm: CBT-H 760 D HT 406 16R |
| ACS580-01-062A-4 | R4 | ACS-BRK-D | 7.8 | 18.1 | 30 | Built in with the brake chopper |
| ACS580-01-073A-4 | R4 | ACS-BRK-D | 7.8 | 13.1 | 42 | Built in with the brake chopper |
| ACS580-01-088A-4 | R5 | ACS-BRK-D | 7.8 | 10.7 | 51 | Built in with the brake chopper |
| ACS580-01-106A-4 | R5 | NBRA-658 | 1.3 | 8.7 | 63 | SAFUR125F500 |
| ACS580-01-145A-4 | R6 | NBRA-658 | 1.3 | 7.1 | 77 | SAFUR125F500 |
| ACS580-01-169A-4 | R7 | NBRA-658 | 1.3 | 5.2 | 105 | SAFUR200F500 |
| ACS580-01-206A-4 | R7 | NBRA-658 | 1.3 | 4.3 | 126 | SAFUR200F500 |
| ACS580-01-246A-4 | R8 | NBRA-658 | 1.3 | 3.5 | 156 | 2xSAFUR125F500 |
| ACS580-01-293A-4 | R8 | NBRA-658 | 1.3 | 2.9 | 187 | 2xSAFUR210F575 |
| ACS580-01-363A-4 | R9 | NBRA-659 | 0.7 | 2.4 | 227 | 2xSAFUR200F500 |
| ACS580-01-363A-4 | R9 | NBRA-659 | 0.7 | 1.9 | 284 | 2xSAFUR200F500 |

¹⁾ Other resistors can be used if they meet the minimum resistance value and required power values.

R_{min} = Minimum allowed brake resistor that can be connected to the brake chopper.

R_{max} = Maximum allowed brake resistor that allows PBRmax.

P_{BRmax} = Maximum braking capacity of the drive, must exceed the desired braking power.

Note 1: R1...R3 built-in integrated brake chopper, R4...R9 external chopper is needed.

ACS880-01

Voltage (V) 208-240, 380-415, 380-500, 525-690

Power range (kW) 0.55-250

| Type designation | Frame size | Example brake resistor(s) | | | | | |
|---------------------------------|------------|---------------------------|--------------------|--------------|---------------|---------------------|--------------------------|
| | | P_{BRcont} (kW) | R_{min} (ohm) | R (ohm) | E_r (kJ) | P_{rcont} (kW) | Reference resistor types |
| $U_N = 230 V$ | | | | | | | |
| ACS880-01-04A6-2 | R1 | 0.75 | 65 | 80 | 40 | 0.14 | JBR-03 |
| ACS880-01-06A6-2 | R1 | 1.1 | 65 | 80 | 40 | 0.14 | JBR-03 |
| ACS880-01-07A5-2 | R1 | 1.5 | 65 | 80 | 40 | 0.14 | JBR-03 |
| ACS880-01-10A6-2 | R1 | 2.2 | 65 | 80 | 40 | 0.14 | JBR-03 |
| ACS880-01-16A8-2 | R2 | 4 | 18 | 22 | 420 | 2 | SACE15RE22 |
| ACS880-01-24A3-2 | R2 | 5.5 | 18 | 22 | 420 | 2 | SACE15RE22 |
| ACS880-01-031A-2 | R3 | 7.5 | 13 | 13 | 435 | 2 | SACE15RE13 |
| ACS880-01-046A-2 | R4 | 11 | 12 | 13 | 435 | 2 | SACE15RE13 |
| ACS880-01-061A-2 | R4 | 11 | 12 | 13 | 435 | 2 | SACE15RE13 |
| ACS880-01-075A-2+D150 | R5 | 18.5 | 6 | 8 | 1800 | 4.5 | SAFUR90F575 |
| ACS880-01-087A-2+D150 | R5 | 22 | 6 | 8 | 1800 | 4.5 | SAFUR90F575 |
| ACS880-01-115A-2+D150 | R6 | 30 | 3.5 | 4 | 3600 | 9 | SAFUR125F500 |
| ACS880-01-145A-2+D150 | R6 | 37 | 3.5 | 4 | 3600 | 9 | SAFUR125F500 |
| ACS880-01-170A-2+D150 | R7 | 45 | 2.4 | 2.7 | 5400 | 13.5 | SAFUR125F500 |
| ACS880-01-206A-2+D150 | R7 | 55 | 2.4 | 2.7 | 5400 | 13.5 | SAFUR125F500 |
| ACS880-01-274A-2+D150 | R8 | 75 | 1.8 | 2.7 | 5400 | 13.5 | SAFUR125F500 |
| $U_N = 400 V$ | | | | | | | |
| ACS880-01-02A4-3 | R1 | - | 78 | 80 | 40 | 0.14 | JBR-03 |
| ACS880-01-03A3-3 | R1 | 1.1 | 78 | 80 | 40 | 0.14 | JBR-03 |
| ACS880-01-04A0-3 | R1 | 1.5 | 78 | 80 | 40 | 0.14 | JBR-03 |
| ACS880-01-05A6-3 | R1 | 2.2 | 78 | 80 | 40 | 0.14 | JBR-03 |
| ACS880-01-07A2-3 | R1 | 3 | 78 | 80 | 40 | 0.14 | JBR-03 |
| ACS880-01-09A4-3 | R1 | 4 | 78 | 80 | 40 | 0.14 | JBR-03 |
| ACS880-01-12A6-3 | R1 | 5.5 | 78 | 80 | 40 | 0.14 | JBR-03 |
| ACS880-01-017A-3 | R2 | 7.5 | 39 | 44 | 210 | 1 | SACE08RE44 |
| ACS880-01-025A-3 | R2 | 11 | 39 | 44 | 210 | 1 | SACE08RE44 |
| ACS880-01-032A-3 | R3 | 15 | 19 | 22 | 420 | 2 | SACE15RE22 |
| ACS880-01-038A-3 | R3 | 18.5 | 19 | 22 | 420 | 2 | SACE15RE22 |
| ACS880-01-045A-3 | R4 | 22 | 13 | 13 | 435 | 2 | SACE15RE13 |
| ACS880-01-061A-3 | R4 | 22 | 13 | 13 | 435 | 2 | SACE15RE13 |
| ACS880-01-072A-3+D150 | R5 | 37 | 8 | 8 | 1800 | 4.5 | SAFUR90F575 |
| ACS880-01-087A-3+D150 | R5 | 45 | 8 | 8 | 1800 | 4.5 | SAFUR90F575 |
| ACS880-01-105A-3+D150 | R6 | 55 | 5.4 | 6 | 2400 | 6 | SAFUR80F500 |
| ACS880-01-145A-3+D150 | R6 | 75 | 5.4 | 6 | 2400 | 6 | SAFUR80F500 |
| ACS880-01-169A-3+D150 | R7 | 90 | 3.3 | 4 | 3600 | 9 | SAFUR125F500 |
| ACS880-01-206A-3+D150 | R7 | 110 | 3.3 | 4 | 3600 | 9 | SAFUR125F500 |
| ACS880-01-246A-3+D150 | R8 | 132 | 2.3 | 2.7 | 5400 | 13.5 | SAFUR200F500 |
| ACS880-01-293A-3+D150 | R8 | 132 | 2.3 | 2.7 | 5400 | 13.5 | SAFUR200F500 |
| ACS880-01-363A-3+D150 | R9 | 160 | 2 | 2.7 | 5400 | 13.5 | SAFUR200F500 |
| ACS880-01-430A-3+D150 | R9 | 160 | 2 | 2.7 | 5400 | 13.5 | SAFUR200F500 |

P_{BRcont} = The drive (drive and chopper) withstands this continuous braking power.
Braking is considered continuous if braking time exceeds 30 seconds.

R_{min} = The minimum allowed resistance of the brake resistor.

R = Resistance of the listed resistor.

E_r = Short energy pulse that the resistor assembly withstands every 400 seconds.

This energy will heat the resistor element from 40°C (104°F) to the maximum allowable temperature.

P_{rcont} = Continuous power (heat) dissipation of the resistor when placed correctly. Energy ER dissipates in 400 seconds.

ACS880-01

Voltage (V) 208-240, 380-415, 380-500, 525-690

Power range (kW) 0.55-250

| Type designation | Frame size | Example brake resistor(s) | | | | | |
|---------------------------------|------------|---------------------------|--------------------|--------------|---------------|---------------------|--------------------------|
| | | P_{BRcont} (kW) | R_{min} (ohm) | R (ohm) | E_f (kJ) | P_{rcont} (kW) | Reference resistor types |
| $U_N = 500 V$ | | | | | | | |
| ACS880-01-02A1-5 | R1 | 0.75 | 78 | 80 | 40 | 0.14 | JBR-03 |
| ACS880-01-03A0-5 | R1 | 1.1 | 78 | 80 | 40 | 0.14 | JBR-03 |
| ACS880-01-03A4-5 | R1 | 1.5 | 78 | 80 | 40 | 0.14 | JBR-03 |
| ACS880-01-04A8-5 | R1 | 2.2 | 78 | 80 | 40 | 0.14 | JBR-03 |
| ACS880-01-05A2-5 | R1 | 3 | 78 | 80 | 40 | 0.14 | JBR-03 |
| ACS880-01-07A6-5 | R1 | 4 | 78 | 80 | 40 | 0.14 | JBR-03 |
| ACS880-01-11A0-5 | R1 | 5.5 | 78 | 80 | 40 | 0.14 | JBR-03 |
| ACS880-01-014A-5 | R2 | 7.5 | 39 | 44 | 210 | 1 | SACE08RE44 |
| ACS880-01-021A-5 | R2 | 11 | 39 | 44 | 210 | 1 | SACE08RE44 |
| ACS880-01-027A-5 | R3 | 15 | 19 | 22 | 420 | 2 | SACE15RE22 |
| ACS880-01-034A-5 | R3 | 18.5 | 19 | 22 | 420 | 2 | SACE15RE22 |
| ACS880-01-040A-5 | R4 | 22 | 13 | 13 | 435 | 2 | SACE15RE13 |
| ACS880-01-052A-5 | R4 | 22 | 13 | 13 | 435 | 2 | SACE15RE13 |
| ACS880-01-065A-5+D150 | R5 | 37 | 8 | 8 | 1800 | 4.5 | SAFUR90F575 |
| ACS880-01-077A-5+D150 | R5 | 45 | 8 | 8 | 1800 | 4.5 | SAFUR90F575 |
| ACS880-01-096A-5+D150 | R6 | 55 | 5.4 | 6 | 2400 | 6 | SAFUR80F500 |
| ACS880-01-124A-5+D150 | R6 | 75 | 5.4 | 6 | 2400 | 6 | SAFUR80F500 |
| ACS880-01-156A-5+D150 | R7 | 90 | 3.3 | 4 | 3600 | 9 | SAFUR125F500 |
| ACS880-01-180A-5+D150 | R7 | 110 | 3.3 | 4 | 3600 | 9 | SAFUR125F500 |
| ACS880-01-240A-5+D150 | R8 | 132 | 2.3 | 2.7 | 5400 | 13.5 | SAFUR200F500 |
| ACS880-01-260A-5+D150 | R8 | 132 | 2.3 | 2.7 | 5400 | 13.5 | SAFUR200F500 |
| ACS880-01-361A-5+D150 | R9 | 160 | 2.3 | 2.7 | 5400 | 13.5 | SAFUR200F500 |
| ACS880-01-414A-5+D150 | R9 | 160 | 2.3 | 2.7 | 5400 | 13.5 | SAFUR200F500 |
| ACS880-01-441A-5+D150 | R9 | 200 | 2.3 | 2.7 | 5400 | 13.5 | SAFUR200F500 |
| $U_N = 690 V$ | | | | | | | |
| ACS880-01-07A4-7 | R3 | 5.5 | 44 | 44 | 210 | 1 | SACE08RE44 |
| ACS880-01-09A9-7 | R3 | 7.5 | 44 | 44 | 210 | 1 | SACE08RE44 |
| ACS880-01-14A3-7 | R3 | 11 | 44 | 44 | 210 | 1 | SACE08RE44 |
| ACS880-01-019A-7 | R3 | 15 | 44 | 44 | 210 | 1 | SACE08RE44 |
| ACS880-01-023A-7 | R3 | 18.5 | 44 | 44 | 210 | 1 | SACE08RE44 |
| ACS880-01-027A-7 | R3 | 22 | 44 | 44 | 210 | 1 | SACE08RE44 |
| ACS880-01-035A-7+D150 | R5 | 33 | 18 | 22 | 420 | 2 | SACE15RE22 |
| ACS880-01-042A-7+D150 | R5 | 45 | 18 | 22 | 420 | 2 | SACE15RE22 |
| ACS880-01-049A-7+D150 | R5 | 45 | 18 | 22 | 420 | 2 | SACE15RE22 |
| ACS880-01-061A-7+D150 | R6 | 55 | 13 | 13 | 435 | 2 | SACE15RE13 |
| ACS880-01-084A-7+D150 | R6 | 65 | 13 | 13 | 435 | 2 | SACE15RE13 |
| ACS880-01-098A-7+D150 | R7 | 90 | 8 | 8 | 1800 | 4.5 | SAFUR90F575 |
| ACS880-01-119A-7+D150 | R7 | 110 | 8 | 8 | 1800 | 4.5 | SAFUR90F575 |
| ACS880-01-142A-7+D150 | R8 | 132 | 6 | 6 | 2400 | 6 | SAFUR80F500 |
| ACS880-01-174A-7+D150 | R8 | 160 | 6 | 6 | 2400 | 6 | SAFUR80F500 |
| ACS880-01-210A-7+D150 | R9 | 200 | 4 | 4 | 3600 | 9 | SAFUR125F500 |
| ACS880-01-271A-7+D150 | R9 | 200 | 4 | 4 | 3600 | 9 | SAFUR125F500 |

P_{BRcont} = The drive (drive and chopper) withstands this continuous braking power.

Braking is considered continuous if braking time exceeds 30 seconds.

R_{min} = The minimum allowed resistance of the brake resistor.

R = Resistance of the listed resistor.

E_f = Short energy pulse that the resistor assembly withstands every 400 seconds.

This energy will heat the resistor element from 40°C (104°F) to the maximum allowable temperature.

P_{rcont} = Continuous power (heat) dissipation of the resistor when placed correctly. Energy ER dissipates in 400 seconds.

ACS880-04

Voltage (V) 380-415, 380-500, 525-690

Power range (kW) 250-710

| Drive type | Frame size | Example brake resistor(s) | | | | | |
|---------------------------------|------------|---------------------------|--------------------|--------------|---------------|---------------------|--------------------------|
| | | P_{BRcont} (kW) | R_{min} (ohm) | R (ohm) | E_r (kJ) | P_{rcont} (kW) | Reference resistor types |
| $U_N = 400 V$ | | | | | | | |
| ACS880-04-505A-3+D150 | R10 | 250 | 2 | 2 | 7200 | 18 | 2xSAFUR125F500 |
| ACS880-04-585A-3+D150 | R10 | 315 | 1.3 | 1.35 | 10800 | 27 | 2xSAFUR125F500 |
| ACS880-04-650A-3+D150 | R10 | 315 | 1.3 | 1.35 | 10800 | 27 | 2xSAFUR125F500 |
| ACS880-04-725A-3+D150 | R11 | 400 | 0.7 | 0.9 | 16200 | 40 | 2xSAFUR125F500 |
| ACS880-04-820A-3+D150 | R11 | 400 | 0.7 | 0.9 | 16200 | 40 | 2xSAFUR125F500 |
| ACS880-04-880A-3+D150 | R11 | 400 | 0.7 | 0.9 | 16200 | 40 | 2xSAFUR125F500 |
| $U_N = 500 V$ | | | | | | | |
| ACS880-04-460A-5+D150 | R10 | 250 | 2 | 2 | 7200 | 18 | 2xSAFUR125F500 |
| ACS880-04-503A-5+D150 | R10 | 250 | 2 | 2 | 7200 | 18 | 2xSAFUR125F500 |
| ACS880-04-583A-5+D150 | R10 | 315 | 1.3 | 1.35 | 10800 | 27 | 2xSAFUR200F500 |
| ACS880-04-635A-5+D150 | R10 | 315 | 1.3 | 1.35 | 10800 | 27 | 2xSAFUR200F500 |
| ACS880-04-715A-5+D150 | R11 | 400 | 0.7 | 0.9 | 16200 | 40 | 3xSAFUR200F500 |
| ACS880-04-820A-5+D150 | R11 | 400 | 0.7 | 0.9 | 16200 | 40 | 3xSAFUR200F500 |
| ACS880-04-880A-5+D150 | R11 | 400 | 0.7 | 0.9 | 16200 | 40 | 3xSAFUR200F500 |
| $U_N = 690 V$ | | | | | | | |
| ACS880-04-330A-7+D150 | R10 | 285 | 2.2 | 2.7 | 3600 | 13 | SAFUR200F500 |
| ACS880-04-370A-7+D150 | R10 | 285 | 2.2 | 2.7 | 3600 | 13 | SAFUR200F500 |
| ACS880-04-430A-7+D150 | R10 | 285 | 2.2 | 2.7 | 3600 | 13 | SAFUR200F500 |
| ACS880-04-425A-7+D150 | R11 | 350 | 2 | 2 | 7200 | 18 | 2xSAFUR125F500 |
| ACS880-04-470A-7+D150 | R11 | 350 | 2 | 2 | 7200 | 18 | 2xSAFUR125F500 |
| ACS880-04-522A-7+D150 | R11 | 350 | 2 | 2 | 7200 | 18 | 2xSAFUR125F500 |
| ACS880-04-590A-7+D150 | R11 | 400 | 1.8 | 2 | 7200 | 18 | 2xSAFUR125F500 |
| ACS880-04-650A-7+D150 | R11 | 400 | 1.8 | 2 | 7200 | 18 | 2xSAFUR125F500 |
| ACS880-04-721A-7+D150 | R11 | 400 | 1.8 | 2 | 7200 | 18 | 2xSAFUR125F500 |

P_{BRcont} = The drive (drive and chopper) withstands this continuous braking power.

Braking is considered continuous if braking time exceeds 30 seconds.

R_{min} = The minimum allowed resistance of the brake resistor.

R = Resistance of the listed resistor.

E_r = Short energy pulse that the resistor assembly withstands every 400 seconds.

This energy will heat the resistor element from 40°C (104°F) to the maximum allowable temperature.

P_{rcont} = Continuous power (heat) dissipation of the resistor when placed correctly. Energy ER dissipates in 400 seconds.

ACS880-04F

Voltage (V) 380-415, 380-500, 525-690

Power range (kW) 250-710

| Drive type | Frame size | Example brake resistor(s) | | | | | |
|---------------------------------|------------|---------------------------|--------------------|--------------|---------------|---------------------|--------------------------|
| | | P_{BRcont} (kW) | R_{min} (ohm) | R (ohm) | E_r (kJ) | P_{rcont} (kW) | Reference resistor types |
| $U_N = 400 V$ | | | | | | | |
| ACS880-04F-504A-3+D150 | R10 | 250 | 2 | 2 | 7200 | 18 | 2xSAFUR125F500 |
| ACS880-04F-584A-3+D150 | R10 | 315 | 1.3 | 1.3 | 10800 | 27 | 2xSAFUR200F500 |
| ACS880-04F-649A-3+D150 | R10 | 315 | 1.3 | 1.3 | 10800 | 27 | 2xSAFUR200F500 |
| ACS880-04F-725A-3+D150 | R11 | 400 | 0.7 | 0.9 | 16200 | 40 | 3xSAFUR200F500 |
| ACS880-04F-820A-3+D150 | R11 | 400 | 0.7 | 0.9 | 16200 | 40 | 3xSAFUR200F500 |
| ACS880-04F-880A-3+D150 | R11 | 400 | 0.7 | 0.9 | 16200 | 40 | 3xSAFUR200F500 |
| $U_N = 500 V$ | | | | | | | |
| ACS880-04F-459A-5+D150 | R11 | 250 | 2 | 2 | 7200 | 18 | 2xSAFUR125F500 |
| ACS880-04F-502A-5+D150 | R11 | 250 | 2 | 2 | 7200 | 18 | 2xSAFUR125F500 |
| ACS880-04F-582A-5+D150 | R11 | 315 | 1.3 | 1.3 | 10800 | 27 | 2xSAFUR200F500 |
| ACS880-04F-634A-5+D150 | R11 | 315 | 1.3 | 1.3 | 10800 | 27 | 2xSAFUR200F500 |
| ACS880-04F-715A-5+D150 | R11 | 400 | 0.7 | 0.9 | 16200 | 40 | 3xSAFUR200F500 |
| ACS880-04F-820A-5+D150 | R11 | 400 | 0.7 | 0.9 | 16200 | 40 | 3xSAFUR200F500 |
| ACS880-04F-880A-5+D150 | R11 | 400 | 0.7 | 0.9 | 16200 | 40 | 3xSAFUR200F500 |
| $U_N = 690 V$ | | | | | | | |
| ACS880-04F-329A-7+D150 | R11 | 285 | 2.2 | 2.7 | 3600 | 13 | SAFUR200F500 |
| ACS880-04F-369A-7+D150 | R11 | 285 | 2.2 | 2.7 | 3600 | 13 | SAFUR200F500 |
| ACS880-04F-429A-7+D150 | R11 | 285 | 2.2 | 2.7 | 3600 | 13 | SAFUR200F500 |
| ACS880-04F-470A-7+D150 | R11 | 350 | 2 | 2 | 7200 | 18 | 2xSAFUR125F500 |
| ACS880-04F-522A-7+D150 | R11 | 350 | 2 | 2 | 7200 | 18 | 2xSAFUR125F500 |
| ACS880-04F-590A-7+D150 | R11 | 400 | 1.8 | 2 | 7200 | 18 | 2xSAFUR125F500 |
| ACS880-04F-650A-7+D150 | R11 | 400 | 1.8 | 2 | 7200 | 18 | 2xSAFUR125F500 |
| ACS880-04F-721A-7+D150 | R11 | 400 | 1.8 | 2 | 7200 | 18 | 2xSAFUR125F500 |

P_{BRcont} = The drive (drive and chopper) withstands this continuous braking power.
Braking is considered continuous if braking time exceeds 30 seconds.

R_{min} = The minimum allowed resistance of the brake resistor.

R = Resistance of the listed resistor.

E_r = Short energy pulse that the resistor assembly withstands every 400 seconds.

This energy will heat the resistor element from 40°C (104°F) to the maximum allowable temperature.

P_{rcont} = Continuous power (heat) dissipation of the resistor when placed correctly. Energy ER dissipates in 400 seconds.

Brake options ACS880-04XT/04FXT

ACS880-04XT uses the same brake options as ACS880-04. The ACS880-04 brake option values are for one module. As ACS880-04XT has two modules, the values need be multiplied by 2.

ACS880-04FXT uses same brake options as ACS880-04F. ACS880-04F brake option values are for one module. As ACS880-04FXT has two modules, the values need be multiplied by 2.

ACS880-37

Voltage (V) 380-415, 380-500, 525-690

Power range (kW) 250-710

| Drive type | Frame size | Example brake resistor(s) | | | |
|---------------------------------|------------|---------------------------|--------------|---------------|--------------------------|
| | | P_{BRcont} (kW) | R (ohm) | E_r (kJ) | Reference resistor types |
| $U_N = 400 V$ | | | | | |
| ACS880-37-0105A-3+D150 | R8 | 230 | 1.7 | 16800 | 2 x SAFUR210F575 |
| ACS880-37-0145A-3+D150 | R8 | 230 | 1.7 | 16800 | 2 x SAFUR210F575 |
| ACS880-37-0169A-3+D150 | R8 | 230 | 1.7 | 16800 | 2 x SAFUR210F575 |
| ACS880-37-0206A-3+D150 | R8 | 230 | 1.7 | 16800 | 2 x SAFUR210F575 |
| ACS880-37-0293A-3+D150 | R11 | 355 | 1.2 | 24000 | 2 x SAFUR180F460 |
| ACS880-37-0363A-3+D150 | R11 | 355 | 1.2 | 24000 | 2 x SAFUR180F460 |
| ACS880-37-0442A-3+D150 | R11 | 355 | 1.2 | 24000 | 2 x SAFUR180F460 |
| ACS880-37-0505A-3+D150 | R11 | 355 | 1.2 | 24000 | 2 x SAFUR180F460 |
| ACS880-37-0585A-3+D150 | R11 | 355 | 1.2 | 24000 | 2 x SAFUR180F460 |
| ACS880-37-0650A-3+D150 | R11 | 355 | 1.2 | 24000 | 2 x SAFUR180F460 |
| $U_N = 500 V$ | | | | | |
| ACS880-37-0101A-5+D150 | R8 | 268 | 2 | 14400 | 2 x SAFUR125F500 |
| ACS880-37-0124A-5+D150 | R8 | 268 | 2 | 14400 | 2 x SAFUR125F500 |
| ACS880-37-0156A-5+D150 | R8 | 268 | 2 | 14400 | 2 x SAFUR125F500 |
| ACS880-37-0180A-5+D150 | R8 | 268 | 2 | 14400 | 2 x SAFUR125F500 |
| ACS880-37-0260A-5+D150 | R11 | 403 | 1.35 | 21600 | 2 x SAFUR200F500 |
| ACS880-37-0361A-5+D150 | R11 | 403 | 1.35 | 21600 | 2 x SAFUR200F500 |
| ACS880-37-0414A-5+D150 | R11 | 403 | 1.35 | 21600 | 2 x SAFUR200F500 |
| ACS880-37-0460A-5+D150 | R11 | 403 | 1.35 | 21600 | 2 x SAFUR200F500 |
| ACS880-37-0503A-5+D150 | R11 | 403 | 1.35 | 21600 | 2 x SAFUR200F500 |
| $U_N = 690 V$ | | | | | |
| ACS880-37-0174A-7+D150 | R11 | 403 | 1.35 | | 2 x SAFUR200F500 |
| ACS880-37-0210A-7+D150 | R11 | 403 | 1.35 | | 2 x SAFUR200F500 |
| ACS880-37-0271A-7+D150 | R11 | 403 | 1.35 | | 2 x SAFUR200F500 |
| ACS880-37-0330A-7+D150 | R11 | 403 | 1.35 | | 2 x SAFUR200F500 |
| ACS880-37-0370A-7+D150 | R11 | 403 | 1.35 | | 2 x SAFUR200F500 |
| ACS880-37-0430A-7+D150 | R11 | 403 | 1.35 | | 2 x SAFUR200F500 |

P_{BRcont} = The drive (drive and chopper) withstands this continuous braking power.

Braking is considered continuous if braking time exceeds 30 seconds.

R = Resistance of the listed resistor.

E_r = Short energy pulse that the resistor assembly withstands every 400 seconds.

This energy will heat the resistor element from 40°C (104°F) to the maximum allowable temperature.

Choosing the right type of fuse

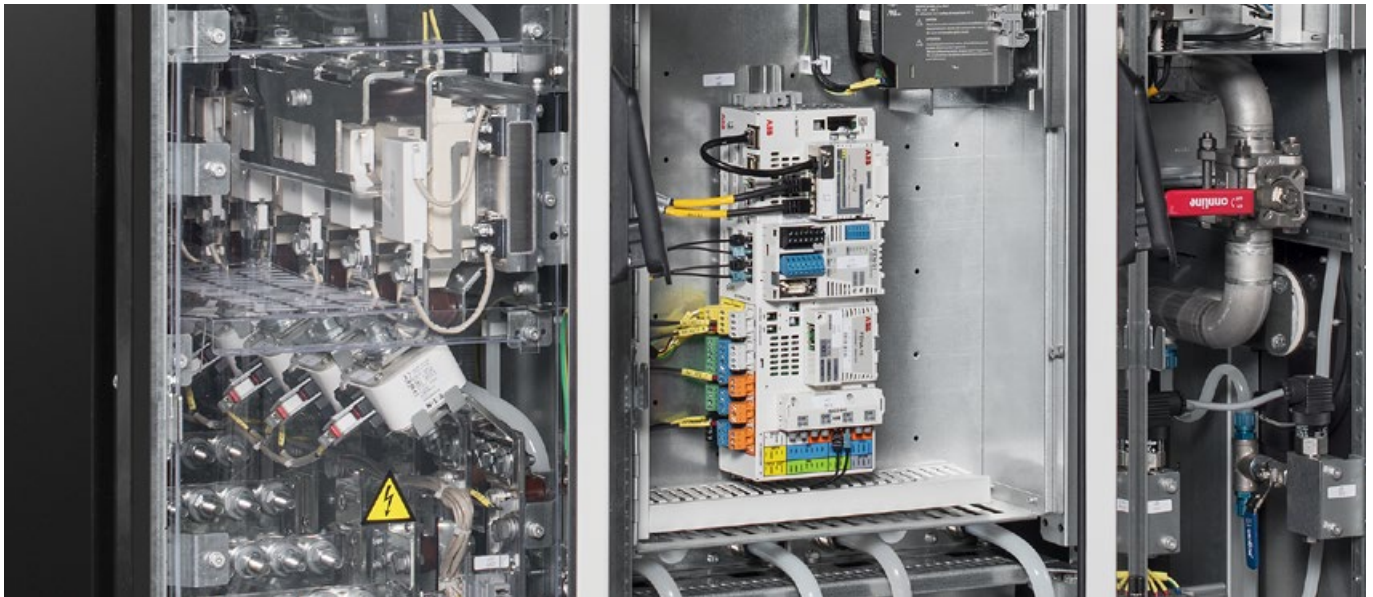

It is recommended to use the following fuse types with all-compatible drives. For mains fuse selection, see the table below. Depending on local regulations, the current range presented should be utilized.

Also, make sure that the fuse current interrupt capability meets the short circuit capability of the point of electrical coupling.

gG fuses

ACS380

| Type designation | Input current (A) | Min. short-circuit current (A) | Nominal current (A) | I^2t (A ² s) | Voltage rating (V) | ABB type | IEC 60269 size |
|---|-------------------|--------------------------------|---------------------|---------------------------|--------------------|-------------|----------------|
| 1-phase $U_N = 200...240$ V | | | | | | | |
| ACS380-04xx-02A4-1 | 5 | 80 | 10 | 380 | 500 | OFAF000H10 | 000 |
| ACS380-04xx-03A7-1 | 7.8 | 80 | 10 | 380 | 500 | OFAF000H10 | 000 |
| ACS380-04xx-04A8-1 | 10.1 | 128 | 16 | 720 | 500 | OFAF000H16 | 000 |
| ACS380-04xx-06A9-1 | 14.5 | 200 | 20 | 1500 | 500 | OFAF000H20 | 000 |
| ACS380-04xx-07A8-1 | 16.4 | 200 | 25 | 2500 | 500 | OFAF000H25 | 000 |
| ACS380-04xx-09A8-1 | 20.6 | 256 | 32 | 2500 | 500 | OFAF000H32 | 000 |
| ACS380-04xx-12A2-1 | 25.6 | 320 | 35 | 7000 | 500 | OFAF000H35 | 000 |
| 3-phase $U_N = 380...480$ V | | | | | | | |
| ACS380-04xx-01A8-4 | 2.9 | 32 | 4 | 55 | 500 | OFAF000H4 | 000 |
| ACS380-04xx-02A6-4 | 4.2 | 48 | 6 | 110 | 500 | OFAF000H6 | 000 |
| ACS380-04xx-03A3-4 | 5.3 | 48 | 6 | 110 | 500 | OFAF000H6 | 000 |
| ACS380-04xx-04A0-4 | 6.4 | 80 | 10 | 360 | 500 | OFAF000H10 | 000 |
| ACS380-04xx-05A6-4 | 9 | 80 | 10 | 360 | 500 | OFAF000H10 | 000 |
| ACS380-04xx-07A2-4 | 11.5 | 128 | 16 | 740 | 500 | OFAF000H16 | 000 |
| ACS380-04xx-09A4-4 | 15 | 128 | 16 | 740 | 500 | OFAF000H16 | 000 |
| ACS380-04xx-12A6-4 | 20.2 | 200 | 25 | 2500 | 500 | OFAF000H25 | 000 |
| ACS380-04xx-17A0-4 | 27.2 | 256 | 32 | 4500 | 500 | OFAF000H32 | 000 |
| ACS380-04xx-25A0-4 | 40 | 400 | 50 | 15500 | 500 | OFAF000H40 | 000 |
| ACS380-04xx-032A-4 | 45 | 504 | 63 | 20000 | 500 | OFAF000H63 | 000 |
| ACS380-04xx-038A-4 | 50 | 640 | 80 | 36000 | 500 | OFAF000H80 | 000 |
| ACS380-04xx-045A-4 | 56 | 800 | 100 | 65000 | 500 | OFAF000H100 | 000 |
| ACS380-04xx-050A-4 | 60 | 800 | 100 | 65000 | 500 | OFAF000H100 | 000 |

aR fuses

ACS380

| Type designation | Input current (A) | Min. short-circuit current (A) | Nominal current (A) | I^2t (A ² s) | Voltage rating (V) | Bussmann type | IEC 60269 size |
|---|-------------------|--------------------------------|---------------------|---------------------------|--------------------|---------------|----------------|
| 1-phase $U_N = 200...240$ V | | | | | | | |
| ACS380-04xx-02A4-1 | 5 | 80 | 32 | 275 | 690 | 170M2695 | 00 |
| ACS380-04xx-03A7-1 | 7.8 | 80 | 32 | 275 | 690 | 170M2695 | 00 |
| ACS380-04xx-04A8-1 | 10.1 | 128 | 40 | 490 | 690 | 170M2696 | 00 |
| ACS380-04xx-06A9-1 | 14.5 | 200 | 50 | 1000 | 690 | 170M2697 | 00 |
| ACS380-04xx-07A8-1 | 16.4 | 200 | 63 | 1800 | 690 | 170M2698 | 00 |
| ACS380-04xx-09A8-1 | 20.6 | 256 | 63 | 1800 | 690 | 170M2698 | 00 |
| ACS380-04xx-12A2-1 | 25.6 | 320 | 63 | 1800 | 690 | 170M2698 | 00 |
| 3-phase $U_N = 380...480$ V | | | | | | | |
| ACS380-04xx-01A8-4 | 2.9 | 32 | 25 | 125 | 690 | 170M2694 | 00 |
| ACS380-04xx-02A6-4 | 4.2 | 48 | 25 | 125 | 690 | 170M2694 | 00 |
| ACS380-04xx-03A3-4 | 5.3 | 48 | 25 | 125 | 690 | 170M2694 | 00 |
| ACS380-04xx-04A0-4 | 6.4 | 80 | 32 | 275 | 690 | 170M2695 | 00 |
| ACS380-04xx-05A6-4 | 9 | 80 | 32 | 275 | 690 | 170M2695 | 00 |
| ACS380-04xx-07A2-4 | 11.5 | 128 | 40 | 490 | 690 | 170M2696 | 00 |
| ACS380-04xx-09A4-4 | 15 | 128 | 40 | 490 | 690 | 170M2696 | 00 |
| ACS380-04xx-12A6-4 | 20.2 | 200 | 50 | 1000 | 690 | 170M2697 | 00 |
| ACS380-04xx-17A0-4 | 27.2 | 256 | 63 | 1800 | 690 | 170M2698 | 00 |
| ACS380-04xx-25A0-4 | 40 | 320 | 80 | 3600 | 690 | 170M2699 | 00 |
| ACS380-04xx-032A-4 | 45 | 504 | 100 | 6650 | 690 | 170M2699 | 00 |
| ACS380-04xx-038A-4 | 50 | 504 | 125 | 12000 | 690 | 170M2700 | 00 |
| ACS380-04xx-045A-4 | 56 | 640 | 160 | 22500 | 690 | 170M2700 | 00 |
| ACS380-04xx-050A-4 | 60 | 800 | 160 | 22500 | 690 | 170M2702 | 000 |

UL fuses

ACS380

| Type designation | Input current (A) | Nominal current (A) | Voltage rating (V) | Bussmann/Edison type | UL class |
|---|-------------------|---------------------|--------------------|----------------------|----------|
| 1-phase $U_N = 200...240$ V | | | | | |
| ACS380-04xx-02A4-1 | 5 | 10 | 300 | JJN/TJN10 | T |
| ACS380-04xx-03A7-1 | 7.8 | 10 | 300 | JJN/TJN10 | T |
| ACS380-04xx-04A8-1 | 10.1 | 20 | 300 | JJN/TJN20 | T |
| ACS380-04xx-06A9-1 | 14.5 | 20 | 300 | JJN/TJN20 | T |
| ACS380-04xx-07A8-1 | 16.4 | 25 | 300 | JJN/TJN25 | T |
| ACS380-04xx-09A8-1 | 20.6 | 25 | 300 | JJN/TJN25 | T |
| ACS380-04xx-12A2-1 | 25.6 | 35 | 300 | JJN/TJN35 | T |
| 3-phase $U_N = 380...480$ V | | | | | |
| ACS380-04xx-01A8-4 | 2.9 | 6 | 600 | JJS/TJS6 | T |
| ACS380-04xx-02A6-4 | 4.2 | 6 | 600 | JJS/TJS6 | T |
| ACS380-04xx-03A3-4 | 5.3 | 6 | 600 | JJS/TJS6 | T |
| ACS380-04xx-04A0-4 | 6.4 | 10 | 600 | JJS/TJS10 | T |
| ACS380-04xx-05A6-4 | 9 | 10 | 600 | JJS/TJS10 | T |
| ACS380-04xx-07A2-4 | 11.5 | 20 | 600 | JJS/TJS20 | T |
| ACS380-04xx-09A4-4 | 15 | 20 | 600 | JJS/TJS20 | T |
| ACS380-04xx-12A6-4 | 20.2 | 25 | 600 | JJS/TJS25 | T |
| ACS380-04xx-17A0-4 | 27.2 | 35 | 600 | JJS/TJS35 | T |
| ACS380-04xx-25A0-4 | 40 | 50 | 600 | JJS/TJS50 | T |
| ACS380-04xx-032A-4 | 45 | 60 | 600 | JJS/TJS60 | T |
| ACS380-04xx-038A-4 | 50 | 80 | 600 | JJS/TJS80 | T |
| ACS380-04xx-045A-4 | 56 | 100 | 600 | JJS/TJS100 | T |
| ACS380-04xx-050A-4 | 60 | 100 | 600 | JJS/TJS100 | T |

gG fuses

ACS480

| Type designation | Input current (A) | Min. short-circuit current ¹⁾ (A) | Nominal current (A) | I^2t (A ² s) | Voltage rating (V) | ABB type | IEC 60269 size |
|---|-------------------|--|---------------------|---------------------------|--------------------|-------------|----------------|
| 3-phase $U_N = 400$ V | | | | | | | |
| ACS480-04-02A7-4 | 4.2 | 48 | 6 | 110 | 500 | OFAF000H6 | 000 |
| ACS480-04-03A4-4 | 5.3 | 48 | 6 | 110 | 500 | OFAF000H6 | 000 |
| ACS480-04-04A1-4 | 6.4 | 80 | 10 | 360 | 500 | OFAF000H10 | 000 |
| ACS480-04-05A7-4 | 9 | 80 | 10 | 360 | 500 | OFAF000H10 | 000 |
| ACS480-04-07A3-4 | 11.5 | 128 | 16 | 740 | 500 | OFAF000H16 | 000 |
| ACS480-04-09A5-4 | 15 | 128 | 16 | 740 | 500 | OFAF000H16 | 000 |
| ACS480-04-12A7-4 | 20.2 | 200 | 25 | 2500 | 500 | OFAF000H25 | 000 |
| ACS480-04-018A-4 | 27.2 | 256 | 32 | 4500 | 500 | OFAF000H32 | 000 |
| ACS480-04-026A-4 | 40 | 400 | 50 | 15500 | 500 | OFAF000H50 | 000 |
| ACS480-04-033A-4 | 45 | 504 | 63 | 20000 | 500 | OFAF000H63 | 000 |
| ACS480-04-039A-4 | 50 | 640 | 80 | 36000 | 500 | OFAF000H80 | 000 |
| ACS480-04-046A-4 | 56 | 800 | 100 | 65000 | 500 | OFAF000H100 | 000 |
| ACS480-04-050A-4 | 60 | 800 | 100 | 65000 | 500 | OFAF000H100 | 000 |

¹⁾ Minimum allowed short-circuit current of the electrical power network.

gR fuses (IEC)

ACS480

| Type designation | Input current (A) | Min. short-circuit current ¹⁾ (A) | Nominal current (A) | I^2t (A ² s) | Voltage rating (V) | Bussmann type | IEC 60269 size |
|---|-------------------|--|---------------------|---------------------------|--------------------|---------------|----------------|
| 3-phase $U_N = 400$ V | | | | | | | |
| ACS480-04-03A4-4 | 5.3 | 48 | 25 | 125 | 690 | 170M2694 | 00 |
| ACS480-04-04A1-4 | 6.4 | 80 | 32 | 275 | 690 | 170M2694 | 00 |
| ACS480-04-05A7-4 | 9 | 80 | 32 | 275 | 690 | 170M2695 | 00 |
| ACS480-04-07A3-4 | 11.5 | 128 | 40 | 490 | 690 | 170M2695 | 00 |
| ACS480-04-09A5-4 | 15 | 128 | 40 | 490 | 690 | 170M2696 | 00 |
| ACS480-04-12A7-4 | 20.2 | 200 | 50 | 1000 | 690 | 170M2697 | 00 |
| ACS480-04-018A-4 | 27.2 | 256 | 63 | 1800 | 690 | 170M2698 | 00 |
| ACS480-04-026A-4 | 40 | 400 | 80 | 3600 | 690 | 170M2699 | 00 |
| ACS480-04-033A-4 | 45 | 504 | 100 | 6650 | 690 | 170M2700 | 00 |
| ACS480-04-039A-4 | 50 | 640 | 125 | 12000 | 690 | 170M2701 | 00 |
| ACS480-04-046A-4 | 56 | 800 | 160 | 22500 | 690 | 170M2702 | 00 |
| ACS480-04-050A-4 | 60 | 800 | 160 | 22500 | 690 | 170M2702 | 00 |

¹⁾ Minimum allowed short-circuit current of the electrical power network.

T fuses (UL (NEC))

ACS480

| Type designation | Input current (A) | Nominal current (A) | Voltage rating (V) | Bussmann/Edison type | UL class | Max. group fuse ¹⁾ |
|---|-------------------|---------------------|--------------------|----------------------|----------|-------------------------------|
| 3-phase $U_N = 480$ V | | | | | | |
| ACS480-04-02A7-4 | 3.4 | 6 | 600 | JJS/TJS6 | T | 25 |
| ACS480-04-03A4-4 | 4.8 | 6 | 600 | JJS/TJS6 | T | 25 |
| ACS480-04-04A1-4 | 5.6 | 10 | 600 | JJS/TJS10 | T | 25 |
| ACS480-04-05A7-4 | 7.7 | 10 | 600 | JJS/TJS10 | T | 25 |
| ACS480-04-07A3-4 | 9.6 | 20 | 600 | JJS/TJS20 | T | 25 |
| ACS480-04-09A5-4 | 12.2 | 20 | 600 | JJS/TJS20 | T | 25 |
| ACS480-04-12A7-4 | 17.6 | 25 | 600 | JJS/TJS25 | T | 30 |
| ACS480-04-018A-4 | 22.4 | 35 | 600 | JJS/TJS35 | T | 40 |
| ACS480-04-026A-4 | 33.6 | 40 | 600 | JJS/TJS40 | T | 40 |
| ACS480-04-033A-4 | 37.9 | 60 | 600 | JJS/TJS60 | T | 100 |
| ACS480-04-039A-4 | 44.7 | 80 | 600 | JJS/TJS80 | T | 100 |
| ACS480-04-050A-4 | 50.4 | 100 | 600 | JJS/TJS100 | T | 100 |

¹⁾ Branch circuit short-circuit protection for group installation by fuses: Suitable for motor group installation on a circuit that is capable of delivering no more than 65000 rms symmetrical amperes, 480 V maximum, when protected by class T fuses. The same fuse size is specified for several consecutive drive types. This is possible since the physical structure of the drive types is identical.

gG fuses

ACS580-01

| Type designation | Input current (A) | Min. short-circuit current ¹⁾ (A) | Nominal current (A) | I^2t (A ² s) | Voltage rating (V) | ABB type | IEC 60269 size |
|--|-------------------|--|---------------------|---------------------------|--------------------|-------------|----------------|
| 3-phase $U_N = 230 V$ | | | | | | | |
| ACS580-01-04A7-2 | 4.7 | 200 | 25 | 2500 | 500 | OFAF000H25 | 000 |
| ACS580-01-06A7-2 | 6.7 | 200 | 25 | 2500 | 500 | OFAF000H25 | 000 |
| ACS580-01-07A6-2 | 7.6 | 200 | 25 | 2500 | 500 | OFAF000H25 | 000 |
| ACS580-01-12A0-2 | 12 | 200 | 25 | 2500 | 500 | OFAF000H25 | 000 |
| ACS580-01-018A-2 | 16.9 | 200 | 25 | 2500 | 500 | OFAF000H25 | 000 |
| ACS580-01-025A-2 | 24.5 | 320 | 40 | 7700 | 500 | OFAF000H40 | 000 |
| ACS580-01-032A-2 | 31.2 | 320 | 40 | 7700 | 500 | OFAF000H40 | 000 |
| ACS580-01-047A-2 | 46.7 | 500 | 63 | 20100 | 500 | OFAF000H63 | 000 |
| ACS580-01-060A-2 | 60 | 500 | 63 | 20100 | 500 | OFAF000H63 | 000 |
| ACS580-01-089A-2 | 89 | 1300 | 125 | 103000 | 500 | OFAF00H125 | 00 |
| ACS580-01-115A-2 | 115 | 1300 | 125 | 103000 | 500 | OFAF00H125 | 00 |
| ACS580-01-144A-2 | 144 | 1700 | 200 | 300000 | 500 | OFAF0H200 | 0 |
| ACS580-01-171A-2 | 171 | 2300 | 250 | 600000 | 500 | OFAF0H250 | 0 |
| ACS580-01-213A-2 | 213 | 3300 | 312 | 710000 | 500 | OFAF1H315 | 1 |
| ACS580-01-276A-2 | 276 | 5500 | 400 | 1100000 | 500 | OFAF2H400 | 2 |
| 3-phase $U_N = 400$ or $480 V$ (380...415 V. 440...480 V) | | | | | | | |
| ACS580-01-02A7-4 | 2.6 | 32 | 4 | 55 | 500 | OFAF000H4 | 0 |
| ACS580-01-03A4-4 | 3.3 | 48 | 6 | 110 | 500 | OFAF000H6 | 0 |
| ACS580-01-04A1-4 | 4 | 48 | 6 | 110 | 500 | OFAF000H6 | 0 |
| ACS580-01-05A7-4 | 5.6 | 80 | 10 | 360 | 500 | OFAF000H10 | 0 |
| ACS580-01-07A3-4 | 7.2 | 80 | 10 | 360 | 500 | OFAF000H10 | 0 |
| ACS580-01-09A5-4 | 9.4 | 128 | 16 | 740 | 500 | OFAF000H16 | 0 |
| ACS580-01-12A7-4 | 12.6 | 128 | 16 | 740 | 500 | OFAF000H16 | 0 |
| ACS580-01-018A-4 | 17 | 200 | 25 | 2500 | 500 | OFAF000H25 | 0 |
| ACS580-01-026A-4 | 25 | 256 | 32 | 4000 | 500 | OFAF000H32 | 0 |
| ACS580-01-033A-4 | 32 | 320 | 40 | 7700 | 500 | OFAF000H40 | 0 |
| ACS580-01-039A-4 | 38 | 400 | 50 | 16000 | 500 | OFAF000H50 | 0 |
| ACS580-01-046A-4 | 45 | 500 | 63 | 20100 | 500 | OFAF000H63 | 0 |
| ACS580-01-062A-4 | 62 | 800 | 80 | 37500 | 500 | OFAF000H80 | 0 |
| ACS580-01-073A-4 | 73 | 1000 | 100 | 37500 | 500 | OFAF000H100 | 0 |
| ACS580-01-088A-4 | 88 | 1000 | 100 | 65000 | 500 | OFAF000H100 | 0 |
| ACS580-01-106A-4 | 106 | 1300 | 125 | 65000 | 500 | OFAF00H125 | 1 |
| ACS580-01-061A-4 | 61 | 800 | 80 | 37500 | 500 | OFAF000H80 | 0 |
| ACS580-01-072A-4 | 72 | 1000 | 100 | 65000 | 500 | OFAF000H100 | 0 |
| ACS580-01-087A-4 | 87 | 1000 | 100 | 65000 | 500 | OFAF000H100 | 0 |
| ACS580-01-105A-4 | 105 | 1300 | 125 | 103000 | 500 | OFAF00H125 | 1 |
| ACS580-01-145A-4 | 145 | 1700 | 160 | 185000 | 500 | OFAF00H160 | 1 |
| ACS580-01-169A-4 | 169 | 3300 | 250 | 600000 | 500 | OFAF0H250 | 1 |
| ACS580-01-206A-4 | 206 | 5500 | 315 | 710000 | 500 | OFAF1H315 | 1 |
| ACS580-01-246A-4 | 246 | 6400 | 355 | 920000 | 500 | OFAF1H355 | 2 |
| ACS580-01-293A-4 | 293 | 7800 | 425 | 1300000 | 500 | OFAF2H425 | 2 |
| ACS580-01-363A-4 | 363 | 9400 | 500 | 2000000 | 500 | OFAF2H500 | 2 |
| ACS580-01-430A-4 | 430 | 10200 | 630 | 2800000 | 500 | OFAF3H630 | 2 |

¹⁾ Minimum short-circuit current of the installation.

uR and aR fuses

ACS580-01

| Type designation | Input current (A) | Min. short-circuit current ¹⁾ (A) | Nominal current (A) | I^2t (A ² s) | Voltage rating (V) | Bussmann type | IEC 60269 size |
|--|-------------------|--|---------------------|---------------------------|--------------------|---------------|----------------|
| 3-phase $U_N = 230\text{ V}$ | | | | | | | |
| ACS580-01-04A7-2 | 4.7 | 120 | 40 | 460 | 690 | 170M1563 | 000 |
| ACS580-01-06A7-2 | 6.7 | 120 | 40 | 460 | 690 | 170M1563 | 000 |
| ACS580-01-07A6-2 | 7.6 | 120 | 40 | 460 | 690 | 170M1563 | 000 |
| ACS580-01-012A-2 | 12 | 120 | 40 | 460 | 690 | 170M1563 | 000 |
| ACS580-01-018A-2 | 16.9 | 120 | 40 | 460 | 690 | 170M1563 | 000 |
| ACS580-01-025A-2 | 24.5 | 170 | 63 | 1450 | 690 | 170M1565 | 000 |
| ACS580-01-032A-2 | 31.2 | 170 | 63 | 1450 | 690 | 170M1565 | 000 |
| ACS580-01-047A-2 | 46.7 | 280 | 80 | 2550 | 690 | 170M1566 | 000 |
| ACS580-01-060A-2 | 60 | 280 | 80 | 2550 | 690 | 170M1566 | 000 |
| ACS580-01-089A-2 | 89 | 700 | 200 | 15000 | 690 | 170M3815 | 1 |
| ACS580-01-115A-2 | 115 | 700 | 200 | 15000 | 690 | 170M3815 | 1 |
| ACS580-01-144A-2 | 144 | 1000 | 315 | 46500 | 690 | 170M3817 | 1 |
| ACS580-01-171A-2 | 171 | 1280 | 450 | 105000 | 690 | 170M5809 | 2 |
| ACS580-01-213A-2 | 213 | 1450 | 500 | 155000 | 690 | 170M5810 | 2 |
| ACS580-01-276A-2 | 276 | 2050 | 630 | 220000 | 690 | 170M6810 | 3 |
| 3-phase $U_N = 380...480\text{ V}$ | | | | | | | |
| ACS580-01-02A7-4 | 2.6 | 65 | 25 | 130 | 690 | 170M1561 | 0 |
| ACS580-01-03A4-4 | 3.3 | 65 | 25 | 130 | 690 | 170M1561 | 0 |
| ACS580-01-04A1-4 | 4 | 65 | 25 | 130 | 690 | 170M1561 | 0 |
| ACS580-01-05A7-4 | 5.6 | 65 | 25 | 130 | 690 | 170M1561 | 0 |
| ACS580-01-07A3-4 | 7.2 | 65 | 25 | 130 | 690 | 170M1561 | 0 |
| ACS580-01-09A5-4 | 9.4 | 65 | 25 | 130 | 690 | 170M1561 | 0 |
| ACS580-01-12A7-4 | 12.6 | 65 | 25 | 130 | 690 | 170M1561 | 0 |
| ACS580-01-018A-4 | 17 | 120 | 40 | 460 | 690 | 170M1563 | 0 |
| ACS580-01-026A-4 | 25 | 120 | 40 | 460 | 690 | 170M1563 | 0 |
| ACS580-01-033A-4 | 32 | 170 | 63 | 1450 | 690 | 170M1565 | 0 |
| ACS580-01-039A-4 | 38 | 170 | 63 | 1450 | 690 | 170M1565 | 0 |
| ACS580-01-046A-4 | 45 | 280 | 80 | 2550 | 690 | 170M1566 | 0 |
| ACS580-01-062A-4 | 62 | 380 | 100 | 4650 | 690 | 170M1567 | 0 |
| ACS580-01-073A-4 | 73 | 480 | 125 | 8500 | 690 | 170M1568 | 0 |
| ACS580-01-088A-4 | 88 | 480 | 160 | 16000 | 690 | 170M1569 | 0 |
| ACS580-01-106A-4 | 106 | 700 | 200 | 15000 | 690 | 170M3815 | 0 |
| ACS580-01-061A-4 | 61 | 380 | 100 | 4650 | 690 | 170M1567 | 0 |
| ACS580-01-072A-4 | 72 | 480 | 125 | 8500 | 690 | 170M1568 | 0 |
| ACS580-01-087A-4 | 87 | 480 | 160 | 16000 | 690 | 170M1569 | 0 |
| ACS580-01-105A-4 | 105 | 700 | 200 | 15000 | 690 | 170M3815 | 1 |
| ACS580-01-145A-4 | 145 | 700 | 250 | 28500 | 690 | 170M3816 | 1 |
| ACS580-01-169A-4 | 169 | 1280 | 315 | 46500 | 690 | 170M3817 | 1 |
| ACS580-01-206A-4 | 206 | 1520 | 350 | 68500 | 690 | 170M3818 | 1 |
| ACS580-01-246A-4 | 246 | 2050 | 450 | 105000 | 690 | 170M5809 | 2 |
| ACS580-01-293A-4 | 293 | 2200 | 500 | 145000 | 690 | 170M5810 | 2 |
| ACS580-01-363A-4 | 363 | 3100 | 630 | 275000 | 690 | 170M5812 | 2 |
| ACS580-01-430A-4 | 430 | 3600 | 700 | 405000 | 690 | 170M5813 | 2 |

¹⁾ Minimum short-circuit current of the installation

UL fuses
ACS580-01

| Type designation | Input current (A) | Nominal current (A) | Voltage rating (V) | Bussmann type | UL class |
|---|-------------------|---------------------|--------------------|---------------|----------|
| 3-phase $U_N = 380...480$ V | | | | | |
| ACS580-01-02A7-4 | 2.1 | 3 | 600 | JJS-3 | T |
| ACS580-01-03A4-4 | 3 | 6 | 600 | JJS-6 | T |
| ACS580-01-04A1-4 | 3.4 | 6 | 600 | JJS-6 | T |
| ACS580-01-05A7-4 | 4.8 | 10 | 600 | JJS-10 | T |
| ACS580-01-07A3-4 | 6 | 10 | 600 | JJS-10 | T |
| ACS580-01-09A5-4 | 7.6 | 15 | 600 | JJS-15 | T |
| ACS580-01-12A7-4 | 11 | 20 | 600 | JJS-20 | T |
| ACS580-01-018A-4 | 14 | 25 | 600 | JJS-25 | T |
| ACS580-01-026A-4 | 21 | 35 | 600 | JJS-35 | T |
| ACS580-01-033A-4 | 27 | 40 | 600 | JJS-40 | T |
| ACS580-01-039A-4 | 34 | 50 | 600 | JJS-50 | T |
| ACS580-01-046A-4 | 40 | 60 | 600 | JJS-60 | T |
| ACS580-01-062A-4 | 52 | 80 | 600 | JJS-80 | T |
| ACS580-01-073A-4 | 65 | 90 | 600 | JJS-90 | T |
| ACS580-01-088A-4 | 77 | 110 | 600 | JJS-110 | T |
| ACS580-01-145A-4 | 124 | 200 | 600 | JJS-200 | T |
| ACS580-01-169A-4 | 156 | 225 | 600 | JJS-225 | T |
| ACS580-01-206A-4 | 180 | 300 | 600 | JJS-300 | T |
| ACS580-01-246A-4 | 240 | 350 | 600 | JJS-350 | T |
| ACS580-01-293A-4 | 260 | 400 | 600 | JJS-400 | T |
| ACS580-01-363A-4 | 361 | 500 | 600 | JJS-500 | T |
| ACS580-01-430A-4 | 414 | 600 | 600 | JJS-600 | T |

—
Fuses (IEC)**ACS580-04, ultrarapid (aR) fuses**

| Type designation | Input current (A) | Type DIN 43653 (bolted style) | | | Type DIN 43620 (blade style) | | |
|--|-------------------|-------------------------------|---------------------------|----------|------------------------------|---------------------------|-----------|
| | | Nominal current (A) | I^2t (A ² s) | Fuse | Nominal current (A) | I^2t (A ² s) | Fuse |
| $U_N = 400\text{ V (380...415 V)}$ | | | | | | | |
| ACS580-04-505A-4 | 505 | 800 | 465000 | 170M6012 | 1600 | 4150000 | 170M8557D |
| ACS580-04-585A-4 | 585 | 1000 | 945000 | 170M6014 | 1600 | 4150000 | 170M8557D |
| ACS580-04-650A-4 | 650 | 1000 | 945000 | 170M6014 | 1600 | 4150000 | 170M8557D |
| ACS580-04-725A-4 | 725 | 1250 | 1950000 | 170M6016 | – | – | – |
| ACS580-04-820A-4 | 820 | 1600 | 3900000 | 170M6269 | – | – | – |
| ACS580-04-880A-4 | 880 | 1600 | 3900000 | 170M6269 | – | – | – |

Note 1: In multicable installations, install only one fuse per phase (not one fuse per conductor).

Note 2: Fuses with higher current rating than the recommended ones must not be used.

Fuses with lower current rating can be used.

Note 3: Fuses from other manufacturers can be used if they meet the ratings and the melting curve of the fuse does not exceed the melting curve of the fuse mentioned in the table.

—
UL fuses**ACS580-04**

| Type designation | Input current (A) | Nominal current (A) | Voltage rating (V) | Type | UL class |
|--|-------------------|---------------------|--------------------|-------------------|----------|
| $U_N = 440...480\text{ V (440, 460, 480 V)}$ | | | | | |
| ACS580-04-505A-4 | 505 | 600 | 600 | Bussmann: JJS-600 | T |
| ACS580-04-585A-4 | 585 | 800 | 600 | Ferraz: A4BY800 | L |
| ACS580-04-650A-4 | 650 | 800 | 600 | Ferraz: A4BY800 | L |
| ACS580-04-725A-4 | 725 | 1000 | 600 | Ferraz: A4BY1000 | L |
| ACS580-04-820A-4 | 820 | 1000 | 600 | Ferraz: A4BY1000 | L |
| ACS580-04-880A-4 | 880 | 1000 | 600 | Ferraz: A4BY1000 | L |

Note 1: In multicable installations, install only one fuse per phase (not one fuse per conductor).

Note 2: Fuses with higher current rating than the recommended ones must not be used.

Fuses with lower current rating can be used.

Note 3: Fuses from other manufacturers can be used if they meet the ratings and the melting curve of the fuse does not exceed the melting curve of the fuse mentioned in the table.

—
Fuses (IEC)

ACS580-07, ultrarapid (aR) fuses

| Type designation | Input current (A) | Nominal current (A) | I^2t (A ² s) | Voltage rating (V) | Bussmann type | Type size (Mersen) | Size |
|---------------------------------|-------------------|---------------------|---------------------------|--------------------|---------------|--------------------|------|
| $U_N = 400 V$ | | | | | | | |
| ACS580-07-145A-4 | 145 | 250 | 31000 | 690 | 170M3816D | J320375C | 1 |
| ACS580-07-169A-4 | 169 | 250 | 31000 | 690 | 170M3816D | J320375C | 1 |
| ACS580-07-206A-4 | 206 | 315 | 52000 | 690 | 170M3817D | N320379C | 1 |
| ACS580-07-246A-4 | 246 | 400 | 79000 | 690 | 170M5408 | H300065A | 2 |
| ACS580-07-293A-4 | 293 | 500 | 155000 | 690 | 170M5410 | S1046930K | 2 |
| ACS580-07-363A-4 | 363 | 630 | 210000 | 690 | 170M6410 | X300078C | 3 |
| ACS580-07-430A-4 | 430 | 700 | 300000 | 690 | 170M6411 | Y300079C | 3 |
| ACS580-07-505A-4 | 505 | 800 | 465000 | 690 | 170M6412 | W1046956F | 3 |
| ACS580-07-585A-4 | 585 | 900 | 670000 | 690 | 170M6413 | X1046957F | 3 |
| ACS580-07-650A-4 | 650 | 1000 | 945000 | 690 | 170M6414 | Y1046958F | 3 |
| ACS580-07-725A-4 | 725 | 1250 | 1950000 | 690 | 170M6416 | A1046960F | 3 |
| ACS580-07-820A-4 | 820 | 1250 | 1950000 | 690 | 170M6416 | A1046960F | 3 |
| ACS580-07-880A-4 | 880 | 1400 | 2450000 | 690 | 170M6417 | B1046961F | 3 |

Note 1: Fuses with higher current rating than the recommended ones must not be used. Fuses with lower current rating can be used.

Note 2: Fuses from other manufacturers can be used if they meet the ratings and the melting curve of the fuse does not exceed the melting curve of the fuse mentioned in the table.

—
UL fuses

ACS580-07

| Drive type | Input current (A) | | | Bussmann type | Mersen type | Bussmann type with option +F289 | Fuse (one fuse per phase) | |
|--|-------------------|------|-----|---------------|--------------------|---------------------------------|---------------------------|---------------|
| | (A) | (V) | (V) | | | | Size (option +F289) | UL class/size |
| $U_N = 480 V - NEMA$ types | | | | | | | | |
| ACS580-07-0145A-4 | 124 | 250 | 600 | DFJ-250 | B235889A (HSJ 250) | 170M3416 | 1 | J |
| ACS580-07-0169A-4 | 156 | 300 | 600 | DFJ-300 | C235890A (HSJ 300) | 170M3416 | 1 | J |
| ACS580-07-0206A-4 | 180 | 300 | 600 | DFJ-300 | C235890A (HSJ 300) | 170M4410 | 1 | J |
| ACS580-07-0246A-4 | 240 | 400 | 690 | 170M5408 | H300065A | 170M5408 | 2 | 2 |
| ACS580-07-0293A-4 | 260 | 500 | 690 | 170M5410 | S1046930K | 170M5410 | 2 | 2 |
| ACS580-07-0363A-4 | 361 | 630 | 690 | 170M6410 | X300078C | 170M6410 | 3 | 3 |
| ACS580-07-0430A-4 | 414 | 700 | 690 | 170M6411 | Y300079C | 170M6411 | 3 | 3 |
| ACS580-07-0505A-4 | 483 | 800 | 690 | 170M6412 | W1046956F | 170M6412 | 3 | 3 |
| ACS580-07-0585A-4 | 573 | 900 | 690 | 170M6413 | X1046957F | 170M6413 | 3 | 3 |
| ACS580-07-0650A-4 | 623 | 1000 | 690 | 170M6414 | Y1046958F | 170M6414 | 3 | 3 |
| ACS580-07-0725A-4 | 705 | 1250 | 690 | 170M6416 | A1046960F | 170M6416 | 3 | 3 |
| ACS580-07-0820A-4 | 807 | 1250 | 690 | 170M6416 | A1046960F | 170M6416 | 3 | 3 |
| ACS580-07-0880A-4 | 807 | 1400 | 690 | 170M6417 | B1046961F | 170M6417 | 3 | 3 |
| $U_N = 480 V - NEC$ types | | | | | | | | |
| ACS580-07-0124A-4 | 124 | 250 | 600 | DFJ-250 | B235889A (HSJ 250) | — | — | J |
| ACS580-07-0156A-4 | 156 | 300 | 600 | DFJ-300 | C235890A (HSJ 300) | — | — | J |
| ACS580-07-0180A-4 | 180 | 300 | 600 | DFJ-300 | C235890A (HSJ 300) | — | — | J |
| ACS580-07-0240A-4 | 240 | 400 | 690 | 170M5408 | H300065A | — | — | 2 |
| ACS580-07-0260A-4 | 260 | 500 | 690 | 170M5410 | S1046930K | — | — | 2 |
| ACS580-07-0361A-4 | 361 | 630 | 690 | 170M6410 | X300078C | — | — | 3 |
| ACS580-07-0414A-4 | 414 | 700 | 690 | 170M6411 | Y300079C | — | — | 3 |

Note 1: Fuses with higher current rating than the recommended ones must not be used.

Fuses with lower current rating can be used.

Note 2: Fuses from other manufacturers can be used if they meet the ratings and the melting curve of the fuse does not exceed the melting curve of the fuse mentioned in the table.

Note 3: Circuit breakers must not be used without fuses.

gG fuses

ACS880-01

| Type designation | Frame size | Input current (A) | Min. short-circuit current ¹⁾ (A) | Nominal current (A) | I^2t (A ² s) | Voltage rating (V) | ABB type | IEC size |
|---------------------------------|------------|-------------------|--|---------------------|---------------------------|--------------------|-------------|----------|
| $U_N = 230 V$ | | | | | | | | |
| ACS880-01-04A6-2 | R1 | 4.6 | 40 | 6 | 110 | 500 | OFAF000H6 | 000 |
| ACS880-01-06A6-2 | R1 | 6.6 | 80 | 10 | 360 | 500 | OFAF000H10 | 000 |
| ACS880-01-07A5-2 | R1 | 7.5 | 120 | 16 | 740 | 500 | OFAF000H16 | 000 |
| ACS880-01-10A6-2 | R1 | 10.6 | 120 | 16 | 740 | 500 | OFAF000H16 | 000 |
| ACS880-01-16A8-2 | R2 | 16.8 | 200 | 25 | 2500 | 500 | OFAF000H25 | 000 |
| ACS880-01-24A3-2 | R2 | 24.3 | 350 | 40 | 7700 | 500 | OFAF000H40 | 000 |
| ACS880-01-031A-2 | R3 | 31 | 400 | 50 | 16000 | 500 | OFAF000H50 | 000 |
| ACS880-01-046A-2 | R4 | 46 | 500 | 63 | 20100 | 500 | OFAF000H63 | 000 |
| ACS880-01-061A-2 | R4 | 61 | 800 | 80 | 37500 | 500 | OFAF000H80 | 000 |
| ACS880-01-075A-2 | R5 | 75 | 1000 | 100 | 65000 | 500 | OFAF000H100 | 000 |
| ACS880-01-087A-2 | R5 | 87 | 1300 | 125 | 100000 | 500 | OFAF000H125 | 00 |
| ACS880-01-115A-2 | R6 | 115 | 1700 | 160 | 170000 | 500 | OFAF000H160 | 00 |
| ACS880-01-145A-2 | R6 | 145 | 2300 | 200 | 300000 | 500 | OFAF000H200 | 0 |
| ACS880-01-170A-2 | R7 | 170 | 3300 | 250 | 600000 | 500 | OFAF000H250 | 0 |
| ACS880-01-206A-2 | R7 | 206 | 5500 | 315 | 710000 | 500 | OFAF1H315 | 1 |
| ACS880-01-274A-2 | R8 | 274 | 7000 | 630 | 1100000 | 500 | OFAF2H400 | 2 |
| $U_N = 400 V$ | | | | | | | | |
| ACS880-01-02A4-3 | R1 | 2.4 | 17 | 4 | 53 | 500 | OFAF000H4 | 000 |
| ACS880-01-03A3-3 | R1 | 3.3 | 40 | 6 | 110 | 500 | OFAF000H6 | 000 |
| ACS880-01-04A0-3 | R1 | 4 | 40 | 6 | 110 | 500 | OFAF000H6 | 000 |
| ACS880-01-05A6-3 | R1 | 5.6 | 80 | 10 | 355 | 500 | OFAF000H10 | 000 |
| ACS880-01-07A2-3 | R1 | 8 | 80 | 10 | 355 | 500 | OFAF000H10 | 000 |
| ACS880-01-09A4-3 | R1 | 10 | 120 | 16 | 700 | 500 | OFAF000H16 | 000 |
| ACS880-01-12A6-3 | R1 | 12.9 | 120 | 16 | 700 | 500 | OFAF000H16 | 000 |
| ACS880-01-017A-3 | R2 | 17 | 200 | 25 | 2500 | 500 | OFAF000H25 | 000 |
| ACS880-01-025A-3 | R2 | 25 | 250 | 32 | 4500 | 500 | OFAF000H32 | 000 |
| ACS880-01-032A-3 | R3 | 32 | 350 | 40 | 7700 | 500 | OFAF000H40 | 000 |
| ACS880-01-038A-3 | R3 | 38 | 400 | 50 | 15400 | 500 | OFAF000H50 | 000 |
| ACS880-01-045A-3 | R4 | 45 | 500 | 63 | 21300 | 500 | OFAF000H63 | 000 |
| ACS880-01-061A-3 | R4 | 61 | 800 | 80 | 37000 | 500 | OFAF000H80 | 000 |
| ACS880-01-072A-3 | R5 | 72 | 1000 | 100 | 63600 | 500 | OFAF000H100 | 000 |
| ACS880-01-087A-3 | R5 | 87 | 1000 | 100 | 63600 | 500 | OFAF000H100 | 000 |
| ACS880-01-105A-3 | R6 | 105 | 1300 | 125 | 103000 | 500 | OFAF000H125 | 00 |
| ACS880-01-145A-3 | R6 | 145 | 1700 | 160 | 185000 | 500 | OFAF000H160 | 00 |
| ACS880-01-169A-3 | R7 | 169 | 3300 | 250 | 600000 | 500 | OFAF000H250 | 0 |
| ACS880-01-206A-3 | R7 | 206 | 5500 | 315 | 710000 | 500 | OFAF1H315 | 1 |
| ACS880-01-246A-3 | R8 | 246 | 6400 | 355 | 920000 | 500 | OFAF1H355 | 1 |
| ACS880-01-293A-3 | R8 | 293 | 7800 | 425 | 1300000 | 500 | OFAF2H425 | 2 |
| ACS880-01-363A-3 | R9 | 363 | 9400 | 500 | 2000000 | 500 | OFAF2H500 | 2 |
| ACS880-01-430A-3 | R9 | 430 | 10200 | 630 | 2800000 | 500 | OFAF3H630 | 3 |

¹⁾ Minimum short-circuit current of the installation

gG fuses

ACS880-01

| Type designation | Frame size | Input current (A) | Min. short-circuit current ¹⁾ (A) | Nominal current (A) | I^2t (A ² s) | Voltage rating (V) | ABB type | IEC size |
|---------------------------------|------------|-------------------|--|---------------------|---------------------------|--------------------|-------------|----------|
| $U_N = 500 V$ | | | | | | | | |
| ACS880-01-02A1-5 | R1 | 2.1 | 17 | 4 | 53 | 500 | OFAF000H4 | 000 |
| ACS880-01-03A0-5 | R1 | 3 | 40 | 6 | 110 | 500 | OFAF000H6 | 000 |
| ACS880-01-03A4-5 | R1 | 3.4 | 40 | 6 | 110 | 500 | OFAF000H6 | 000 |
| ACS880-01-04A8-5 | R1 | 4.8 | 80 | 10 | 355 | 500 | OFAF000H10 | 000 |
| ACS880-01-05A2-5 | R1 | 5.2 | 80 | 10 | 355 | 500 | OFAF000H10 | 000 |
| ACS880-01-07A6-5 | R1 | 7.6 | 120 | 16 | 700 | 500 | OFAF000H16 | 000 |
| ACS880-01-11A0-5 | R1 | 11 | 120 | 16 | 700 | 500 | OFAF000H16 | 000 |
| ACS880-01-014A-5 | R2 | 14 | 200 | 25 | 2500 | 500 | OFAF000H25 | 000 |
| ACS880-01-021A-5 | R2 | 21 | 250 | 32 | 4500 | 500 | OFAF000H32 | 000 |
| ACS880-01-027A-5 | R3 | 27 | 350 | 40 | 7700 | 500 | OFAF000H40 | 000 |
| ACS880-01-034A-5 | R3 | 34 | 400 | 50 | 15400 | 500 | OFAF000H50 | 000 |
| ACS880-01-040A-5 | R4 | 40 | 500 | 63 | 21300 | 500 | OFAF000H63 | 000 |
| ACS880-01-052A-5 | R4 | 52 | 800 | 80 | 37000 | 500 | OFAF000H80 | 000 |
| ACS880-01-065A-5 | R5 | 65 | 1000 | 100 | 63600 | 500 | OFAF000H100 | 000 |
| ACS880-01-077A-5 | R5 | 77 | 1000 | 100 | 63600 | 500 | OFAF000H100 | 000 |
| ACS880-01-096A-5 | R6 | 96 | 1300 | 125 | 103000 | 500 | OFAF00H125 | 00 |
| ACS880-01-124A-5 | R6 | 124 | 1700 | 160 | 185000 | 500 | OFAF00H160 | 00 |
| ACS880-01-156A-5 | R7 | 156 | 3300 | 250 | 600000 | 500 | OFAF0H250 | 0 |
| ACS880-01-180A-5 | R7 | 180 | 5500 | 315 | 710000 | 500 | OFAF1H315 | 1 |
| ACS880-01-240A-5 | R8 | 240 | 6400 | 355 | 920000 | 500 | OFAF1H355 | 1 |
| ACS880-01-260A-5 | R8 | 260 | 7000 | 400 | 1100000 | 500 | OFAF2H400 | 2 |
| ACS880-01-361A-5 | R9 | 361 | 10200 | 630 | 2800000 | 500 | OFAF3H630 | 3 |
| ACS880-01-414A-5 | R9 | 414 | 10200 | 630 | 2800000 | 500 | OFAF3H630 | 3 |
| $U_N = 690 V$ | | | | | | | | |
| ACS880-01-07A4-7 | R3 | 7.4 | 115 | 16 | 1200 | 690 | OFAA000GG16 | 000 |
| ACS880-01-09A9-7 | R3 | 9.9 | 145 | 20 | 2400 | 690 | OFAA000GG20 | 000 |
| ACS880-01-14A3-7 | R3 | 14.3 | 190 | 25 | 4000 | 690 | OFAA000GG25 | 000 |
| ACS880-01-019A-7 | R3 | 19 | 280 | 35 | 12000 | 690 | OFAA000GG35 | 000 |
| ACS880-01-023A-7 | R3 | 23 | 450 | 50 | 24000 | 690 | OFAA000GG50 | 000 |
| ACS880-01-027A-7 | R3 | 27 | 450 | 50 | 24000 | 690 | OFAA000GG50 | 000 |
| ACS880-01-07A3-7 | R5 | 7.3 | 115 | 16 | 1200 | 690 | OFAA000GG16 | 000 |
| ACS880-01-09A8-7 | R5 | 9.8 | 145 | 20 | 2400 | 690 | OFAA000GG20 | 000 |
| ACS880-01-14A2-7 | R5 | 14.2 | 190 | 25 | 4000 | 690 | OFAA000GG25 | 000 |
| ACS880-01-018A-7 | R5 | 18 | 280 | 35 | 12000 | 690 | OFAA000GG35 | 000 |
| ACS880-01-022A-7 | R5 | 22 | 450 | 50 | 24000 | 690 | OFAA000GG50 | 000 |
| ACS880-01-026A-7 | R5 | 26 | 450 | 50 | 24000 | 690 | OFAA000GG50 | 000 |
| ACS880-01-035A-7 | R5 | 35 | 520 | 63 | 30000 | 690 | OFAA000GG63 | 000 |
| ACS880-01-042A-7 | R5 | 42 | 800 | 80 | 51000 | 690 | OFAA0GG80 | 0 |
| ACS880-01-049A-7 | R5 | 49 | 800 | 80 | 51000 | 690 | OFAA0GG80 | 0 |
| ACS880-01-061A-7 | R6 | 61 | 1050 | 100 | 95000 | 690 | OFAA0GG100 | 0 |
| ACS880-01-084A-7 | R6 | 84 | 1700 | 160 | 240000 | 690 | OFAA1GG160 | 1 |
| ACS880-01-098A-7 | R7 | 98 | 1700 | 160 | 240000 | 690 | OFAA1GG160 | 1 |
| ACS880-01-119A-7 | R7 | 119 | 2200 | 200 | 350000 | 690 | OFAA1GG200 | 1 |
| ACS880-01-142A-7 | R8 | 142 | 3200 | 250 | 700000 | 690 | OFAA1GG250 | 1 |
| ACS880-01-174A-7 | R8 | 174 | 5500 | 315 | 850000 | 690 | OFAA2GG315 | 2 |
| ACS880-01-210A-7 | R9 | 210 | 7000 | 400 | 1300000 | 690 | OFAA3GG400 | 3 |
| ACS880-01-271A-7 | R9 | 271 | 7000 | 400 | 1300000 | 690 | OFAA3GG400 | 3 |

¹⁾ Minimum short-circuit current of the installation

aR fuses

ACS880-01

| Type designation | Frame size | Input current (A) | Min. short-circuit current ¹⁾ (A) | Nominal current (A) | I^2t (A ² s) | Voltage rating (V) | Bussmann type | IEC 60269 size |
|---------------------------------|------------|-------------------|--|---------------------|---------------------------|--------------------|---------------|----------------|
| $U_N = 230 V$ | | | | | | | | |
| ACS880-01-04A6-2 | R1 | 4.6 | 30 | 16 | 48 | 690 | 170M1559 | 000 |
| ACS880-01-06A6-2 | R1 | 6.6 | 30 | 16 | 48 | 690 | 170M1559 | 000 |
| ACS880-01-07A5-2 | R1 | 7.5 | 30 | 16 | 48 | 690 | 170M1559 | 000 |
| ACS880-01-10A6-2 | R1 | 10.6 | 53 | 20 | 78 | 690 | 170M1560 | 000 |
| ACS880-01-16A8-2 | R2 | 16.8 | 65 | 25 | 130 | 690 | 170M1561 | 000 |
| ACS880-01-24A3-2 | R2 | 24.3 | 120 | 40 | 460 | 690 | 170M1563 | 000 |
| ACS880-01-031A-2 | R3 | 31 | 160 | 63 | 1450 | 690 | 170M1565 | 000 |
| ACS880-01-046A-2 | R4 | 46 | 280 | 80 | 2550 | 690 | 170M1566 | 000 |
| ACS880-01-061A-2 | R4 | 61 | 300 | 125 | 8500 | 690 | 170M1568 | 000 |
| ACS880-01-075A-2 | R5 | 75 | 380 | 200 | 15000 | 690 | 170M3815 | 1 |
| ACS880-01-087A-2 | R5 | 87 | 500 | 250 | 28500 | 690 | 170M3816 | 1 |
| ACS880-01-115A-2 | R6 | 115 | 700 | 315 | 46500 | 690 | 170M3817 | 1 |
| ACS880-01-145A-2 | R6 | 145 | 1000 | 315 | 46500 | 690 | 170M3817 | 1 |
| ACS880-01-170A-2 | R7 | 170 | 1280 | 450 | 105000 | 690 | 170M5809 | 2 |
| ACS880-01-206A-2 | R7 | 206 | 1450 | 500 | 155000 | 690 | 170M5810 | 2 |
| ACS880-01-274A-2 | R8 | 274 | 2050 | 630 | 220000 | 690 | 170M5810 | 3 |
| $U_N = 400 V$ | | | | | | | | |
| ACS880-01-02A4-3 | R1 | 2.4 | 65 | 25 | 130 | 690 | 170M1561 | 000 |
| ACS880-01-03A3-3 | R1 | 3.3 | 65 | 25 | 130 | 690 | 170M1561 | 000 |
| ACS880-01-04A0-3 | R1 | 4 | 65 | 25 | 130 | 690 | 170M1561 | 000 |
| ACS880-01-05A6-3 | R1 | 5.6 | 65 | 25 | 130 | 690 | 170M1561 | 000 |
| ACS880-01-07A2-3 | R1 | 8 | 65 | 25 | 130 | 690 | 170M1561 | 000 |
| ACS880-01-09A4-3 | R1 | 10 | 65 | 25 | 130 | 690 | 170M1561 | 000 |
| ACS880-01-12A6-3 | R1 | 12.9 | 65 | 25 | 130 | 690 | 170M1561 | 000 |
| ACS880-01-017A-3 | R2 | 17 | 120 | 40 | 460 | 690 | 170M1563 | 000 |
| ACS880-01-025A-3 | R2 | 25 | 120 | 40 | 460 | 690 | 170M1563 | 000 |
| ACS880-01-032A-3 | R3 | 32 | 170 | 63 | 1450 | 690 | 170M1565 | 000 |
| ACS880-01-038A-3 | R3 | 38 | 170 | 63 | 1450 | 690 | 170M1565 | 000 |
| ACS880-01-045A-3 | R4 | 45 | 280 | 80 | 2550 | 690 | 170M1566 | 000 |
| ACS880-01-061A-3 | R4 | 61 | 380 | 100 | 4650 | 690 | 170M1567 | 000 |
| ACS880-01-072A-3 | R5 | 72 | 480 | 125 | 8500 | 690 | 170M1568 | 000 |
| ACS880-01-087A-3 | R5 | 87 | 480 | 160 | 16000 | 690 | 170M1569 | 000 |
| ACS880-01-105A-3 | R6 | 105 | 1280 | 315 | 46500 | 690 | 170M3817 | 1 |
| ACS880-01-145A-3 | R6 | 145 | 1280 | 315 | 46500 | 690 | 170M3817 | 1 |
| ACS880-01-169A-3 | R7 | 169 | 1800 | 450 | 105000 | 690 | 170M5809 | 2 |
| ACS880-01-206A-3 | R7 | 206 | 2210 | 500 | 145000 | 690 | 170M5810 | 2 |
| ACS880-01-246A-3 | R8 | 246 | 3010 | 630 | 275000 | 690 | 170M5812 | 2 |
| ACS880-01-293A-3 | R8 | 293 | 4000 | 800 | 490000 | 690 | 170M6812D | 3 |
| ACS880-01-363A-3 | R9 | 363 | 5550 | 1000 | 985000 | 690 | 170M6814D | 3 |
| ACS880-01-430A-3 | R9 | 430 | 7800 | 1250 | 2150000 | 690 | 170M8554D | 3 |

¹⁾ Minimum short-circuit current of the installation

aR fuses

ACS880-01

| Type designation | Frame size | Input current (A) | Min. short-circuit current ¹⁾ (A) | Nominal current (A) | I^2t (A ² s) | Voltage rating (V) | Bussmann type | IEC 60269 size |
|---------------------------------|------------|-------------------|--|---------------------|---------------------------|--------------------|---------------|----------------|
| $U_N = 500 V$ | | | | | | | | |
| ACS880-01-02A1-5 | R1 | 2.1 | 65 | 25 | 130 | 690 | 170M1561 | 0 |
| ACS880-01-03A0-5 | R1 | 3 | 65 | 25 | 130 | 690 | 170M1561 | 0 |
| ACS880-01-03A4-5 | R1 | 3.4 | 65 | 25 | 130 | 690 | 170M1561 | 0 |
| ACS880-01-04A8-5 | R1 | 4.8 | 65 | 25 | 130 | 690 | 170M1561 | 0 |
| ACS880-01-05A2-5 | R1 | 5.2 | 65 | 25 | 130 | 690 | 170M1561 | 0 |
| ACS880-01-07A6-5 | R1 | 7.6 | 65 | 25 | 130 | 690 | 170M1561 | 0 |
| ACS880-01-11A0-5 | R1 | 11 | 65 | 25 | 130 | 690 | 170M1561 | 0 |
| ACS880-01-014A-5 | R2 | 14 | 120 | 40 | 460 | 690 | 170M1563 | 0 |
| ACS880-01-021A-5 | R2 | 21 | 120 | 40 | 460 | 690 | 170M1563 | 0 |
| ACS880-01-027A-5 | R3 | 27 | 170 | 63 | 1450 | 690 | 170M1565 | 0 |
| ACS880-01-034A-5 | R3 | 34 | 170 | 63 | 1450 | 690 | 170M1565 | 0 |
| ACS880-01-040A-5 | R4 | 40 | 280 | 80 | 2550 | 690 | 170M1566 | 0 |
| ACS880-01-052A-5 | R4 | 52 | 300 | 100 | 4650 | 690 | 170M1567 | 0 |
| ACS880-01-065A-5 | R5 | 65 | 480 | 125 | 8500 | 690 | 170M1568 | 0 |
| ACS880-01-077A-5 | R5 | 77 | 480 | 160 | 16000 | 690 | 170M1569 | 0 |
| ACS880-01-096A-5 | R6 | 96 | 700 | 200 | 15000 | 690 | 170M3815 | 1 |
| ACS880-01-124A-5 | R6 | 124 | 700 | 250 | 28500 | 690 | 170M3816 | 1 |
| ACS880-01-156A-5 | R7 | 156 | 1280 | 315 | 46500 | 690 | 170M3817 | 1 |
| ACS880-01-180A-5 | R7 | 180 | 1280 | 315 | 46500 | 690 | 170M3817 | 1 |
| ACS880-01-240A-5 | R8 | 240 | 1520 | 400 | 74000 | 690 | 170M5808 | 2 |
| ACS880-01-260A-5 | R8 | 260 | 1710 | 450 | 105000 | 690 | 170M5809 | 2 |
| ACS880-01-361A-5 | R9 | 361 | 2620 | 630 | 275000 | 690 | 170M5812 | 2 |
| ACS880-01-414A-5 | R9 | 414 | 3010 | 700 | 405000 | 690 | 170M5813 | 2 |
| $U_N = 690 V$ | | | | | | | | |
| ACS880-01-07A4-7 | R3 | 7.4 | 40 | 16 | 48 | 690 | 170M1559 | 000 |
| ACS880-01-09A9-7 | R3 | 9.9 | 53 | 20 | 78 | 690 | 170M1560 | 000 |
| ACS880-01-14A3-7 | R3 | 14.3 | 94 | 32 | 270 | 690 | 170M1562 | 000 |
| ACS880-01-019A-7 | R3 | 19 | 120 | 40 | 460 | 690 | 170M1563 | 000 |
| ACS880-01-023A-7 | R3 | 23 | 160 | 50 | 770 | 690 | 170M1564 | 000 |
| ACS880-01-027A-7 | R3 | 27 | 160 | 50 | 770 | 690 | 170M1564 | 000 |
| ACS880-01-07A3-7 | R5 | 7.3 | 40 | 16 | 48 | 690 | 170M1559 | 000 |
| ACS880-01-09A8-7 | R5 | 9.8 | 53 | 20 | 78 | 690 | 170M1560 | 000 |
| ACS880-01-14A2-7 | R5 | 14.2 | 94 | 32 | 270 | 690 | 170M1562 | 000 |
| ACS880-01-018A-7 | R5 | 18 | 120 | 40 | 460 | 690 | 170M1563 | 000 |
| ACS880-01-022A-7 | R5 | 22 | 160 | 50 | 770 | 690 | 170M1564 | 000 |
| ACS880-01-026A-7 | R5 | 26 | 160 | 50 | 770 | 690 | 170M1564 | 000 |
| ACS880-01-035A-7 | R5 | 35 | 170 | 63 | 1450 | 690 | 170M1565 | 000 |
| ACS880-01-042A-7 | R5 | 42 | 280 | 80 | 2550 | 690 | 170M1566 | 000 |
| ACS880-01-049A-7 | R5 | 49 | 280 | 80 | 2550 | 690 | 170M1566 | 000 |
| ACS880-01-061A-7 | R6 | 61 | 480 | 125 | 8500 | 690 | 170M1568 | 000 |
| ACS880-01-084A-7 | R6 | 84 | 700 | 160 | 16000 | 690 | 170M1569 | 000 |
| ACS880-01-098A-7 | R7 | 98 | 1610 | 400 | 74000 | 690 | 170M3816 | 2 |
| ACS880-01-119A-7 | R7 | 119 | 1610 | 400 | 74000 | 690 | 170M3816 | 2 |
| ACS880-01-142A-7 | R8 | 142 | 2210 | 500 | 145000 | 690 | 170M5810 | 2 |
| ACS880-01-174A-7 | R8 | 174 | 2210 | 500 | 145000 | 690 | 170M5810 | 2 |
| ACS880-01-210A-7 | R9 | 210 | 3200 | 700 | 320000 | 690 | 170M6811D | 3 |
| ACS880-01-271A-7 | R9 | 271 | 3200 | 700 | 320000 | 690 | 170M6811D | 3 |

¹⁾ Minimum short-circuit current of the installation

—
UL fuses

ACS880-01

| Type designation | Frame size | Input current (A) | Nominal current (A) | Voltage rating (V) | Bussmann type | UL class |
|--|------------|-------------------|---------------------|--------------------|---------------|----------|
| $U_N = 230\text{ V}$ | | | | | | |
| ACS880-01-04A6-2 | R1 | 4.4 | 15 | 600 | JJS-15 | T |
| ACS880-01-06A6-2 | R1 | 6.3 | 15 | 600 | JJS-15 | T |
| ACS880-01-07A5-2 | R1 | 7.1 | 15 | 600 | JJS-15 | T |
| ACS880-01-10A6-2 | R1 | 10.1 | 20 | 600 | JJS-20 | T |
| ACS880-01-16A8-2 | R2 | 16.0 | 25 | 600 | JJS-25 | T |
| ACS880-01-24A3-2 | R2 | 23.1 | 40 | 600 | JJS-40 | T |
| ACS880-01-031A-2 | R3 | 29.3 | 50 | 600 | JJS-50 | T |
| ACS880-01-046A-2 | R4 | 44 | 80 | 600 | JJS-80 | T |
| ACS880-01-061A-2 | R4 | 58 | 100 | 600 | JJS-100 | T |
| ACS880-01-075A-2 | R5 | 71 | 125 | 600 | JJS-125 | T |
| ACS880-01-087A-2 | R5 | 83 | 125 | 600 | JJS-125 | T |
| ACS880-01-115A-2 | R6 | 109 | 150 | 600 | JJS-150 | T |
| ACS880-01-145A-2 | R6 | 138 | 200 | 600 | JJS-200 | T |
| ACS880-01-170A-2 | R7 | 162 | 250 | 600 | JJS-250 | T |
| ACS880-01-206A-2 | R7 | 196 | 300 | 600 | JJS-300 | T |
| ACS880-01-274A-2 | R8 | 260 | 400 | 600 | JJS-400 | T |
| $U_N = 460\text{ V}$ | | | | | | |
| ACS880-01-02A1-5 | R1 | 2.1 | 3 | 600 | JJS-3 | T |
| ACS880-01-03A0-5 | R1 | 3 | 6 | 600 | JJS-6 | T |
| ACS880-01-03A4-5 | R1 | 3.4 | 6 | 600 | JJS-6 | T |
| ACS880-01-04A8-5 | R1 | 4.8 | 10 | 600 | JJS-10 | T |
| ACS880-01-05A2-5 | R1 | 5.2 | 10 | 600 | JJS-10 | T |
| ACS880-01-07A6-5 | R1 | 7.6 | 15 | 600 | JJS-15 | T |
| ACS880-01-11A0-5 | R1 | 11 | 20 | 600 | JJS-20 | T |
| ACS880-01-014A-5 | R2 | 14 | 25 | 600 | JJS-25 | T |
| ACS880-01-021A-5 | R2 | 21 | 35 | 600 | JJS-35 | T |
| ACS880-01-027A-5 | R3 | 27 | 40 | 600 | JJS-40 | T |
| ACS880-01-034A-5 | R3 | 34 | 50 | 600 | JJS-50 | T |
| ACS880-01-040A-5 | R4 | 40 | 60 | 600 | JJS-60 | T |
| ACS880-01-052A-5 | R4 | 52 | 80 | 600 | JJS-80 | T |
| ACS880-01-065A-5 | R5 | 65 | 90 | 600 | JJS-90 | T |
| ACS880-01-077A-5 | R5 | 77 | 110 | 600 | JJS-110 | T |
| ACS880-01-096A-5 | R6 | 96 | 150 | 600 | JJS-150 | T |
| ACS880-01-124A-5 | R6 | 124 | 200 | 600 | JJS-200 | T |
| ACS880-01-156A-5 | R7 | 156 | 225 | 600 | JJS-225 | T |
| ACS880-01-180A-5 | R7 | 180 | 300 | 600 | JJS-300 | T |
| ACS880-01-240A-5 | R8 | 240 | 350 | 600 | JJS-350 | T |
| ACS880-01-260A-5 | R8 | 260 | 400 | 600 | JJS-400 | T |
| ACS880-01-302A-5 | R9 | 302 | 400 | 600 | JJS-400 | T |
| ACS880-01-361A-5 | R9 | 361 | 500 | 600 | JJS-500 | T |
| ACS880-01-414A-5 | R9 | 414 | 600 | 600 | JJS-600 | T |

¹⁾ Minimum short-circuit current of the installation

UL fuses
ACS880-01

| Type designation | Frame size | Input current (A) | Nominal current (A) | Voltage rating (V) | Bussmann type | UL class |
|--|------------|-------------------|---------------------|--------------------|---------------|----------|
| $U_N = 575\text{ V}$ | | | | | | |
| ACS880-01-07A4-7 | R3 | 7.0 | 15 | 600 | JJS-15 | T |
| ACS880-01-09A9-7 | R3 | 9.4 | 20 | 600 | JJS-20 | T |
| ACS880-01-14A3-7 | R3 | 13.6 | 30 | 600 | JJS-30 | T |
| ACS880-01-019A-7 | R3 | 18 | 40 | 600 | JJS-40 | T |
| ACS880-01-023A-7 | R3 | 22 | 50 | 600 | JJS-50 | T |
| ACS880-01-027A-7 | R3 | 27 | 50 | 600 | JJS-50 | T |
| ACS880-01-07A3-7 | R5 | 9.0 | 15 | 600 | JJS-15 | T |
| ACS880-01-09A8-7 | R5 | 11 | 20 | 600 | JJS-20 | T |
| ACS880-01-14A2-7 | R5 | 17 | 30 | 600 | JJS-30 | T |
| ACS880-01-018A-7 | R5 | 22 | 40 | 600 | JJS-40 | T |
| ACS880-01-022A-7 | R5 | 27 | 50 | 600 | JJS-50 | T |
| ACS880-01-026A-7 | R5 | 32 | 50 | 600 | JJS-50 | T |
| ACS880-01-035A-7 | R5 | 41 | 60 | 600 | JJS-60 | T |
| ACS880-01-042A-7 | R5 | 52 | 80 | 600 | JJS-80 | T |
| ACS880-01-049A-7 | R5 | 52 | 80 | 600 | JJS-80 | T |
| ACS880-01-061A-7 | R6 | 62 | 110 | 600 | JJS-110 | T |
| ACS880-01-084A-7 | R6 | 77 | 150 | 600 | JJS-150 | T |
| ACS880-01-098A-7 | R7 | 99 | 150 | 600 | JJS-150 | T |
| ACS880-01-119A-7 | R7 | 125 | 200 | 600 | JJS-200 | T |
| ACS880-01-142A-7 | R8 | 144 | 250 | 600 | JJS-250 | T |
| ACS880-01-174A-7 | R8 | 180 | 300 | 600 | JJS-300 | T |
| ACS880-01-210A-7 | R9 | 242 | 400 | 600 | JJS-400 | T |
| ACS880-01-271A-7 | R9 | 271 | 400 | 600 | JJS-400 | T |

¹⁾ Minimum short-circuit current of the installation

—
aR fuses

ACS880-04, ultrarapid (aR) fuses

| Type designation | Frame size | Input current (A) | Nominal current (A) | I^2t (A ² s) | Voltage rating (V) | Bussmann type DIN 43620 | Size |
|--|------------|-------------------|---------------------|---------------------------|--------------------|-------------------------|------|
| $U_N = 400\text{ V}$ | | | | | | | |
| ACS880-04-505A-3 | R10 | 505 | 800 | 490000 | 690 | 170M6812D | DIN3 |
| ACS880-04-585A-3 | R10 | 585 | 1000 | 985000 | 690 | 170M6814D | DIN3 |
| ACS880-04-650A-3 | R10 | 650 | 1000 | 985000 | 690 | 170M6814D | DIN3 |
| ACS880-04-725A-3 | R11 | 725 | 1250 | 2150000 | 690 | 170M8554D | DIN3 |
| ACS880-04-820A-3 | R11 | 820 | 1600 | 4150000 | 690 | 170M8557D | DIN3 |
| ACS880-04-880A-3 | R11 | 880 | 1600 | 4150000 | 690 | 170M8557D | DIN3 |
| $U_N = 500\text{ V}$ | | | | | | | |
| ACS880-04-460A-5 | R10 | 460 | 630 | 490000 | 690 | 170M6810D | DIN3 |
| ACS880-04-503A-5 | R10 | 503 | 800 | 490000 | 690 | 170M6812D | DIN3 |
| ACS880-04-583A-5 | R10 | 583 | 1000 | 985000 | 690 | 170M6814D | DIN3 |
| ACS880-04-635A-5 | R10 | 635 | 1000 | 985000 | 690 | 170M6814D | DIN3 |
| ACS880-04-715A-5 | R11 | 715 | 1250 | 2150000 | 690 | 170M8554D | DIN3 |
| ACS880-04-820A-5 | R11 | 820 | 1600 | 4150000 | 690 | 170M8557D | DIN3 |
| ACS880-04-880A-5 | R11 | 880 | 1600 | 4150000 | 690 | 170M8557D | 3 |
| $U_N = 690\text{ V}$ | | | | | | | |
| ACS880-04-330A-7 | R10 | 330 | 700 | 320000 | 690 | 170M6811D | 3 |
| ACS880-04-370A-7 | R10 | 370 | 900 | 720000 | 690 | 170M6813D | 3 |
| ACS880-04-430A-7 | R10 | 430 | 1000 | 985000 | 690 | 170M6814D | 3 |
| ACS880-04-425A-7 | R11 | 425 | 1000 | 985000 | 690 | 170M6814D | 3 |
| ACS880-04-470A-7 | R11 | 470 | 1100 | 1400000 | 690 | 170M6892D | 3 |
| ACS880-04-522A-7 | R11 | 522 | 1250 | 2150000 | 690 | 170M8554D | 3 |
| ACS880-04-590A-7 | R11 | 590 | 1400 | 2700000 | 690 | 170M8555D | 3 |
| ACS880-04-650A-7 | R11 | 650 | 1500 | 3350000 | 690 | 170M8556D | 3 |
| ACS880-04-721A-7 | R11 | 721 | 1500 | 3350000 | 690 | 170M8556D | DIN3 |

—
UL fuses

ACS880-04

| Type designation | Frame size | Input current (A) | Nominal current (A) | Voltage rating (V) | Type | UL class |
|--|------------|-------------------|---------------------|--------------------|-------------------|----------|
| $U_N = 400\text{ V}$ | | | | | | |
| ACS880-04-505A-3 | R10 | 505 | 600 | 600 | Bussmann: JJS-600 | T |
| ACS880-04-585A-3 | R10 | 585 | 800 | 600 | Ferraz: A4BY800 | L |
| ACS880-04-650A-3 | R10 | 650 | 800 | 600 | Ferraz: A4BY800 | L |
| ACS880-04-725A-3 | R11 | 725 | 800 | 600 | Ferraz: A4BY800 | L |
| ACS880-04-820A-3 | R11 | 820 | 900 | 600 | Ferraz: A4BY900 | L |
| ACS880-04-880A-3 | R11 | 880 | 1000 | 600 | Ferraz: A4BY1000 | L |
| $U_N = 460\text{ V}$ | | | | | | |
| ACS880-04-460A-5 | R10 | 460 | 600 | 500 | Bussmann: JJS-500 | T |
| ACS880-04-503A-5 | R10 | 503 | 600 | 600 | Bussmann: JJS-600 | T |
| ACS880-04-583A-5 | R10 | 583 | 800 | 600 | Ferraz: A4BY800 | L |
| ACS880-04-635A-5 | R10 | 635 | 800 | 600 | Ferraz: A4BY800 | L |
| ACS880-04-715A-5 | R11 | 715 | 800 | 600 | Ferraz: A4BY800 | L |
| ACS880-04-820A-5 | R11 | 820 | 900 | 600 | Ferraz: A4BY900 | L |
| ACS880-04-880A-5 | R11 | 880 | 1000 | 600 | Ferraz: A4BY1000 | L |
| $U_N = 600\text{ V}$ | | | | | | |
| ACS880-04-330A-7 | R10 | 330 | 500 | 600 | Bussmann: JJS-500 | T |
| ACS880-04-370A-7 | R10 | 370 | 500 | 600 | Bussmann: JJS-500 | T |
| ACS880-04-430A-7 | R10 | 430 | 500 | 600 | Bussmann: JJS-500 | T |
| ACS880-04-425A-7 | R11 | | | | | |
| ACS880-04-470A-7 | R11 | 470 | 600 | 600 | Bussmann: JJS-600 | T |
| ACS880-04-522A-7 | R11 | 522 | 600 | 600 | Bussmann: JJS-600 | T |
| ACS880-04-590A-7 | R11 | 590 | 800 | 600 | Ferraz: A4BY800 | L |
| ACS880-04-650A-7 | R11 | 650 | 800 | 600 | Ferraz: A4BY800 | L |
| ACS880-04-721A-7 | R11 | 721 | 800 | 600 | Ferraz: A4BY800 | L |

Note 1: In multicable installations, install only one fuse per phase (not one fuse per conductor).

Note 2: Fuses with higher current rating than the recommended ones must not be used. Fuses with lower current rating can be used.

Note 3: Fuses from other manufacturers can be used if they agree with the ratings and the melting curve of the fuse does not exceed the melting curve of the fuse mentioned in the table.

—
aR fuses

ACS880-04XT, ultrarapid (aR) fuses

| Type designation | Frame size | Input current (A) | Nominal current (A) | I^2t (A ² s) | Voltage rating (V) | Bussmann type Type DIN 43653 With trip indicator (Without trip indicator) | Size |
|--|------------|----------------------|------------------------|------------------------------|-----------------------|--|------|
| $U_N = 400\text{ V}$ | | | | | | | |
| ACS880-04XT-1010A-3 | 2×R10 | 1010 | 1000 | 945 000 | 690 | 170M6064(170M6014) | 3 |
| ACS880-04XT-1190A-3 | 2×R10 | 1190 | 1000 | 945 000 | 690 | 170M6064(170M6014) | 3 |
| ACS880-04XT-1330A-3 | 2×R11 | 1330 | 1250 | 1 950 000 | 690 | 170M6066(170M6016) | 3 |
| ACS880-04XT-1610A-3 | 2×R11 | 1610 | 1600 | 3 900 000 | 690 | 170M6069(170M6019) | 3 |
| $U_N = 500\text{ V}$ | | | | | | | |
| ACS880-04XT-1010A-5 | 2×R10 | 1010 | 1000 | 945 000 | 690 | 170M6064(170M6014) | 3 |
| ACS880-04XT-1160A-5 | 2×R10 | 1160 | 1000 | 945 000 | 690 | 170M6064(170M6014) | 3 |
| ACS880-04XT-1310A-5 | 2×R11 | 1310 | 1250 | 1 950 000 | 690 | 170M6066(170M6016) | 3 |
| ACS880-04XT-1610A-5 | 2×R11 | 1610 | 1600 | 3 900 000 | 690 | 170M6069(170M6019) | 3 |
| $U_N = 690\text{ V}$ | | | | | | | |
| ACS880-04XT-0810A-7 | 2×R10 | 810 | 1000 | 945 000 | 690 | 170M6064(170M6014) | 3 |
| ACS880-04XT-0960A-7 | 2×R11 | 960 | 1250 | 1 950 000 | 690 | 170M6066(170M6016) | 3 |
| ACS880-04XT-1080A-7 | 2×R11 | 1080 | 1400 | 2 450 000 | 690 | 170M6067(170M6017) | 3 |
| ACS880-04XT-1320A-7 | 2×R11 | 1320 | 1500 | 3 100 000 | 690 | 170M6068(170M6018) | 3 |

—
UL fuses

ACS880-04XT

| Type designation | Frame size | Input current (A) | Nominal current (A) | Voltage rating (V) | Type | UL class |
|--|------------|----------------------|------------------------|-----------------------|-------------------|----------|
| $U_N = 400\text{ V}$ | | | | | | |
| ACS880-04XT-1010A-3 | 2×R10 | 1010 | 800 | 600 | Ferraz: A4BY800 | L |
| ACS880-04XT-1190A-3 | 2×R10 | 1190 | 800 | 600 | Ferraz: A4BY800 | L |
| ACS880-04XT-1330A-3 | 2×R11 | 1330 | 800 | 600 | Ferraz: A4BY800 | L |
| ACS880-04XT-1610A-3 | 2×R11 | 1610 | 1000 | 600 | Ferraz: A4BY1000 | L |
| $U_N = 460\text{ V}$ | | | | | | |
| ACS880-04XT-1010A-5 | 2×R10 | 1010 | 800 | 600 | Ferraz: A4BY800 | L |
| ACS880-04XT-1160A-5 | 2×R10 | 1160 | 800 | 600 | Ferraz: A4BY800 | L |
| ACS880-04XT-1310A-5 | 2×R11 | 1310 | 800 | 600 | Ferraz: A4BY800 | L |
| ACS880-04XT-1610A-5 | 2×R11 | 1610 | 1000 | 600 | Ferraz: A4BY1000 | L |
| $U_N = 600\text{ V}$ | | | | | | |
| ACS880-04XT-0810A-7 | 2×R10 | 810 | 500 | 600 | Bussmann: JJS-500 | T |
| ACS880-04XT-0960A-7 | 2×R11 | 960 | 600 | 600 | Bussmann: JJS-600 | T |
| ACS880-04XT-1080A-7 | 2×R11 | 1080 | 800 | 600 | Ferraz: A4BY800 | L |
| ACS880-04XT-1320A-7 | 2×R11 | 1320 | 800 | 600 | Ferraz: A4BY800 | L |

Note 1: In multicable installations, install only one fuse per phase (not one fuse per conductor).

Note 2: Fuses with higher current rating than the recommended ones must not be used. Fuses with lower current rating can be used.

Note 3: Fuses from other manufacturers can be used if they agree with the ratings and the melting curve of the fuse does not exceed the melting curve of the fuse mentioned in the table.

aR fuses

ACS880-04F

| Type designation | Frame size | Input current (A) | Nominal current (A) | I^2t (A ² s) | Voltage rating (V) | Bussmann type DIN 43620 | Size |
|--|------------|-------------------|---------------------|---------------------------|--------------------|-------------------------|------|
| $U_N = 400\text{ V}$ | | | | | | | |
| ACS880-04F-504A-3 | R11 | 504 | 800 | 465000 | 690 | 170M6012 | 3 |
| ACS880-04F-584A-3 | R11 | 584 | 1000 | 945000 | 690 | 170M6014 | 3 |
| ACS880-04F-649A-3 | R11 | 649 | 1000 | 945000 | 690 | 170M6014 | 3 |
| ACS880-04F-725A-3 | R11 | 725 | 1250 | 1950000 | 690 | 170M6016 | 3 |
| ACS880-04F-820A-3 | R11 | 820 | 1600 | 3900000 | 690 | 170M6269 | 3 |
| ACS880-04F-880A-3 | R11 | 880 | 1600 | 3900000 | 690 | 170M6269 | 3 |
| $U_N = 500\text{ V}$ | | | | | | | |
| ACS880-04F-459A-5 | R11 | 459 | 630 | 210000 | 690 | 170M6010 | 3 |
| ACS880-04F-502A-5 | R11 | 502 | 800 | 465000 | 690 | 170M6012 | 3 |
| ACS880-04F-582A-5 | R11 | 582 | 1000 | 945000 | 690 | 170M6014 | 3 |
| ACS880-04F-634A-5 | R11 | 634 | 1000 | 945000 | 690 | 170M6014 | 3 |
| ACS880-04F-715A-5 | R11 | 715 | 1250 | 1950000 | 690 | 170M6016 | 3 |
| ACS880-04F-820A-5 | R11 | 820 | 1600 | 3900000 | 690 | 170M6269 | 3 |
| ACS880-04F-880A-5 | R11 | 880 | 1600 | 3900000 | 690 | 170M6269 | 3 |
| $U_N = 690\text{ V}$ | | | | | | | |
| ACS880-04F-329A-7 | R11 | 329 | 700 | 300000 | 690 | 170M6011 | 3 |
| ACS880-04F-369A-7 | R11 | 369 | 900 | 670000 | 690 | 170M6013 | 3 |
| ACS880-04F-429A-7 | R11 | 429 | 1000 | 945000 | 690 | 170M6014 | 3 |
| ACS880-04F-470A-7 | R11 | 470 | 1000 | 945000 | 690 | 170M6014 | 3 |
| ACS880-04F-522A-7 | R11 | 522 | 1100 | 1300000 | 690 | 170M6015 | 3 |
| ACS880-04F-590A-7 | R11 | 590 | 1250 | 1950000 | 690 | 170M6016 | 3 |
| ACS880-04F-650A-7 | R11 | 650 | 1400 | 2450000 | 690 | 170M6017 | 3 |
| ACS880-04F-721A-7 | R11 | 721 | 1500 | 3100000 | 690 | 170M6018 | 3 |

UL fuses

ACS880-04F

| Type designation | Frame size | Input current (A) | Nominal current (A) | Voltage rating (V) | Type | UL class |
|--|------------|-------------------|---------------------|--------------------|-------------------|----------|
| $U_N = 400\text{ V}$ | | | | | | |
| ACS880-04F-504A-3 | R11 | 504 | 600 | 600 | Bussmann: JJS-600 | T |
| ACS880-04F-584A-3 | R11 | 584 | 800 | 600 | Ferraz: A4BY800 | L |
| ACS880-04F-649A-3 | R11 | 649 | 800 | 600 | Ferraz: A4BY800 | L |
| ACS880-04F-725A-3 | R11 | 725 | 800 | 600 | Ferraz: A4BY800 | L |
| ACS880-04F-820A-3 | R11 | 820 | 1000 | 600 | Ferraz: A4BY1000 | L |
| ACS880-04F-880A-3 | R11 | 880 | 1000 | 600 | Ferraz: A4BY1000 | L |
| $U_N = 460\text{ V}$ | | | | | | |
| ACS880-04F-459A-5 | R11 | 459 | 600 | 600 | Bussmann: JJS-500 | T |
| ACS880-04F-502A-5 | R11 | 502 | 600 | 600 | Bussmann: JJS-600 | T |
| ACS880-04F-582A-5 | R11 | 582 | 800 | 600 | Ferraz: A4BY800 | L |
| ACS880-04F-634A-5 | R11 | 634 | 800 | 600 | Ferraz: A4BY800 | L |
| ACS880-04F-715A-5 | R11 | 715 | 1000 | 600 | Ferraz: A4BY1000 | L |
| ACS880-04F-820A-5 | R11 | 820 | 1000 | 600 | Ferraz: A4BY1000 | L |
| ACS880-04F-880A-5 | R11 | 880 | 1000 | 600 | Ferraz: A4BY1000 | L |
| $U_N = 600\text{ V}$ | | | | | | |
| ACS880-04F-329A-7 | R11 | 329 | 500 | 600 | Bussmann: JJS-500 | T |
| ACS880-04F-369A-7 | R11 | 369 | 500 | 600 | Bussmann: JJS-500 | T |
| ACS880-04F-429A-7 | R11 | 429 | 500 | 600 | Bussmann: JJS-500 | T |
| ACS880-04F-470A-7 | R11 | 470 | 600 | 600 | Bussmann: JJS-600 | T |
| ACS880-04F-522A-7 | R11 | 522 | 600 | 600 | Bussmann: JJS-600 | T |
| ACS880-04F-590A-7 | R11 | 590 | 800 | 600 | Ferraz: A4BY800 | L |
| ACS880-04F-650A-7 | R11 | 650 | 800 | 600 | Ferraz: A4BY800 | L |
| ACS880-04F-721A-7 | R11 | 721 | 800 | 600 | Ferraz: A4BY800 | L |

—
aR fuses

ACS880-04FXT, ultrarapid (aR) fuses

| Type designation | Frame size | Input current (A) | Nominal current (A) | I^2t (A ² s) | Voltage rating (V) | Bussmann type Type DIN 43653 With trip indicator (Without trip indicator) | Size |
|---------------------------------|------------|----------------------|------------------------|------------------------------|-----------------------|--|------|
| $U_N = 400 V$ | | | | | | | |
| ACS880-04FXT-1008A-3 | 2xR11 | 1008 | 1000 | 945 000 | 690 | 170M6064(170M6014) | 3 |
| ACS880-04FXT-1188A-3 | 2xR11 | 1188 | 1000 | 945 000 | 690 | 170M6064(170M6014) | 3 |
| ACS880-04FXT-1330A-3 | 2xR11 | 1330 | 1250 | 1 950 000 | 690 | 170M6066(170M6016) | 3 |
| ACS880-04FXT-1610A-3 | 2xR11 | 1610 | 1600 | 3 900 000 | 690 | 170M6069(170M6019) | 3 |
| $U_N = 500 V$ | | | | | | | |
| ACS880-04FXT-1008A-5 | 2xR11 | 1008 | 1000 | 945 000 | 690 | 170M6064(170M6014) | 3 |
| ACS880-04FXT-1158A-5 | 2xR11 | 1158 | 1000 | 945 000 | 690 | 170M6064(170M6014) | 3 |
| ACS880-04FXT-1310A-5 | 2xR11 | 1310 | 1250 | 1 950 000 | 690 | 170M6066(170M6016) | 3 |
| ACS880-04FXT-1610A-5 | 2xR11 | 1610 | 1600 | 3 900 000 | 690 | 170M6069(170M6019) | 3 |
| $U_N = 690 V$ | | | | | | | |
| ACS880-04FXT-0808A-7 | 2xR11 | 808 | 1000 | 945 000 | 690 | 170M6064(170M6014) | 3 |
| ACS880-04FXT-0960A-7 | 2xR11 | 960 | 1250 | 1 950 000 | 690 | 170M6066(170M6016) | 3 |
| ACS880-04FXT-1080A-7 | 2xR11 | 1080 | 1400 | 2 450 000 | 690 | 170M6067(170M6017) | 3 |
| ACS880-04FXT-1320A-7 | 2xR11 | 1320 | 1500 | 3 100 000 | 690 | 170M6068(170M6018) | 3 |

—
UL fuses

ACS880-04FXT

| Type designation | Frame size | Input current (A) | Nominal current (A) | Voltage rating (V) | Type | UL class |
|---------------------------------|------------|----------------------|------------------------|-----------------------|-------------------|----------|
| $U_N = 400 V$ | | | | | | |
| ACS880-04FXT-1008A-3 | 2xR11 | 1008 | 800 | 600 | Ferraz: A4BY800 | L |
| ACS880-04FXT-1188A-3 | 2xR11 | 1188 | 800 | 600 | Ferraz: A4BY800 | L |
| ACS880-04FXT-1330A-3 | 2xR11 | 1330 | 800 | 600 | Ferraz: A4BY800 | L |
| ACS880-04FXT-1610A-3 | 2xR11 | 1610 | 1000 | 600 | Ferraz: A4BY1000 | L |
| $U_N = 480 V$ | | | | | | |
| ACS880-04FXT-1008A-5 | 2xR11 | 1008 | 800 | 600 | Ferraz: A4BY800 | L |
| ACS880-04FXT-1158A-5 | 2xR11 | 1158 | 800 | 600 | Ferraz: A4BY800 | L |
| ACS880-04FXT-1310A-5 | 2xR11 | 1310 | 800 | 600 | Ferraz: A4BY800 | L |
| ACS880-04FXT-1610A-5 | 2xR11 | 1610 | 1000 | 600 | Ferraz: A4BY1000 | L |
| $U_N = 575 V$ | | | | | | |
| ACS880-04FXT-0808A-7 | 2xR11 | 808 | 500 | 600 | Bussmann: JJS-500 | T |
| ACS880-04FXT-0960A-7 | 2xR11 | 960 | 600 | 600 | Bussmann: JJS-600 | T |
| ACS880-04FXT-1080A-7 | 2xR11 | 1080 | 800 | 600 | Ferraz: A4BY800 | L |
| ACS880-04FXT-1320A-7 | 2xR11 | 1320 | 800 | 600 | Ferraz: A4BY800 | L |

aR fuses

ACS880-11, ACS880-31

| Type designation ACS880-11- ACS880-31- | Frame size | Input current (A) | Nominal current (A) | I^2t (A ² s) | Voltage rating (V) | Bussmann type | Type DIN43653 stud-mount |
|--|---------------|-------------------------|---------------------------|------------------------------|--------------------------|---------------|--------------------------------|
| $U_N = 400\text{ V}$ | | | | | | | |
| 09A4-3 | R3 | 8 | 25 | 130 | 690 | 170M1311 | 000 |
| 12A6-3 | R3 | 10 | 25 | 130 | 690 | 170M1311 | 000 |
| 017A-3 | R3 | 14 | 25 | 130 | 690 | 170M1311 | 000 |
| 025A-3 | R3 | 20 | 32 | 270 | 690 | 170M1312 | 000 |
| 032A-3 | R6 | 27 | 40 | 460 | 690 | 170M1313 | 000 |
| 038A-3 | R6 | 33 | 63 | 1450 | 690 | 170M1315 | 000 |
| 045A-3 | R6 | 40 | 80 | 2550 | 690 | 170M1316 | 000 |
| 061A-3 | R6 | 51 | 80 | 2550 | 690 | 170M1316 | 000 |
| 072A-3 | R6 | 63 | 100 | 4650 | 690 | 170M1317 | 000 |
| 087A-3 | R6 | 76 | 125 | 8500 | 690 | 170M1318 | 000 |
| 105A-3 | R8 | 88 | 160 | 16000 | 690 | 170M1319 | 000 |
| 145A-3 | R8 | 120 | 200 | 28000 | 690 | 170M1320 | 000 |
| 169A-3 | R8 | 144 | 250 | 42000 | 690 | 170M2618 | 00 |
| 206A-3 | R8 | 176 | 315 | 68500 | 690 | 170M2619 | 00 |
| $U_N = 500\text{ V}$ | | | | | | | |
| 07A6-5 | R3 | 5.8 | 10 | 25.5 | 690 | 170M1308 | 000 |
| 11A0-5 | R3 | 7.8 | 16 | 48 | 690 | 170M1309 | 000 |
| 014A-5 | R3 | 10.6 | 25 | 130 | 690 | 170M1311 | 000 |
| 021A-5 | R3 | 15.6 | 25 | 130 | 690 | 170M1311 | 000 |
| 027A-5 | R6 | 21.3 | 40 | 460 | 690 | 170M1313 | 000 |
| 034A-5 | R6 | 26.2 | 63 | 1450 | 690 | 170M1315 | 000 |
| 040A-5 | R6 | 31.2 | 63 | 1450 | 690 | 170M1315 | 000 |
| 052A-5 | R6 | 40.1 | 80 | 2550 | 690 | 170M1316 | 000 |
| 065A-5 | R6 | 49.5 | 100 | 4650 | 690 | 170M1317 | 000 |
| 077A-5 | R6 | 60.2 | 125 | 8500 | 690 | 170M1318 | 000 |
| 101A-5 | R8 | 71 | 160 | 16000 | 690 | 170M1319 | 000 |
| 124A-5 | R8 | 96 | 200 | 28000 | 690 | 170M1320 | 000 |
| 156A-5 | R8 | 115 | 250 | 42000 | 690 | 170M2618 | 00 |
| 180A-5 | R8 | 141 | 315 | 68500 | 690 | 170M2619 | 00 |

aR fuses

ACS880-11, ACS880-31

| Type designation ACS880-11- ACS880-31- | Frame size | Input current (A) | Nominal current (A) | I^2t (A ² s) | Voltage rating (V) | Bussmann type | Type DIN43620 blade style |
|--|---------------|-------------------------|---------------------------|------------------------------|--------------------------|---------------|---------------------------------|
| $U_N = 400\text{ V}$ | | | | | | | |
| 09A4-3 | R3 | 8 | 25 | 130 | 690 | 170M1561 | 000 |
| 12A6-3 | R3 | 10 | 25 | 130 | 690 | 170M1561 | 000 |
| 017A-3 | R3 | 14 | 40 | 460 | 690 | 170M1563 | 000 |
| 025A-3 | R3 | 20 | 40 | 460 | 690 | 170M1563 | 000 |
| 032A-3 | R6 | 27 | 63 | 1450 | 690 | 170M1565 | 000 |
| 038A-3 | R6 | 33 | 63 | 1450 | 690 | 170M1565 | 000 |
| 045A-3 | R6 | 40 | 80 | 2550 | 690 | 170M1566 | 000 |
| 061A-3 | R6 | 51 | 100 | 4650 | 690 | 170M1567 | 000 |
| 072A-3 | R6 | 63 | 125 | 8500 | 690 | 170M1568 | 000 |
| 087A-3 | R6 | 76 | 160 | 16000 | 690 | 170M1569 | 000 |
| 105A-3 | R8 | 88 | 315 | 46500 | 690 | 170M3817 | 1 |
| 145A-3 | R8 | 120 | 315 | 46500 | 690 | 170M3817 | 1 |
| 169A-3 | R8 | 144 | 450 | 105000 | 690 | 170M5809 | 2 |
| 206A-3 | R8 | 176 | 500 | 145000 | 690 | 170M5810 | 2 |
| $U_N = 500\text{ V}$ | | | | | | | |
| 07A6-5 | R3 | 5.8 | 25 | 130 | 690 | 170M1561 | 000 |
| 11A0-5 | R3 | 7.8 | 25 | 130 | 690 | 170M1561 | 000 |
| 014A-5 | R3 | 10.6 | 40 | 460 | 690 | 170M1563 | 000 |
| 021A-5 | R3 | 15.6 | 40 | 460 | 690 | 170M1563 | 000 |
| 027A-5 | R6 | 21.3 | 63 | 1450 | 690 | 170M1565 | 000 |
| 034A-5 | R6 | 26.2 | 63 | 1450 | 690 | 170M1565 | 000 |
| 040A-5 | R6 | 31.2 | 80 | 2550 | 690 | 170M1566 | 000 |
| 052A-5 | R6 | 40.1 | 100 | 4650 | 690 | 170M1567 | 000 |
| 065A-5 | R6 | 49.5 | 125 | 8500 | 690 | 170M1568 | 000 |
| 077A-5 | R6 | 60.2 | 160 | 16000 | 690 | 170M1569 | 000 |
| 101A-5 | R8 | 71 | 250 | 28500 | 690 | 170M3816 | 1 |
| 124A-5 | R8 | 96 | 315 | 46500 | 690 | 170M3817 | 1 |
| 156A-5 | R8 | 115 | 400 | 74000 | 690 | 170M5808 | 2 |
| 180A-5 | R8 | 141 | 500 | 155000 | 690 | 170M5810 | 2 |

—
gG fuses *)

ACS880-11, ACS880-31

| Type designation ACS880-11- ACS880-31- | Frame size | Input current (A) | Nominal current (A) | I^2t (A ² s) | Voltage rating (V) | Bussmann type | Type DIN43620 blade style |
|--|---------------|-------------------------|---------------------------|------------------------------|--------------------------|---------------|---------------------------------|
| $U_N = 400 V$ | | | | | | | |
| 09A4-3 | R3 | 8.0 | 16 | 700 | 500 | OFAF000H16 | 000 |
| 12A6-3 | R3 | 10.0 | 16 | 700 | 500 | OFAF000H16 | 000 |
| 017A-3 | R3 | 14.0 | 25 | 2500 | 500 | OFAF000H25 | 000 |
| 025A-3 | R3 | 20.0 | 32 | 4500 | 500 | OFAF000H32 | 000 |
| 032A-3 | R6 | 27.0 | 40 | 7700 | 500 | OFAF000H40 | 000 |
| 038A-3 | R6 | 33.0 | 50 | 15400 | 500 | OFAF000H50 | 000 |
| 045A-3 | R6 | 40.0 | 63 | 21300 | 500 | OFAF000H63 | 000 |
| 061A-3 | R6 | 51.0 | 80 | 37000 | 500 | OFAF000H80 | 000 |
| 072A-3 | R6 | 63.0 | 100 | 63600 | 500 | OFAF000H100 | 000 |
| 087A-3 | R6 | 76.0 | 100 | 63600 | 500 | OFAF000H100 | 000 |
| $U_N = 500 V$ | | | | | | | |
| 07A6-5 | R3 | 5.8 | 16 | 700 | 500 | OFAF000H16 | 000 |
| 11A0-5 | R3 | 7.8 | 16 | 700 | 500 | OFAF000H16 | 000 |
| 014A-5 | R3 | 10.6 | 25 | 2500 | 500 | OFAF000H25 | 000 |
| 021A-5 | R3 | 15.6 | 32 | 4500 | 500 | OFAF000H32 | 000 |
| 027A-5 | R6 | 21.3 | 40 | 7700 | 500 | OFAF000H40 | 000 |
| 034A-5 | R6 | 26.2 | 50 | 15400 | 500 | OFAF000H50 | 000 |
| 040A-5 | R6 | 31.2 | 63 | 21300 | 500 | OFAF000H63 | 000 |
| 052A-5 | R6 | 40.1 | 80 | 37000 | 500 | OFAF000H80 | 000 |
| 065A-5 | R6 | 49.5 | 100 | 63600 | 500 | OFAF000H100 | 000 |
| 077A-5 | R6 | 60.2 | 100 | 63600 | 500 | OFAF000H100 | 000 |

*) gG fuses are not allowed for frame 8

—
UL fuses

ACS880-11, ACS880-31

| Type designation ACS880-11- ACS880-31- | Frame size | Input current (A) | Nominal current (A) | Voltage rating (V) | Bussmann type | UL class |
|--|---------------|-------------------------|---------------------------|--------------------------|---------------|----------|
| $U_N = 400 V$ | | | | | | |
| 07A6-5 | R3 | 5.8 | 15 | 600 | JJS-15 | T |
| 11A0-5 | R3 | 7.8 | 20 | 600 | JJS-20 | T |
| 014A-5 | R3 | 10.6 | 25 | 600 | JJS-25 | T |
| 021A-5 | R3 | 15.6 | 35 | 600 | JJS-35 | T |
| 027A-5 | R6 | 21.3 | 40 | 600 | JJS-40 | T |
| 034A-5 | R6 | 26.2 | 50 | 600 | JJS-50 | T |
| 040A-5 | R6 | 31.2 | 60 | 600 | JJS-60 | T |
| 052A-5 | R6 | 40.1 | 80 | 600 | JJS-80 | T |
| 065A-5 | R6 | 49.5 | 90 | 600 | JJS-90 | T |
| 077A-5 | R6 | 60.2 | 110 | 600 | JJS-110 | T |
| 101A-5 | R8 | 74 | 150 | 600 | JJS-150 | T |
| 124A-5 | R8 | 100 | 200 | 600 | JJS-200 | T |
| 156A-5 | R8 | 120 | 225 | 600 | JJS-225 | T |
| 180A-5 | R8 | 147 | 300 | 600 | JJS-300 | T |

aR fuses
ACS880-14, ACS880-34

| Type designation ACS880-14- ACS880-34- | Frame size | Input current (A) | Nominal current (A) | I^2t (A ² s) | Voltage rating (V) | Bussmann type | Size |
|--|---------------|-------------------------|---------------------------|------------------------------|--------------------------|---------------|------|
| $U_N = 400\text{ V}$ | | | | | | | |
| 246A-3 | R11 | 212 | 400 | 74000 | 690 | 170M5408 | 2 |
| 293A-3 | R11 | 257 | 500 | 145000 | 690 | 170M5410 | 2 |
| 363A-3 | R11 | 321 | 630 | 210000 | 690 | 170M6410 | 3 |
| 442A-3 | R11 | 401 | 700 | 300000 | 690 | 170M6411 | 3 |
| 505A-3 | R11 | 401 | 800 | 465000 | 690 | 170M6412 | 3 |
| 585A-3 | R11 | 505 | 1000 | 945000 | 690 | 170M6414 | 3 |
| 650A-3 | R11 | 569 | 1000 | 945000 | 690 | 170M6414 | 3 |
| $U_N = 500\text{ V}$ | | | | | | | |
| 240A-5 | R11 | 169 | 315 | 42000 | 690 | 170M4410 | 1 |
| 260A-5 | R11 | 205 | 400 | 74000 | 690 | 170M5408 | 2 |
| 302A-5 | R11 | 249 | 500 | 145000 | 690 | 170M5410 | 2 |
| 361A-5 | R11 | 257 | 630 | 210000 | 690 | 170M6410 | 3 |
| 414A-5 | R11 | 321 | 700 | 300000 | 690 | 170M6411 | 3 |
| 460A-5 | R11 | 404 | 700 | 300000 | 690 | 170M6411 | 3 |
| 503A-5 | R11 | 455 | 800 | 465000 | 690 | 170M6412 | 3 |
| $U_N = 690\text{ V}$ | | | | | | | |
| 142A-7 | R11 | 123 | 250 | 21000 | 690 | 170M4409 | 1 |
| 174A-7 | R11 | 149 | 315 | 42000 | 690 | 170M4410 | 1 |
| 210A-7 | R11 | 186 | 400 | 74000 | 690 | 170M5408 | 2 |
| 271A-7 | R11 | 232 | 500 | 145000 | 690 | 170M5410 | 2 |
| 330A-7 | R11 | 293 | 630 | 210000 | 690 | 170M6410 | 3 |
| 370A-7 | R11 | 330 | 700 | 300000 | 690 | 170M6411 | 3 |
| 430A-7 | R11 | 375 | 700 | 300000 | 690 | 170M6411 | 3 |

UL fuses

aR fuses are UL recognized and can be used in UL installations with ACS880-14 and ACS880-34.

aR fuses

ACS880-17, ACS880-37

| Type designation ACS880-17- ACS880-37- | Frame size | Input current (A) | Nominal current (A) | I^2t (A ² s) | Voltage rating (V) | Manufacturer | Type | Size |
|--|---------------|-------------------------|---------------------------|------------------------------|--------------------------|--------------|----------------|------|
| $U_N = 400\text{ V}$ | | | | | | | | |
| 0105A-3 | R8 | 88 | 160 | 8250 | 690 | Bussmann | 170M3814D | 1 |
| 0145A-3 | R8 | 120 | 250 | 31000 | 690 | Bussmann | 170M3816D | 1 |
| 0169A-3 | R8 | 144 | 250 | 31000 | 690 | Bussmann | 170M3816D | 1 |
| 0206A-3 | R8 | 176 | 315 | 52000 | 690 | Bussmann | 170M3817D | 1 |
| 0293A-3 | R11 | 257 | 500 | 145000 | 690 | Bussmann | 170M5410 | 2 |
| | | | | 160000 | 690 | Mersen | SC32AR69V500TF | 2 |
| 0363A-3 | R11 | 321 | 630 | 210000 | 690 | Bussmann | 170M6410 | 3 |
| | | | | 315000 | 690 | Mersen | SC32AR69V630TF | 2 |
| 0442A-3 | R11 | 401 | 700 | 300000 | 690 | Bussmann | 170M6411 | 3 |
| | | | | 442000 | 690 | Mersen | SC32AR69V700TF | 2 |
| 0505A-3 | R11 | 401 | 800 | 465000 | 690 | Bussmann | 170M6412 | 3 |
| | | | | 660000 | 690 | Mersen | SC32AR69V800TF | 2 |
| 0585A-3 | R11 | 505 | 900 | 670000 | 690 | Bussmann | 170M6413 | 3 |
| | | | | 805000 | 690 | Mersen | SC33AR69V900TF | 3 |
| 0650A-3 | R11 | 569 | 1000 | 945000 | 690 | Bussmann | 170M6414 | 3 |
| | | | | 1070000 | 690 | Mersen | SC33AR69V10CTF | 3 |
| $U_N = 500\text{ V}$ | | | | | | | | |
| 0101A-5 | R8 | 71 | 160 | 8250 | 690 | Bussmann | 170M3814D | 1 |
| 0124A-5 | R8 | 96 | 250 | 31000 | 690 | Bussmann | 170M3816D | 1 |
| 0156A-5 | R8 | 115 | 250 | 31000 | 690 | Bussmann | 170M3816D | 1 |
| 0180A-5 | R8 | 141 | 315 | 52000 | 690 | Bussmann | 170M3817D | 1 |
| 0260A-5 | R11 | 205 | 400 | 74000 | 690 | Bussmann | 170M5408 | 2 |
| 0361A-5 | R11 | 257 | 630 | 210000 | 690 | Bussmann | 170M6410 | 3 |
| | | | | 315000 | 690 | Mersen | SC32AR69V630TF | 2 |
| 0414A-5 | R11 | 321 | 700 | 300000 | 690 | Bussmann | 170M6411 | 3 |
| | | | | 442000 | 690 | Mersen | SC32AR69V700TF | 2 |
| 0460A-5 | R11 | 404 | 700 | 300000 | 690 | Bussmann | 170M6411 | 3 |
| | | | | 442000 | 690 | Mersen | SC32AR69V700TF | 2 |
| 0503A-5 | R11 | 455 | 800 | 465000 | 690 | Bussmann | 170M6412 | 3 |
| | | | | 660000 | 690 | Mersen | SC32AR69V800TF | 2 |
| $U_N = 690\text{ V}$ | | | | | | | | |
| 0174A-7 | R11 | 149 | 400 | 74000 | 690 | Bussmann | 170M5408 | 2 |
| 0210A-7 | R11 | 186 | 400 | 74000 | 690 | Bussmann | 170M5408 | 2 |
| 0271A-7 | R11 | 232 | 500 | 105000 | 690 | Bussmann | 170M5410 | 2 |
| | | | | 160000 | 690 | Mersen | SC32AR69V500TF | 2 |
| 0330A-7 | R11 | 293 | 630 | 210000 | 690 | Bussmann | 170M6410 | 3 |
| | | | | 315000 | 690 | Mersen | SC32AR69V630TF | 2 |
| 0370A-7 | R11 | 330 | 630 | 21000 | 690 | Bussmann | 170M6410 | 3 |
| | | | | 315000 | 690 | Mersen | SC32AR69V630TF | 2 |
| 0430A-7 | R11 | 375 | 700 | 300000 | 690 | Bussmann | 170M6411 | 3 |
| | | | | 442000 | 690 | Mersen | SC32AR69V700TF | 2 |

—
UL fuses

ACS880-17, ACS880-37

| Type designation ACS880-17- ACS880-37- | Frame size | Input current (A) | Nominal current (A) | Voltage rating (V) | Bussmann type | UL class / Size |
|--|---------------|-------------------------|---------------------------|--------------------------|---------------|-----------------|
| $U_N = 400\text{ V}$ | | | | | | |
| 0105A-3 | R8 | 88 | 250 | 600 | DFJ-250 | Class J |
| 0145A-3 | R8 | 120 | 250 | 600 | DFJ-250 | Class J |
| 0169A-3 | R8 | 144 | 250 | 600 | DFJ-250 | Class J |
| 0206A-3 | R8 | 176 | 300 | 600 | DFJ-300 | Class J |
| 0293A-3 | R11 | 257 | 500 | 690 | 170M5410 | 2 |
| 0363A-3 | R11 | 321 | 630 | 690 | 170M6410 | 3 |
| 0442A-3 | R11 | 401 | 700 | 690 | 170M6411 | 3 |
| 0505A-3 | R11 | 401 | 800 | 690 | 170M6412 | 3 |
| 0585A-3 | R11 | 505 | 1000 | 690 | 170M6414 | 3 |
| 0650A-3 | R11 | 569 | 1000 | 690 | 170M6414 | 3 |
| $U_N = 480\text{ V}$ | | | | | | |
| 0101A-5 | R8 | 74 | 250 | 600 | DFJ-250 | Class J |
| 0124A-5 | R8 | 100 | 250 | 600 | DFJ-250 | Class J |
| 0156A-5 | R8 | 120 | 250 | 600 | DFJ-250 | Class J |
| 0180A-5 | R8 | 147 | 300 | 600 | DFJ-300 | Class J |
| 0260A-5 | R11 | 205 | 400 | 600 | 170M5408 | 2 |
| 0302A-5 | R11 | 239 | 500 | 690 | 170M5410 | 2 |
| 0361A-5 | R11 | 257 | 630 | 690 | 170M6410 | 3 |
| 0414A-5 | R11 | 321 | 700 | 690 | 170M6411 | 3 |
| 0460A-5 | R11 | 404 | 700 | 690 | 170M6411 | 3 |
| 0503A-5 | R11 | 455 | 800 | 690 | 170M6412 | 3 |
| $U_N = 600\text{ V}$ | | | | | | |
| 0174A-7 | R11 | 146 | 315 | 600 | 170M4410 | 1 |
| 0210A-7 | R11 | 166 | 400 | 690 | 170M5408 | 2 |
| 0271A-7 | R11 | 208 | 500 | 690 | 170M5410 | 2 |
| 0330A-7 | R11 | 250 | 630 | 690 | 170M6410 | 3 |
| 0370A-7 | R11 | 291 | 700 | 690 | 170M6411 | 3 |
| 0430A-7 | R11 | 375 | 700 | 690 | 170M6411 | 3 |

Circuit breaker table

| ACS380 | | |
|---|------------|---------------------------------------|
| Type designation ACS380-04- | Frame size | Miniature circuit breaker ABB type |
| 1-phase $U_N = 200...240$ V (200, 208, 220, 230, 240 V) | | |
| 02A4-1 | R0 | S 201P-B 10 NA |
| 03A7-1 | R0 | S 201P-B 10 NA |
| 04A8-1 | R1 | S 201P-B 16 NA |
| 06A9-1 | R1 | S 201P-B 20 NA |
| 07A8-1 | R1 | S 201P-B 25 NA |
| 09A8-1 | R2 | S 201P-B 25 NA |
| 12A2-1 | R2 | S 201P-B 32 NA |

| ACS380 | | |
|--|------------|---------------------------------------|
| Type designation ACS380-04xx- | Frame size | Miniature circuit breaker ABB type |
| 3-phase $U_N = 380...480$ V (380, 400, 415, 440, 460, 480 V) | | |
| 01A8-4 | R0 | S 203P-B 4 |
| 02A6-4 | R1 | S 203P-B 6 |
| 03A3-4 | R1 | S 203P-B 6 |
| 04A0-4 | R1 | S 203P-B 8 |
| 05A6-4 | R1 | S 203P-B 10 |
| 07A2-4 | R1 | S 203P-B 16 |
| 09A4-4 | R1 | S 203P-B 16 |
| 12A6-4 | R2 | S 203P-B 25 |
| 17A0-4 | R3 | S 203P-B 32 |
| 25A0-4 | R3 | S 203P-B 50 |
| 032A-4 | R4 | S 803S-B 100 |
| 038A-4 | R4 | S 803S-B 100 |
| 045A-4 | R4 | S 803S-B 100 |
| 050A-4 | R4 | S 803S-B 100 |

| ACS480 | | | |
|---|------------|---------------------------------------|-----------------------|
| IEC type ACS480-04- | Frame size | Miniature circuit breaker ABB type | Network SC *) (kA) |
| 3-phase $U_N = 400$ V | | | |
| 02A7-4 | R1 | S 203P-B 6 | 5 |
| 03A4-4 | R1 | S 203P-B 6 | 5 |
| 04A1-4 | R1 | S 203P-B 8 | 5 |
| 05A7-4 | R1 | S 203P-B 10 | 5 |
| 07A3-4 | R1 | S 203P-B 16 | 5 |
| 09A5-4 | R1 | S 203P-B 16 | 5 |
| 12A7-4 | R2 | S 203P-B 25 | 5 |
| 018A-4 | R3 | S 203P-B 32 | 5 |
| 026A-4 | R3 | S 203P-B 50 | 5 |
| 033A-4 | R4 | S 203P-B 63 | 5 |
| 039A-4 | R4 | S 803S-B 80 | 5 |
| 046A-4 | R4 | S 803-B 100 | 5 |
| 050A-4 | R4 | S 803-B 100 | 5 |

*) Maximum allowed rated conditional short-circuit current (IEC 61800-5-1) of the electrical power network.

| ACS580-01 | | | | | | | | |
|---|------------|--------------------|---------------------------|--|-----------------------------|-------------------------|----------------------------|--------------------------------|
| Type designation ACS580-01- | Frame size | Aux. Contr. Volt.: | Miniature circuit breaker | T_{max} moulded case circuit breaker | | Switch-disconnector | | Main contactor (≤ 40 °C) |
| | | | | ABB type | ABB type | Main Switch ABB type | Main Switch UL ABB type | |
| 3-phase, $U_N = 400$ or 480 V (380...415 V, 440...480 V) | | | | | | | | |
| 02A7-4 | R1 | 230/115 | S 203P-B/C/Z 10 | - | - | OT16F3 | OT16F3 | AF09-30-22-13 |
| 03A4-4 | R1 | 230/115 | S 203P-B/C/Z 10 | - | - | OT16F3 | OT16F3 | AF09-30-22-13 |
| 04A1-4 | R1 | 230/115 | S 203P-B/C/Z 10 | - | - | OT16F3 | OT16F3 | AF09-30-22-13 |
| 05A7-4 | R1 | 230/115 | S 203P-B/C/Z 10 | - | - | OT16F3 | OT16F3 | AF09-30-22-13 |
| 07A3-4 | R1 | 230/115 | S 203P-B/C/Z 10 | - | - | OT16F3 | OT16F3 | AF09-30-22-13 |
| 09A5-4 | R1 | 230/115 | S 203P-B/C/Z 10 | - | - | OT16F3 | OT16F3 | AF09-30-22-13 |
| 12A7-4 | R1 | 230/115 | S 203P-B/C/Z 16 | - | - | OT16F3 | OT16F3 | AF09-30-22-13 |
| 018A-4 | R2 | 230/115 | S 203P-B/C/Z 20 | - | - | OT25F3 | OT25F3 | AF09-30-22-13 |
| 026A-4 | R2 | 230/115 | S 203P-B/C/Z 25 | - | - | OT25F3 | OT25F3 | AF12-30-22-13 |
| 033A-4 | R3 | 230/115 | S 203P-B/C/Z 32 | - | - | OT63F3 | OT63F3 | AF26-30-22-13 |
| 039A-4 | R3 | 230/115 | S 203P-B/C/Z 40 | - | - | OT63F3 | OT63F3 | AF52-30-22-13 |
| 046A-4 | R3 | 230/115 | S 203P-B/C/Z 50 | - | - | OT63F3 | OT63F3 | AF52-30-22-13 |
| 062A-4 | R4 | 230/115 | S 803 S-B/C 75 | - | - | OT100F | OT100F | AF52-30-22-13 |
| 073A-4 | R4 | 230/115 | - | 1SDA067918R1 | Prospective SC current 65kA | OT100F | OT100F | AF52-30-22-13 |
| 088A-4 | R5 | 230/115 | - | 1SDA067918R1 | Prospective SC current 65kA | OT160EV | OT200U | AF65-30-22-13 |
| 106A-4 | R5 | 230/115 | - | 1SDA068555R1 | Prospective SC current 65kA | OT160EV | OT200U | AF146-30-22-13 |
| 145A-4 | R6 | 230/115 | - | 1SDA068555R1 | Prospective SC current 65kA | OT160EV | OT200U | AF146-30-22-13 |
| 169A-4 | R7 | 230/115 | - | 1SDA068555R1 | Prospective SC current 65kA | OT250E | OT400U | AF146-30-22-13 |
| 206A-4 | R7 | 230/115 | - | 1SDA054141R1 | Prospective SC current 65kA | OT250E | OT400U | AF146-30-22-13 |
| 246A-4 | R8 | 230/115 | - | 1SDA054365R1 | Prospective SC current 65kA | OT400E | OT400U | AF265-30-22-13 |
| 293A-4 | R8 | 230/115 | - | 1SDA054420R1 | Prospective SC current 65kA | OT400E | OT400U | AF265-30-22-13 |
| 363A-4 | R9 | 230/115 | - | 1SDA054420R1 | Prospective SC current 65kA | OT630E | OT600U | AF400-30-22-70 |
| 430A-4 | R9 | 230/115 | - | 1SDA054420R1 | Prospective SC current 65kA | OT630E | OT600U | AF400-30-22-70 |

| ACS580-04 | | | | | | | | |
|---|------------|--------------------|---------------------------|--|---|-------------------------|----------------------------|--------------------------------|
| Type designation ACS580-04- | Frame size | Aux. Contr. Volt.: | Miniature circuit breaker | T_{max} moulded case circuit breaker | | Switch-disconnector | | Main contactor (≤ 40 °C) |
| | | | | ABB type | ABB type | Main Switch ABB type | Main Switch UL ABB type | |
| $U_N = 380...480$ V (380, 400, 415 V) | | | | | | | | |
| 505A-4 | R10 | 230/115 | - | 1SDA054412R1 | (T5H 630 PR221DS-LS/ $I_n = 630$ 3p F F) | OT630E | OT600U | - |
| 585A-4 | R10 | 230/115 | - | 1SDA069428R1 | (T6V 800 PR221DS-LS/ $I_n = 800$ 3p F F) | OT630E | OT600U | - |
| 650A-4 | R10 | 230/115 | - | 1SDA069428R1 | (T6V 800 PR221DS-LS/ $I_n = 800$ 3p F F) | OT800E | OT800U | - |
| 725A-4 | R11 | 230/115 | - | 1SDA062770R1 | (T7H 1000 PR231/P LS/ $I_n = 1000A$ 3p F F) | OT800E | OT800U | - |
| 820A-4 | R11 | 230/115 | - | 1SDA062770R1 | (T7H 1000 PR231/P LS/ $I_n = 1000A$ 3p F F) | OT1000E | OT1200U | - |
| 880A-4 | R11 | 230/115 | - | 1SDA062770R1 | (T7H 1000 PR231/P LS/ $I_n = 1000A$ 3p F F) | OT1000E | OT1200U | - |

| ACS880-01 | | | | | | | |
|--------------------------------|------------|--------------------|---------------------------|--|---------------------|----------------|--------------------------------|
| Type designation ACS880-01- | Frame size | Aux. Contr. Volt.: | Miniature circuit breaker | T_{max} moulded case circuit breaker | Switch-disconnector | | Main contactor (≤ 40 °C) |
| | | | | | Main Switch | Main Switch UL | |
| | | | ABB type | ABB type | ABB type | ABB type | ABB type |
| $U_N = 230$ V | | | | | | | |
| 04A6-2 | R1 | 230/115 | S 203 M/P-B/C 10 | - | OS32GD | - | AF09-30-22-13 |
| 06A6-2 | R1 | 230/115 | S 203 M/P-B/C 10 | - | OS32GD | - | AF09-30-22-13 |
| 07A5-2 | R1 | 230/115 | S 203 M/P-B/C 10 | - | OS32GD | - | AF09-30-22-13 |
| 10A6-2 | R1 | 230/115 | S 203 M/P-B/C 16 | - | OS32GD | - | AF09-30-22-13 |
| 16A8-2 | R2 | 230/115 | S 203 M/P-B/C 16 | - | OS32GD | - | AF09-30-22-13 |
| 24A3-2 | R2 | 230/115 | S 203 M/P-B/C 32 | - | OS32GD | - | AF09-30-22-13 |
| 031A-2 | R3 | 230/115 | S 203 M/P-B/C 50 | - | OS63GD | - | AF26-30-22-13 |
| 046A-2 | R4 | 230/115 | S 803 S-B/C 75 | - | - | - | AF30-30-22-13 |
| 061A-2 | R4 | 230/115 | S 803 S-B/C 80 | - | - | - | AF50-30-22-70 |
| 075A-2 | R5 | 230/115 | S 803 S-B/C 125 | - | - | - | AF50-30-22-70 |
| 087A-2 | R5 | 230/115 | S 803 S-B/C 125 | - | - | - | AF50-30-22-70 |
| 115A-2 | R6 | 230/115 | - | 1SDA067918R1 500 V: Prospective SC current 65 kA >500 V Prospective SC current 18 kA | - | - | AF75-30-22-70 |
| 145A-2 | R6 | 230/116 | - | 1SDA068555R1 500 V: Prospective SC current 65 kA >500 V Prospective SC current 20 kA | - | - | AF95-30-22-70 |
| 170A-2 | R7 | 230/117 | - | 1SDA068555R1 500 V: Prospective SC current 65 kA >500 V Prospective SC current 20 kA | - | - | AF145-30-22-70 |
| 206A-2 | R7 | 230/118 | - | 1SDA054141R1 500 V: Prospective SC current 65 kA >500 V Prospective SC current 35 kA | - | - | AF145-30-22-70 |
| 274A-2 | R8 | 230/119 | - | - | - | - | - |

| ACS880-01 | | | | | | | |
|--------------------------------|------------|--------------------|---------------------------|---|---------------------|----------------|--|
| Type designation ACS880-01- | Frame size | Aux. Contr. Volt.: | Miniature circuit breaker | T_{max} moulded case circuit breaker | Switch-disconnector | | Main contactor ($\leq 40^\circ\text{C}$) |
| | | | | | Main Switch | Main Switch UL | |
| | | | ABB type | ABB type | ABB type | ABB type | ABB type |
| $U_N = 400\text{ V}$ | | | | | | | |
| 02A4-3 | R1 | 230/115 | S 203 M/P-B/C 6 | - | OS32GD | - | AF09-30-22-13 |
| 03A3-3 | R1 | 230/115 | S 203 M/P-B/C 6 | - | OS32GD | - | AF09-30-22-13 |
| 04A0-3 | R1 | 230/115 | S 203 M/P-B/C 6 | - | OS32GD | - | AF09-30-22-13 |
| 05A6-3 | R1 | 230/115 | S 203 M/P-B/C 10 | - | OS32GD | - | AF09-30-22-13 |
| 07A2-3 | R1 | 230/115 | S 203 M/P-B/C 13 | - | OS32GD | - | AF09-30-22-13 |
| 09A4-3 | R1 | 230/115 | S 203 M/P-B/C 13 | - | OS32GD | - | AF09-30-22-13 |
| 12A6-3 | R1 | 230/115 | S 203 M/P-B/C 20 | - | OS32GD | - | AF09-30-22-13 |
| 017A-3 | R2 | 230/115 | S 203 M/P-B/C 25 | - | OS32GD | - | AF09-30-22-13 |
| 025A-3 | R2 | 230/115 | S 203 M/P-B/C 32 | - | OS63GD | - | AF12-30-22-13 |
| 032A-3 | R3 | 230/115 | S 203 M/P-B/C 50 | - | OS63GD | - | AF26-30-22-13 |
| 038A-3 | R3 | 230/115 | S 203 M/P-B/C 63 | - | OS63GD | - | AF26-30-22-13 |
| 045A-3 | R4 | 230/115 | S 803 S-B/C 63 | - | OS63GD | - | AF30-30-22-13 |
| 061A-3 | R4 | 230/115 | S 803 S-B/C 75 | - | OS125GD | - | AF50-30-22-70 |
| 072A-3 | R5 | 230/115 | S 803 S-B/C 125 | - | OS125GD | - | AF50-30-22-70 |
| 087A-3 | R5 | 230/115 | S 803 S-B/C 125 | - | OS125GD | - | AF50-30-22-70 |
| 105A-3 | R6 | 230/115 | - | 1SDA068555R1 (XT4 L 250 Ekip LS/I In = 250 3p F F) 500 V: Prospective SC current 65 kA >500 V Prospective SC current 20 kA | OS160GD | - | AF63-30-22-70 |
| 145A-3 | R6 | 230/116 | - | 1SDA068555R1 (XT4 L 250 Ekip LS/I In = 250 3p F F) 500 V: Prospective SC current 65 kA >500 V Prospective SC current 20 kA | OS250D12 | - | AF110-30-22-70 |
| 169A-3 | R7 | 230/117 | - | 1SDA068555R1 (XT4 L 250 Ekip LS/I In = 250 3p F F) 500 V: Prospective SC current 65 kA >500 V Prospective SC current 20 kA | OS250D12 | - | AF145-30-22-70 |
| 206A-2 | R7 | 230/118 | - | 1SDA054141R1 (T4 L 320 PR221DS-LS/I In = 320 3p F F) 500 V: Prospective SC current 65 kA >500 V Prospective SC current 35 kA | OS250D12 | - | AF145-30-22-70 |
| 246A-3 | R8 | 230/115 | - | - | OS400D12 | - | AF145-30-22-70 |
| 293A-3 | R8 | 230/115 | - | - | OS630D12 | - | AF210-30-22-70 |
| 363A-3 | R9 | 230/115 | - | - | OS630D12 | - | AF260-30-22-70 |
| 430A-3 | R9 | 230/115 | - | - | OS630D12 | - | AF300-30-22-70 |

| ACS880-01 | | | | | | | |
|--------------------------------|------------|--------------------|---------------------------|--|---------------------|----------------|--------------------------------|
| Type designation ACS880-01- | Frame size | Aux. Contr. Volt.: | Miniature circuit breaker | T_{max} moulded case circuit breaker | Switch-disconnector | | Main contactor (≤ 40 °C) |
| | | | | | Main Switch | Main Switch UL | |
| | | | ABB type | ABB type | ABB type | ABB type | ABB type |
| $U_N = 500$ V | | | | | | | |
| 02A1-5 | R1 | 230/115 | S 803 S-B/C 6 | - | OS32GD | - | AF09-30-22-13 |
| 03A0-5 | R1 | 230/115 | S 803 S-B/C 6 | - | OS32GD | - | AF09-30-22-13 |
| 03A4-5 | R1 | 230/115 | S 803 S-B/C 6 | - | OS32GD | - | AF09-30-22-13 |
| 04A8-5 | R1 | 230/115 | S 803 S-B/C 10 | - | OS32GD | - | AF09-30-22-13 |
| 05A2-5 | R1 | 230/115 | S 803 S-B/C 13 | - | OS32GD | - | AF09-30-22-13 |
| 07A6-5 | R1 | 230/115 | S 803 S-B/C 13 | - | OS32GD | - | AF09-30-22-13 |
| 11A0-5 | R1 | 230/115 | S 803 S-B/C 20 | - | OS32GD | - | AF09-30-22-13 |
| 014A-5 | R2 | 230/115 | S 803 S-B/C 25 | - | OS32GD | - | AF09-30-22-13 |
| 021A-5 | R2 | 230/115 | S 803 S-B/C 32 | - | OS32GD | - | AF09-30-22-13 |
| 027A-5 | R3 | 230/115 | S 803 S-B/C 50 | - | OS63GD | - | AF12-30-22-13 |
| 034A-5 | R3 | 230/115 | S 803 S-B/C 63 | - | OS63GD | - | AF26-30-22-13 |
| 040A-5 | R4 | 230/115 | S 803 S-B/C 63 | - | OS63GD | - | AF26-30-22-13 |
| 052A-5 | R4 | 230/115 | S 803 S-B/C 75 | - | OS63GD | - | AF50-30-22-70 |
| 065A-5 | R5 | 230/115 | S 803 S-B/C 125 | - | OS125GD | - | AF50-30-22-70 |
| 077A-5 | R5 | 230/115 | S 803 S-B/C 125 | - | OS125GD | - | AF50-30-22-70 |
| 096A-5 | R6 | 230/115 | - | 1SDA068555R1 500 V: Prospective SC current 65 kA >500 V Prospective SC current 20 kA | OS125GD | - | AF50-30-22-70 |
| 124A-5 | R6 | 230/115 | - | 1SDA068555R1 500 V: Prospective SC current 65 kA >500 V Prospective SC current 20 kA | OS160GD | - | AF75-30-22-70 |
| 156A-5 | R7 | 230/115 | - | 1SDA068555R1 500 V: Prospective SC current 65 kA >500 V Prospective SC current 20 kA | OS160GD | - | AF110-30-22-70 |
| 180A-5 | R7 | 230/115 | - | 1SDA054141R1 500 V: Prospective SC current 65 kA >500 V Prospective SC current 35 kA | OS250D12 | - | AF145-30-22-70 |
| 240A-5 | R8 | 230/115 | - | 1SDA054420R1 500 V: Prospective SC current 65 kA >500 V Prospective SC current 35 kA | OS250D12 | - | AF145-30-22-70 |
| 260A-5 | R8 | 230/115 | - | 1SDA054420R1 500 V: Prospective SC current 65 kA >500 V Prospective SC current 35 kA | OS400D12 | - | AF185-30-22-70 |
| 302A-5 | R9 | 230/115 | - | 1SDA054420R1 500 V: Prospective SC current 65 kA >500 V Prospective SC current 35 kA | OS400D12 | - | AF210-30-22-70 |
| 361A-5 | R9 | 230/115 | - | 1SDA054420R1 500 V: Prospective SC current 65 kA >500 V Prospective SC current 35 kA | OS630D12 | - | AF260-30-22-70 |
| 414A-5 | R9 | 230/115 | - | 1SDA054420R1 500 V: Prospective SC current 65 kA >500 V Prospective SC current 35 kA | OS630D12 | - | AF300-30-22-70 |

| ACS880-01 | | | | | | | |
|--------------------------------|------------|--------------------|---------------------------|---|-------------------------|----------------------------|--------------------------------|
| Type designation ACS880-01- | Frame size | Aux. Contr. Volt.: | Miniature circuit breaker | T_{max} moulded case circuit breaker | Switch-disconnector | | Main contactor (≤ 40 °C) |
| | | | ABB type | ABB type | Main Switch ABB type | Main Switch UL ABB type | ABB type |
| $U_N = 690$ V | | | | | | | |
| 07A4-7 | R3 | 230/115 | S 803 S-B/C 13 | – | OS32GD | – | AF09-30-22-13 |
| 09A9-7 | R3 | 230/115 | S 803 S-B/C 20 | – | OS32GD | – | AF09-30-22-13 |
| 14A3-7 | R3 | 230/115 | S 803 S-B/C 25 | – | OS32GD | – | AF09-30-22-13 |
| 019A-7 | R3 | 230/115 | S 803 S-B/C 32 | – | OS32GD | – | AF09-30-22-13 |
| 023A-7 | R3 | 230/115 | S 803 S-B/C 50 | – | OS32GD | – | AF09-30-22-13 |
| 027A-7 | R3 | 230/115 | S 803 S-B/C 63 | – | OS63GD | – | AF12-30-22-13 |
| 035A-7 | R5 | 230/115 | S 803 S-B/C 63 | – | OS63GD | – | AF26-30-22-13 |
| 042A-7 | R5 | 230/115 | S 803 S-B/C 80 | – | OS63GD | – | AF26-30-22-13 |
| 049A-7 | R5 | 230/115 | S 803 S-B/C 80 | – | OS63GD | – | AF30-30-22-13 |
| 061A-7 | R6 | 230/115 | S 803 S-B/C 125 | – | OS125GD | – | AF50-30-22-70 |
| 084A-7 | R6 | 230/115 | S 803 S-B/C 125 | – | OS125GD | – | AF50-30-22-70 |
| 098A-7 | R7 | 230/115 | – | 1SDA068555R1 500 V: Prospective SC current 65 kA >500 V Prospective SC current 20 kA *) 1SDA068555R1 500 V: Prospective SC current 65 kA >500 V Prospective SC current 20 kA | OS125GD | – | AF50-30-22-70 |
| 119A-7 | R7 | 230/115 | – | 1SDA068555R1 500 V: Prospective SC current 65 kA >500 V Prospective SC current 20 kA *) 1SDA054071R1 500 V: Prospective SC current 65 kA >500 V Prospective SC current 35 kA | OS160GD | – | AF75-30-22-70 |
| 142A-7 | R8 | 230/115 | – | 1SDA068555R1 500 V: Prospective SC current 65 kA >500 V Prospective SC current 20 kA *) 1SDA054071R1 500 V: Prospective SC current 65 kA >500 V Prospective SC current 35 kA | OS250D12 | – | AF95-30-22-70 |
| 174A-7 | R8 | 230/115 | – | 1SDA054141R1 500 V: Prospective SC current 65 kA >500 V Prospective SC current 35 kA | OS250D12 | – | AF145-30-22-70 |
| 210A-7 | R9 | 230/115 | – | 1SDA054365R1 500 V: Prospective SC current 65 kA >500 V Prospective SC current 35 kA | OS250D12 | – | AF145-30-22-70 |
| 271A-7 | R9 | 230/115 | – | 1SDA054420R1 500 V: Prospective SC current 65 kA >500 V Prospective SC current 35 kA | OS400D12 | – | AF185-30-22-70 |

| ACS880-04 *) | | | | |
|--------------------------------|------------|--------------------|---------------------------------------|--|
| Type designation ACS880-04- | Frame size | Aux. Contr. Volt.: | Miniature circuit breaker ABB type | T_{max} moulded case circuit breaker ABB type |
| $U_N = 400 V$ | | | | |
| 505A-3 | R10 | 230/115 | - | 1SDA054412R1 |
| 585A-3 | R10 | 230/115 | - | 1SDA069428R1 |
| 650A-3 | R10 | 230/115 | - | 1SDA069428R1 |
| 725A-3 | R11 | 230/115 | - | 1SDA062770R1 |
| 820A-3 | R11 | 230/115 | - | 1SDA062770R1 |
| 880A-3 | R11 | 230/115 | - | 1SDA062770R1 |

| ACS880-04 *) | | | | |
|--------------------------------|------------|--------------------|---------------------------------------|---|
| Type designation ACS880-04- | Frame size | Aux. Contr. Volt.: | Miniature circuit breaker ABB type | T_{max} moulded case circuit breaker ABB type |
| $U_N = 500 V$ | | | | |
| 460A-5 | R10 | 230/115 | - | 1SDA054412R1 (T5H 630 PR221DS-LS/I $I_n = 630$ 3p F F) |
| 503A-5 | R10 | 230/115 | - | 1SDA054412R1 (T5H 630 PR221DS-LS/I $I_n = 630$ 3p F F) |
| 583A-5 | R10 | 230/115 | - | 1SDA054412R1 (T5H 630 PR221DS-LS/I $I_n = 630$ 3p F F) |
| 635A-5 | R10 | 230/115 | - | 1SDA069428R1 (T6V 800 PR221DS-LS/I $I_n = 800$ 3p F F) |
| 715A-5 | R11 | 230/115 | - | 1SDA062770R1 (T7H 1000 PR231/P LS/I $I_n = 1000A$ 3p F F) |
| 820A-5 | R11 | 230/115 | - | 1SDA062770R1 (T7H 1000 PR231/P LS/I $I_n = 1000A$ 3p F F) |
| 880A-5 | R11 | 230/115 | - | 1SDA062770R1 (T7H 1000 PR231/P LS/I $I_n = 1000A$ 3p F F) |

| ACS880-04 *) | | | | |
|--------------------------------|------------|--------------------|---------------------------------------|--|
| Type designation ACS880-04- | Frame size | Aux. Contr. Volt.: | Miniature circuit breaker ABB type | T_{max} moulded case circuit breaker ABB type |
| $U_N = 690 V$ | | | | |
| 330A-7 | R10 | 230/115 | - | 1SDA054412R1 (T5H 630 PR221DS-LS/I $I_n = 630$ 3p F F) |
| 370A-7 | R10 | 230/115 | - | 1SDA054412R1 (T5H 630 PR221DS-LS/I $I_n = 630$ 3p F F) |
| 430A-7 | R10 | 230/115 | - | 1SDA054412R1 (T5H 630 PR221DS-LS/I $I_n = 630$ 3p F F) |
| 470A-7 | R11 | 230/115 | - | 1SDA054412R1 (T5H 630 PR221DS-LS/I $I_n = 630$ 3p F F) |
| 522A-7 | R11 | 230/115 | - | 1SDA069428R1 (T6V 800 PR221DS-LS/I $I_n = 800$ 3p F F) |
| 590A-7 | R11 | 230/115 | - | 1SDA069428R1 (T6V 800 PR221DS-LS/I $I_n = 800$ 3p F F) |
| 650A-7 | R11 | 230/115 | - | - |
| 721A-7 | R11 | 230/115 | - | - |

*) T_{max} moulded case circuit breakers are defined per module and the same principle may also be applied with ACS880-04XT

ACS880-04F

Circuit breakers (IEC) must not be used without fuses

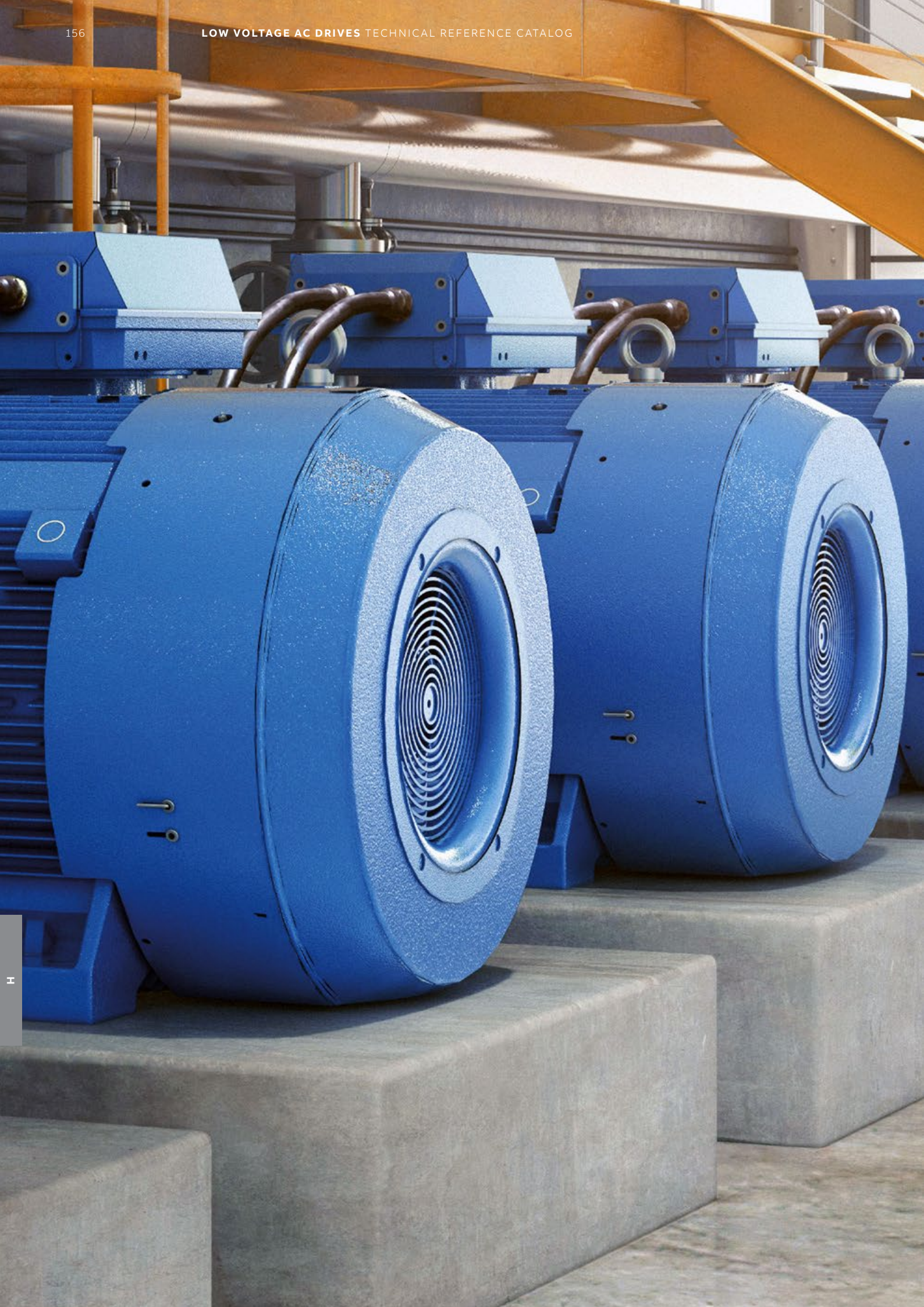

I

Motor cables

Motor cable requirements

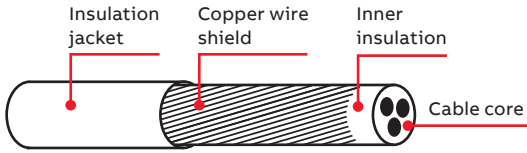

- The requirements in this section apply for CE or C-Tick compliance - Minimum requirement (CE & C-Tick)
- The motor cable must be a symmetrical, three-conductor cable with a concentric PE conductor, or a four-conductor cable with a concentric shield; however, a symmetrically constructed PE conductor is always recommended

The following image shows the minimum requirement for the motor cable shield (for example, MCMK, Draka NK Cables).

Recommendation for conductor layout

The following image compares conductor layout features in motor cables

Recommended (CE & C-Tick)

Symmetrical shielded cable: three phase conductors and a concentric or otherwise symmetrically constructed PE conductor, and a shield.

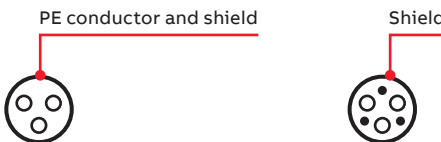

Not allowed for motor cables (CE & C-Tick)

A four-conductor system: three phase conductors and a protective conductor, without a shield.



Allowed (CE & C-Tick)

A separate PE conductor is required if the conductivity of the cable shield is <50% of the conductivity of the phase conductor.



Allowed for motor cables with phase conductor cross section up to 10 mm².

Effective motor cable shields

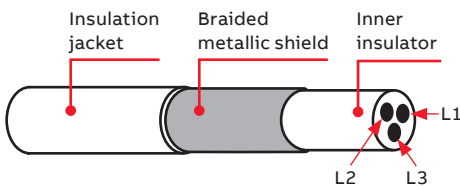

The general rule for cable shield effectiveness is: the better and tighter the cable's shield, the lower the radiated emission level. The following image shows an example of an effective construction (for example Ölflex-Servo-FD 780 CP, Lappkabel or MCCMK, NK Cables).

- Motor cable shield wires must be twisted together into a bundle (pig-tail) – the bundle length must be less than five times its width – and connected to the marked terminal (at the bottom right-hand corner of the drive).
- At the motor end, the motor cable shield must be earthed 360 degrees with an EMC cable gland, or the shield wires must be twisted together into a bundle (pigtail) not longer than five times its width and connected to the PE terminal of the motor.

Connecting the motor cables

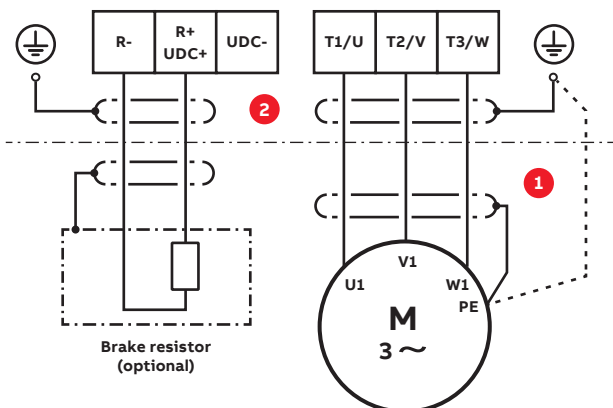

1. Separate grounding cable (motor side). Use if the conductivity of the shield is not sufficient for the protective grounding, or there is no symmetrically constructed grounding conductor in the cable.
2. 360-degree grounding of the cable shield. Required for the motor cable and brake resistor cable, recommended for the input power cable.

Motor cable lengths

ACS380, operational functionality and motor cable length

The drive is designed to operate with optimum performance with the following maximum motor cable lengths.

Note: In multimotor systems, the calculated sum of all motor cable lengths must not exceed the maximum motor cable length given in the table.

| Frame size | (m) |
|---|-----|
| Standard drive, without external options | |
| R0...R4 | 100 |

ACS380, EMC compatibility and motor cable length

To comply with the European EMC Directive (standard IEC/EN 61800-3), use the following maximum motor cable lengths at 4 kHz switching frequency.

Note: Category C1 with external EMC filter for conducted emissions only. Radiated emissions with ACS380-040x drives are not compatible when measured with a standard emission measurement setup, and should be verified on metal enclosure and machine installations case by case.

| Drive type | Frame size | Internal EMC filter | |
|-------------------------------------|------------|---------------------|-----------------------|
| | | EMC category | Max. cable length (m) |
| ACS380-040x-xxxx-1 (1-phase 230 V) | R0-R2 | C4 | – |
| ACS380-040x-xxxx-4 (3-phase 400 V) | R0-R4 | C3 | 30 ¹⁾ |
| ACS380-042x-xxxx-1/4 (230 V, 400 V) | R0-R4 | C2 | 10 |
| | | External EMC filter | |
| | | EMC category | Max. cable length (m) |
| ACS380-040x-xxxx-1 (1-phase 230 V) | R0-R1 | C1 | 10 |
| | R2 | – | – |
| ACS380-040x-xxxx-4 (3-phase 400 V) | R0-R4 | C1 | 40 ²⁾ |

¹⁾ For R2 frame, the maximum motor cable length is 20 m.

²⁾ For R0 and R4 frames, the maximum motor cable length is 30 m.

ACS480, operational functionality and motor cable length

The drive is designed to operate with optimum performance with the following maximum motor cable lengths.

Note: In multimotor systems, the calculated sum of all motor cable lengths must not exceed the maximum motor cable length given in the table.

| Frame size | (m) |
|---|-----|
| Standard drive, without external options | |
| R1...R4 | 100 |

ACS480, EMC compatibility and motor cable length

To comply with the European EMC Directive (standard IEC/EN 61800-3), use the following maximum motor cable lengths at 4 kHz switching frequency.

Note: Category C1 with external EMC filter for conducted emissions only. Radiated emissions with ACS480-040 drives are not compatible when measured with a standard emission measurement setup, and should be verified on metal enclosure and machine installations case by case.

| Drive type | Frame size | Internal EMC filter | |
|------------|------------|---------------------|-----------------------|
| | | EMC category | Max. cable length (m) |
| ACS480 | R1-R4 | C2 | 10 |
| | | External EMC filter | |
| | | EMC category | Max. cable length (m) |
| ACS480 | R1-R4 | C1 | 40 ¹⁾ |

¹⁾ For R0 and R4 frames, the maximum motor cable length is 30 m.

ACS580-01, operational functionality and motor cable length

The drive is designed to operate with optimum performance with the following maximum motor cable lengths.

Note 1: Conducted and radiated emissions of these motor cable lengths do not comply with EMC requirements.

Note 2: In multimotor systems, the calculated sum of all motor cable lengths must not exceed the maximum motor cable length given in the table.

| Frame size | Scalar control (m) | Vector control (m) |
|---|--------------------|--------------------|
| Standard drive, without external options | | |
| R1 | 150 | 150 |
| R2 ^{*)} | 200 | 200 |
| R3...R9 ^{*)} | 300 | 300 |

^{*)} For 600 V drives the maximum motor cable length is 100 m for frame R2 and 200 m for frame R3.

ACS580-01, EMC compatibility and motor cable length

To comply with the European EMC Directive (standard EN 61800-3), use the following maximum motor cable lengths at 4 kHz switching frequency. See the table below.

- Note 1:** Radiated and conducted emissions are according to category C2 with an internal EMC filter. The internal EMC filter must be connected.
- Note 2:** Categories C1 and C2 meet requirements for connecting equipment to the public low-voltage networks.
- Note 3:** Radiated and conducted emissions are according to category C3 with an internal EMC filter. The internal EMC filter must be connected.
- Note 4:** Not applicable to 600 V ratings.

| Frame size | EMC limits for Category C2 | EMC limits for Category C3 |
|------------|---|---|
| | 1) Standard drive with an internal EMC filter. (See notes 1 and 2). (m) | 1) Standard drive with an internal EMC filter. (See notes 3 and 4). (m) |
| R1...R3 | 100 | 150 |
| R4...R5 | 100 | 150 |
| R6...R9 | 150 | 150 |

ACS580-04, operational functionality and motor cable length

Note: Motor cables longer than 100 m are allowed, but then the EMC Directive requirements of Category C3 may not be fulfilled.

| Frame size | Scalar control (m) | Vector control (m) |
|------------|--|--------------------|
| | Standard drive, without external options | |
| R10...R11 | 300 | 300 |

ACS580-07, operational functionality and motor cable length

Note: With motor cables longer than 100 m, the EMC Directive requirements may not be fulfilled.

| Frame size | (m) |
|--|-----|
| Standard drive, without external options | |
| R6...R11 | 300 |

ACS880-01, ACS880-04, ACS880-04XT, ACS880-04FXT, ACS880-07, ACS880-11, ACS880-14, ACS880-17, ACS880-31, ACS880-34, ACS880-37, operational functionality and motor cable length

The following motor cable lengths should not be exceeded due to probable loss of motor control. Maximum motor cable lengths depend on control mode (scalar or DTC).

- ¹⁾ With DTC control, it is **recommended to select a drive with one size higher rating (IN)** taking into account the voltage drop when using motor cables >150 m (frames R1-R3), >300 m (frames R4-R9) or >500 m (frames R10-R11).
- ²⁾ With Scalar control, select the drive taking into account the voltage drop and **choose a drive with one size higher rating (IN)** when using motor cables >150 m (frames R1-R3), >300 m (frames R4-R9) or >500 m (frames R10-R11).

Note: Longer cables cause a voltage drop, which limits the available motor power. The decrease in the voltage depends on the motor cable length and characteristics. Contact ABB for more information. Note that a sine filter (optional) at the drive output also causes a voltage drop.

| Frame size | DTC control (m) | | Scalar control (m) | |
|------------|-----------------|-----------------------|--------------------|-----------------------|
| | HW manual | Special ¹⁾ | HW manual | Special ²⁾ |
| R1 | 150 | 300 | 150 | 300 |
| R2 | 150 | 500 | 150 | 300 |
| R3 | 150 | 500 | 150 | 500 |
| R4 | 300 | 700 | 300 | 700 |
| R5 | 300 | 700 | 300 | 700 |
| R6 | 300 | 700 | 300 | 700 |
| R7 | 300 | 700 | 300 | 700 |
| R8 | 300 | 700 | 300 | 700 |
| R9 | 300 | 700 | 300 | 700 |
| R10 | 500 | 700 | 500 | 700 |
| R11 | 500 | 700 | 500 | 700 |

ACS880-01, ACS880-04, ACS880-04XT, ACS880-07, EMC compatibility and motor cable length

In the ACS880-01 series, the usage of **300 m motor cable** length is possible while compliance with EN 61800-3:2004 **Category C3** is fulfilled.

In the ACS880-04 series, the usage of **300 m motor cable** length is possible while compliance with EN 61800-3:2004 **Category C3** is fulfilled with C2 category filters.

However, there are certain restrictions and also requirements that must be met to enable this.

Note: There is no extensive type test documentation available to prove EMC emission level results.

| Frame size | HW manual | Special | Special requirements |
|------------|-----------|---------|---|
| R1...R3 | 150 | 300 | EMC filter +E200 or +E202 |
| R4...R5 | 150 | 300 | EMC filter +E200 or +E202, and output Sine filter |
| R6...R9 | 150 | 300 | EMC filter +E200 or +E202 |
| R10...R11 | 150 | N/A | EMC filter +E200 or +E202 |
| R10...R11 | N/A | 300 | EMC filter +E202/ARFI-10 + E208 |

du/dt filters

What are du/dt filters?

du/dt filtering suppresses inverter output voltage spikes and rapid voltage changes that stress motor insulation. Additionally, du/dt filters reduce capacitive leakage currents and high frequency emissions from the motor cable, as well as high frequency losses and bearing currents in the motor.

Optional du/dt filters protect the motor insulation system by reducing the voltage rise speed at the motor terminals. The filter also protects the motor bearings by reducing the bearing currents.



—
NOCH0016-62
Available for ACS380,
ACS580 and ACS880.

Why do we need du/dt filters?

High-frequency voltage components cause:

- Voltage spikes and rapid voltage changes
- Additional stress on the motor
- Motor cable insulation

The du/dt filters:

- Minimize voltage reflections, bearing currents and harmonic distortion
- Protect the motor insulation system by reducing the voltage rise speed at the motor terminals

Graphs illustrating the effect of the du/dt filter

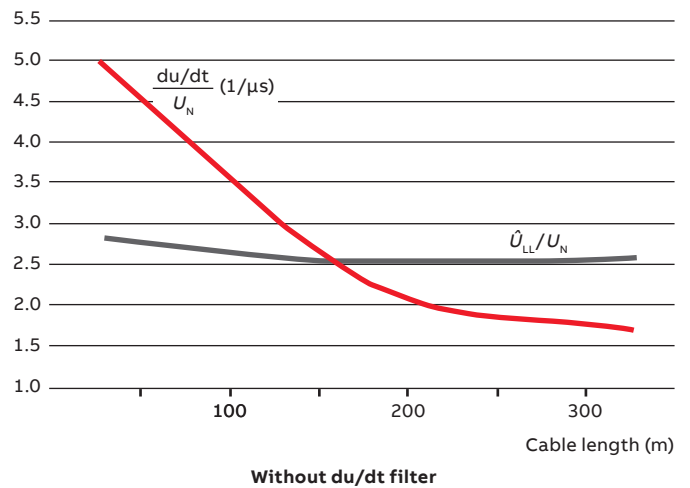
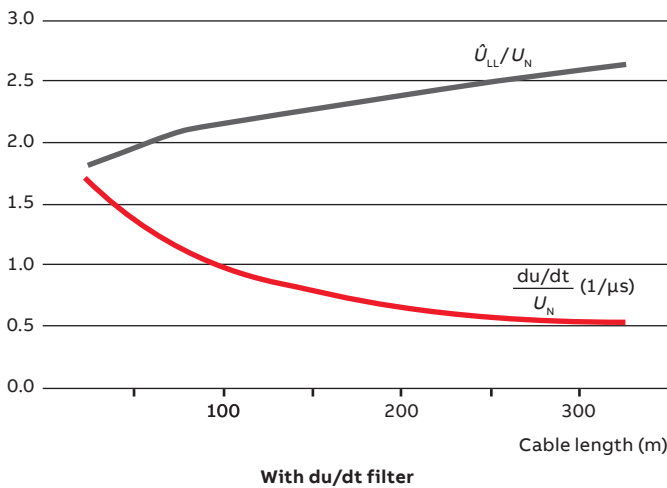

The graphs show the peak line-to-line voltage (\hat{U}_{LL}) and voltage change (du/dt) at the motor terminals as a function of the motor cable length. \hat{U}_{LL} and du/dt are scaled to the nominal line-to-line voltage (U_N). To calculate the actual peak voltage value in volts and du/dt value in volts per microsecond, multiply the values of the graph by the supply voltage (U_N).

The values in the first graph are measured with an ABB du/dt filter, while the second graph is without any output filtering. The values in the second graph are only representative. The actual unfiltered du/dt values depend on the drive type, and are usually in the range of 1 to 5 kV/microsecond. For drives with an IGBT supply unit or resistor braking, the \hat{U}_{LL} and du/dt values are approximately 20 percent higher. The voltage rise time can be calculated as follows: $t = 0.8 \cdot \hat{U}_{LL}/(du/dt)$.

External du/dt filter for ACS580

| Type designation | du/dt filter type | | | | | | | | | | | | | | | | | | |
|--|--------------------|-------------|-------------|---------------------------|-------------|-------------|-------------|-------------------|-------------|-------------|-------------|-------------------|-------------|-------------|-------------|-------------|--------------|---------|---------|
| | Unprotected (IP00) | | | | | | | Protected to IP22 | | | | Protected to IP54 | | | | | | | |
| | NOCH0016-60 | NOCH0030-60 | NOCH0070-60 | NOCH0120-60 ^{*)} | FOCH0260-70 | FOCH0320-50 | FOCH0610-70 | FOCH0875-70 | NOCH0016-62 | NOCH0030-62 | NOCH0070-62 | NOCH0120-62 | NOCH0016-65 | NOCH0030-65 | NOCH0070-65 | NOCH0120-65 | BOCH-0880A-7 | COF -01 | COF -02 |
| 3-phase, $U_N = 380...480$ V | | | | | | | | | | | | | | | | | | | |
| ACS580-01-02A7-4 | • | | | | | | | • | | | | • | | | | | | | |
| ACS580-01-03A4-4 | • | | | | | | | • | | | | • | | | | | | | |
| ACS580-01-04A1-4 | • | | | | | | | • | | | | • | | | | | | | |
| ACS580-01-05A7-4 | • | | | | | | | • | | | | • | | | | | | | |
| ACS580-01-07A3-4 | • | | | | | | | • | | | | • | | | | | | | |
| ACS580-01-09A5-4 | • | | | | | | | • | | | | • | | | | | | | |
| ACS580-01-12A7-4 | • | | | | | | | • | | | | • | | | | | | | |
| ACS580-01-018A-4 | | • | | | | | | | • | | | | • | | | | | | |
| ACS580-01-026A-4 | | • | | | | | | | • | | | | • | | | | | | |
| ACS580-01-033A-4 | | | • | | | | | | | • | | | | • | | | | | |
| ACS580-01-039A-4 | | | • | | | | | | | • | | | | • | | | | | |
| ACS580-01-046A-4 | | | • | | | | | | | • | | | | • | | | | | |
| ACS580-01-062A-4 | | | • | | | | | | | • | | | | • | | | | | |
| ACS580-01-073A-4 | | | | • | | | | | | | • | | | | • | | | | |
| ACS580-01-088A-4 | | | | • | | | | | | | • | | | | • | | | | |
| ACS580-01-106A-4 | | | | • | | | | | | | • | | | | • | | | | |
| ACS580-01-145A-4 | | | | | • | | | | | | | | | | | | | | |
| ACS580-01-169A-4 | | | | | • | | | | | | | | | | | | | | |
| ACS580-01-206A-4 | | | | | • | | | | | | | | | | | | | | |
| ACS580-01-246A-4 | | | | | • | | | | | | | | | | | | | | |
| ACS580-01-293A-4 | | | | | • | | | | | | | | | | | | | | |
| ACS580-01-363A-4 | | | | | | • | | | | | | | | | | | | | |
| ACS580-01-430A-4 | | | | | | • | | | | | | | | | | | | | |
| $U_N = 380-480$ V (380-415 V, 440-480 V) | | | | | | | | | | | | | | | | | | | |
| ACS580-04-505A-4 | | | | | | | • | | | | | | | | | | | | |
| ACS580-04-585A-4 | | | | | | | • | | | | | | | | | | | | |
| ACS580-04-650A-4 | | | | | | | • | | | | | | | | | | | | |
| ACS580-04-725A-4 | | | | | | | | • | | | | | | | | | | | |
| ACS580-04-820A-4 | | | | | | | | • | | | | | | | | | | | |
| ACS580-04-880A-4 | | | | | | | | • | | | | | | | | | | | |
| $U_N = 400$ V (380-415 V, 440-480 V) | | | | | | | | | | | | | | | | | | | |
| ACS580-07-0145A-4 | | | | | | | | | | | | | | | | | | • | |
| ACS580-07-0169A-4 | | | | | | | | | | | | | | | | | | • | |
| ACS580-07-0206A-4 | | | | | | | | | | | | | | | | | | • | |
| ACS580-07-0246A-4 | | | | | | | | | | | | | | | | | | | • |
| ACS580-07-0293A-4 | | | | | | | | | | | | | | | | | | | • |
| ACS580-07-0363A-4 | | | | | | | | | | | | | | | | | | | • |
| ACS580-07-0430A-4 | | | | | | | | | | | | | | | | | | | • |
| ACS580-07-0505A-4 | | | | | | | | | | | | | | | | | • | | |
| ACS580-07-0585A-4 | | | | | | | | | | | | | | | | | • | | |
| ACS580-07-0650A-4 | | | | | | | | | | | | | | | | | • | | |
| ACS580-07-0725A-4 | | | | | | | | | | | | | | | | | • | | |
| ACS580-07-0820A-4 | | | | | | | | | | | | | | | | | • | | |
| ACS580-07-0880A-4 | | | | | | | | | | | | | | | | | • | | |

^{*)} 3 filters included, dimensions apply to one filter

| External du/dt filter for ACS880-01, ACS880-11 and ACS880-31 | | | | | | | | | | | | | | | | | | |
|--|--------|--------|------------------|-------------|-------------|----------------|-------------------|-------------|-------------|-------------|-------------------|-------------|-------------|-------------|-------------|-------------|-------------|-------------|
| du/dt filter type | | | | | | | | | | | | | | | | | | |
| *) 3 filters included, dimensions apply to one filter. | | | | | | | | | | | | | | | | | | |
| | | | Unprotected IP00 | | | | Protected to IP22 | | | | Protected to IP54 | | | | | | | |
| 400 V | 500 V | 690 V | NOCH0016-60 | NOCH0030-60 | NOCH0070-60 | NOCH0120-60 *) | FOCH0260-70 | FOCH0320-50 | NOCH0016-62 | NOCH0030-62 | NOCH0070-62 | NOCH0120-62 | FOCH0260-72 | FOCH0320-52 | NOCH0016-65 | NOCH0030-65 | NOCH0070-65 | NOCH0120-65 |
| 02A4-3 | 02A1-5 | | • | | | | | | • | | | | | | • | | | |
| 03A3-3 | 03A0-5 | | • | | | | | | • | | | | | | • | | | |
| | 03A4-5 | | • | | | | | | • | | | | | | • | | | |
| 04A0-3 | 04A8-5 | 07A3-7 | • | | | | | | • | | | | | | • | | | |
| 05A6-3 | 05A2-5 | 07A4-7 | • | | | | | | • | | | | | | • | | | |
| 07A2-3 | 07A6-5 | 09A8-7 | • | | | | | | • | | | | | | • | | | |
| 09A4-3 | | 09A9-7 | • | | | | | | • | | | | | | • | | | |
| 12A6-3 | 11A0-5 | 14A2-7 | • | | | | | | • | | | | | | • | | | |
| | | 14A3-7 | • | | | | | | • | | | | | | • | | | |
| | 014A-5 | 018A-7 | • | | | | | | • | | | | | | • | | | |
| 017A-3 | | 019A-7 | • | | | | | | • | | | | | | • | | | |
| | 021A-5 | 022A-7 | • | | | | | | • | | | | | | • | | | |
| | | 023A-7 | • | | | | | | • | | | | | | • | | | |
| 025A-3 | | 026A-7 | • | | | | | | • | | | | | | • | | | |
| | | 027A-7 | • | | | | | | • | | | | | | • | | | |
| | 027A-5 | | | • | | | | | • | | | | | | • | | | |
| 032A-3 | 034A-5 | 035A-7 | • | | | | | | • | | | | | | • | | | |
| 038A-3 | 040A-5 | 042A-7 | • | | | | | | • | | | | | | • | | | |
| 045A-3 | 052A-5 | 049A-7 | • | | | | | | • | | | | | | • | | | |
| 061A-3 | | | • | | | | | | • | | | | | | • | | | |
| | 065A-5 | 061A-7 | | • | | | | | • | | | | | | • | | | |
| 072A-3 | 077A-5 | | | • | | | | | • | | | | | | • | | | |
| 087A-3 | | 084A-7 | | • | | | | | • | | | | | | • | | | |
| 105A-3 | 096A-5 | | | • | | | | | • | | | | | | • | | | |
| | 124A-5 | 119A-7 | | | | | • | | | | | | • | | | | | |
| 145A-3 | 156A-5 | 142A-7 | | | | | • | | | | | | • | | | | | |
| 169A-3 | 180A-5 | 174A-7 | | | | | • | | | | | | • | | | | | |
| 206A-3 | 240A-5 | 210A-7 | | | | | • | | | | | | • | | | | | |
| 246A-3 | 260A-5 | 271A-7 | | | | | • | | | | | | • | | | | | |
| 293A-3 | | | | | | | • | | | | | | • | | | | | |
| 363A-3 | 361A-5 | | | | | | | • | | | | | | • | | | | |
| 430A-3 | 414A-5 | | | | | | | • | | | | | | • | | | | |

| External du/dt filter for ACS880 -04/04F, ACS880-14/34 R11 and ACS880-04XT/04FXT *) | | | | | | | | | |
|---|--------|--------|-------------|-------------|-------------|-------------|-------------|--|--|
| | | | FOCH0260-5X | FOCH0320-5X | FOCH0610-7X | FOCH0875-7X | FOCH0260-7X | | |
| 400 V | 500 V | 690 V | | | | | | | |
| | 240A-5 | 142A-7 | | | | | • | | |
| | 260A-5 | 174A-7 | | | | | • | | |
| | | 210A-7 | | | | | • | | |
| | | 271A-7 | | | | | • | | |
| 246A-3 | | | • | | | | | | |
| 293A-3 | | | • | | | | | | |
| 363A-3 | 302A-5 | | | • | | | | | |
| 442A-3 | 361A-5 | | | • | | | | | |
| | 414A-5 | | | • | | | | | |
| 505A-3 | 460A-5 | 330A-7 | | | • | | | | |
| 585A-3 | 503A-5 | 370A-7 | | | • | | | | |
| 650A-3 | | 430A-7 | | | • | | | | |
| | | 330A-7 | | | • | | | | |
| | | 370A-7 | | | • | | | | |
| | 459A-5 | | | | • | | | | |
| | 460A-5 | 425A-7 | | | • | | | | |
| | | 430A-7 | | | • | | | | |
| 504A-3 | 502A-5 | | | | • | | | | |
| 505A-3 | 503A-5 | 470A-7 | | | • | | | | |
| 584A-3 | 582A-5 | | | | • | | | | |
| 585A-3 | 583A-5 | 522A-7 | | | • | | | | |
| 649A-3 | 634A-5 | | | | • | | | | |
| 650A-3 | 635A-5 | 590A-7 | | | • | | | | |
| 725A-3 | 715A-5 | 650A-7 | | | | • | | | |
| 820A-3 | 820A-5 | 721A-7 | | | | • | | | |
| 880A-3 | 880A-5 | | | | | • | | | |

*) For ACS880-04XT/FXT one filter per drive module is needed.

Applicability

Separate du/dt filters are available for ACS880-01/04/04F/04XT/04FXT/11/31 and -14/34 R11. Unprotected IP00 filters must be placed into an enclosure that provides an adequate degree of protection.

Dimensions and weights of the du/dt filters

| du/dt filter | Height (mm) | Width (mm) | Depth (mm) | Weight (kg) |
|----------------|-------------|------------|------------|-------------|
| NOCH0016-60 | 195 | 140 | 115 | 2.4 |
| NOCH0016-62/65 | 323 | 199 | 154 | 6 |
| NOCH0030-60 | 215 | 165 | 130 | 4.7 |
| NOCH0030-62/65 | 348 | 249 | 172 | 9 |
| NOCH0070-60 | 261 | 180 | 150 | 9.5 |
| NOCH0070-62/65 | 433 | 279 | 202 | 15.5 |
| NOCH0120-60 | 200 | 154 | 106 | 7 |
| NOCH0120-62/65 | 765 | 308 | 256 | 45 |
| FOCH0260-70 | 382 | 340 | 254 | 47 |
| FOCH0320-50 | 662 | 319 | 293 | 65 |
| FOCH0610-70 | 662 | 319 | 293 | 65 |
| FOCH0875-70 | 662 | 319 | 293 | 65 |
| BOCH-0880A-7 | 400 | 248 | 456 | 18 |
| COF-01 | 570 | 296 | 360 | 23 |
| COF-02 | 570 | 360 | 301 | 23 |



Sine filters

What are sine filters?

Sine filters are low-pass filters that suppress the high frequency components of the drive output.

A sine filter consists of single- or three-phase reactors and delta- or star-connected capacitors. The sine filter provides true sinusoidal voltage waveform at the drive

output by suppressing the high frequency voltage components of the drive output.

Suppression of the high frequency voltage components is needed when extra-long motor cables are used, there is a step-up transformer between the drive and a motor, or when a drive is installed with an old direct-on-line motor.

Why do we need sine filters?

High frequency voltage components cause:

- Stress on the motor insulation
- Output transformer saturation (if any)

Sine filters:

- Minimize voltage reflections, bearing currents and harmonic distortion. Thus, you can use longer motor cables or install a drive with an old on-line motor.
- Reduce the motor noise level in most cases
- Allow you to use an output transformer. With the transformer, you can use a low voltage drive with a medium voltage motor, for example.

Note: ACS880 drives can be used with sine filter in either DTC or scalar control modes. In ACS580 drives you must use the scalar motor control mode of the drive with a sine filter instead of the vector control mode. This limits the motor control accuracy somewhat.

This overview diagram shows a drive system with a sine filter.

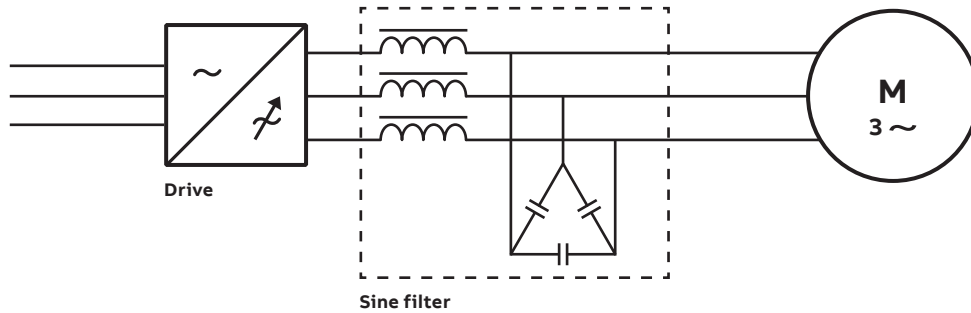

| ACS580-01, sine filters | | | |
|--|------------------|-------------------|------------------------|
| Type designation | IP00 | Type code | $I_{cont. max}$ (A) |
| | Sine filter type | Housing case IP21 | |
| 3-phase, $U_N = 380...480$ V. The power ratings are valid at nominal voltage 400 V (0.75 to 250 kW). | | | |
| ACS580-01-02A7-4 | B84143V0004R229 | B84143Q0002R229 | 2.3 |
| ACS580-01-03A4-4 | B84143V0004R229 | B84143Q0002R229 | 3.1 |
| ACS580-01-04A1-4 | B84143V0004R229 | B84143Q0002R229 | 3.8 |
| ACS580-01-05A7-4 | B84143V0006R229 | B84143Q0002R229 | 5.3 |
| ACS580-01-07A3-4 | B84143V0011R229 | B84143Q0004R229 | 6.9 |
| ACS580-01-09A5-4 | B84143V0011R229 | B84143Q0004R229 | 9.2 |
| ACS580-01-12A7-4 | B84143V0016R229 | B84143Q0006R229 | 12.1 |
| ACS580-01-018A-4 | B84143V0016R229 | B84143Q0006R229 | 16 |
| ACS580-01-026A-4 | B84143V0025R229 | B84143Q0008R229 | 24 |
| ACS580-01-033A-4 | B84143V0033R229 | B84143Q0008R229 | 31 |
| ACS580-01-039A-4 | B84143V0050R229 | B84143Q0010R229 | 37 |
| ACS580-01-046A-4 | B84143V0050R229 | B84143Q0010R229 | 43 |
| ACS580-01-062A-4 | B84143V0066R229 | B84143Q0010R229 | 58 |
| ACS580-01-073A-4 | B84143V0066R229 | B84143Q0010R229 | 64 |
| ACS580-01-088A-4 | B84143V0095R229 | B84143Q0012R229 | 77 |
| ACS580-01-106A-4 | B84143V0095R229 | B84143Q0012R229 | 91 |
| ACS580-01-145A-4 | B84143V0162S229 | B84143Q0014R229 | 126 |
| ACS580-01-169A-4 | B84143V0162S229 | B84143Q0014R229 | 153 |
| ACS580-01-206A-4 | B84143V0230S229 | B84143Q0016R229 | 187 |
| ACS580-01-246A-4 | B84143V0230S229 | B84143Q0016R229 | 209 |
| ACS580-01-293A-4 | B84143V0390S229 | B84143Q0018R229 | 249 |
| ACS580-01-363A-4 | B84143V0390S229 | B84143Q0018R229 | 297 |
| ACS580-01-430A-4 | B84143V0390S229 | B84143Q0018R229 | 352 |

If a sinus filter IP21 is needed please order both type codes for Housing case IP21 and Sine filter IP00. Example: if a IP21 sine filter is needed for an ACS580-01-02A7-4 it is necessary to order both B84143V0004R229 and B84143Q0002R229.

| ACS880-04, ACS880-04XT, sine filters | |
|--------------------------------------|------------------|
| Type designation | Sine filter type |
| $U_N = 400$ V | |
| ACS880-04-505A-3 | NSIN900-6 |
| ACS880-04-585A-3***) | NSIN900-6 |
| ACS880-04-650A-3***) | NSIN900-6 |
| ACS880-04-725A-3***) | NSIN900-6 |
| ACS880-04-820A-3 | NSIN900-6 |
| ACS880-04-880A-3***) | NSIN900-6 |
| $U_N = 500$ V | |
| ACS880-04-460A-5 | NSIN0485-6 |
| ACS880-04-503A-5 | NSIN900-6 |
| ACS880-04-583A-5***) | NSIN900-6 |
| ACS880-04-635A-5***) | NSIN900-6 |
| ACS880-04-715A-5***) | NSIN900-6 |
| ACS880-04-820A-5 | NSIN900-6 |
| ACS880-04-880A-5***) | NSIN900-6 |
| $U_N = 690$ V | |
| ACS880-04-330A-7 | NSIN485-6 |
| ACS880-04-370A-7 | NSIN485-6 |
| ACS880-04-430A-7***) | NSIN485-6 |
| ACS880-04-470A-7 | NSIN900-6 |
| ACS880-04-425A-7 | NSIN0485-6 |
| ACS880-04-522A-7***) | NSIN0485-6 |
| ACS880-04-590A-7***) | NSIN0485-6 |
| ACS880-04-650A-7 | NSIN900-6 |
| ACS880-04-721A-7***) | NSIN900-6 |

***) Can also be applied to ACS880-04XT and -04FXT, one filter for each drive module.

| ACS880-01, sine filters | | | | | | | | |
|--|--------------------|------------------------|-------------------------|------------------|--------|-------|-------------------|--|
| Type designation | Sine filter type | $I_{cont. max}$ (A) | $P_{cont. max}$ (kW) | Heat dissipation | | | Noise (dB (A)) | |
| | | | | Drive | Filter | Total | | |
| $U_N = 400$ V (range 380 to 415 V). The power ratings are valid at nominal voltage 400 V (0.55 to 250 kW). | | | | | | | | |
| ACS880-01-02A4-3 | B84143V0004R229*) | 2.3 | 1.7 | 30 | 60 | 90 | 72 | |
| ACS880-01-03A3-3 | B84143V0004R229*) | 3.1 | 2.3 | 40 | 60 | 100 | 72 | |
| ACS880-01-04A0-3 | B84143V0004R229*) | 3.8 | 2.9 | 52 | 60 | 112 | 72 | |
| ACS880-01-05A6-3 | B84143V0006R229*) | 5.3 | 4.0 | 73 | 100 | 173 | 72 | |
| ACS880-01-07A2-3 | B84143V0011R229*) | 7.2 | 5.4 | 94 | 90 | 184 | 72 | |
| ACS880-01-09A4-3 | B84143V0011R229*) | 9.2 | 6.9 | 122 | 90 | 212 | 72 | |
| ACS880-01-12A6-3 | B84143V0016R229*) | 12.1 | 9.1 | 172 | 80 | 252 | 72 | |
| ACS880-01-017A-3 | B84143V0025R229*) | 16 | 12.1 | 232 | 140 | 372 | 75 | |
| ACS880-01-025A-3 | B84143V0025R229*) | 24 | 17.7 | 337 | 140 | 477 | 75 | |
| ACS880-01-032A-3 | B84143V0033R229*) | 31 | 23.4 | 457 | 160 | 617 | 75 | |
| ACS880-01-038A-3 | B84143V0050R229*) | 37 | 27.5 | 562 | 220 | 782 | 78 | |
| ACS880-01-045A-3 | B84143V0050R229*) | 43 | 32.4 | 667 | 220 | 887 | 78 | |
| ACS880-01-061A-3 | B84143V0066R229*) | 58 | 43.7 | 907 | 250 | 1157 | 78 | |
| ACS880-01-072A-3 | B84143V0075R229*) | 64 | 48.2 | 1117 | 310 | 1427 | 79 | |
| ACS880-01-087A-3 | B84143V0095R229*) | 77 | 58.0 | 1120 | 400 | 1520 | 79 | |
| ACS880-01-105A-3 | B84143V0130R230**) | 91 | 68.6 | 1295 | 600 | 1895 | 80 | |
| ACS880-01-145A-3 | B84143V0162S229**) | 126 | 94.6 | 1440 | 550 | 1990 | 80 | |
| ACS880-01-169A-3 | B84143V0162S229**) | 153 | 115.0 | 1940 | 550 | 2490 | 80 | |
| ACS880-01-206A-3 | B84143V0230S229**) | 187 | 140.6 | 2310 | 900 | 3210 | 80 | |
| ACS880-01-246A-3 | B84143V0230S229**) | 209 | 157.6 | 3300 | 900 | 4200 | 80 | |
| ACS880-01-293A-3 | B84143V0390S229**) | 249 | 187.8 | 3900 | 1570 | 5470 | 80 | |
| ACS880-01-363A-3 | B84143V0390S229**) | 297 | 223.6 | 4800 | 1570 | 6370 | 80 | |
| ACS880-01-430A-3 | B84143V0390S229**) | 352 | 265.2 | 6000 | 1570 | 7570 | 80 | |

*) Minimum switching frequency 3.0 kHz

**) Minimum switching frequency 2.4 kHz

ACS880-01, sine filters

| Type designation | Sine filter type | $I_{\text{cont. max}}$ (A) | $P_{\text{cont. max}}$ (kW) | Heat dissipation | | | Noise (dB (A)) |
|--|--------------------------------|-------------------------------|--------------------------------|------------------|-------------------|-------|-------------------|
| | | | | Drive | Filter | Total | |
| $U_N = 400 - 500 \text{ V}$ (range 380 to 500 V). The power ratings are valid at nominal voltage 500 V (0.55 to 250 kW). | | | | | | | |
| ACS880-01-02A1-5 | B84143V0004R229 ^{*)} | 1.9 | 1.4 | 30 | 60 | 90 | 72 |
| ACS880-01-03A0-5 | B84143V0004R229 ^{*)} | 2.8 | 2.1 | 40 | 60 | 100 | 72 |
| ACS880-01-03A4-5 | B84143V0004R229 ^{*)} | 3.1 | 2.3 | 52 | 60 | 112 | 72 |
| ACS880-01-04A8-5 | B84143V0006R229 ^{*)} | 4.4 | 3.3 | 73 | 100 | 173 | 72 |
| ACS880-01-05A2-5 | B84143V0006R229 ^{*)} | 4.8 | 3.6 | 94 | 100 | 194 | 72 |
| ACS880-01-07A6-5 | B84143V0011R229 ^{*)} | 7.0 | 5.3 | 122 | 90 | 212 | 72 |
| ACS880-01-11A0-5 | B84143V0011R229 ^{*)} | 10.2 | 7.7 | 172 | 90 | 262 | 72 |
| ACS880-01-014A-5 | B84143V0016R229 ^{*)} | 13 | 9.8 | 232 | 80 | 312 | 70 |
| ACS880-01-021A-5 | B84143V0025R229 ^{*)} | 20 | 14.7 | 337 | 140 | 477 | 75 |
| ACS880-01-027A-5 | B84143V0033R229 ^{*)} | 25 | 18.8 | 457 | 160 | 617 | 75 |
| ACS880-01-034A-5 | B84143V0050R229 ^{*)} | 32 | 23.7 | 562 | 220 | 782 | 78 |
| ACS880-01-040A-5 | B84143V0050R229 ^{*)} | 35 | 26.0 | 667 | 220 | 887 | 78 |
| ACS880-01-052A-5 | B84143V0066R229 ^{*)} | 44 | 33.2 | 907 | 250 | 1157 | 78 |
| ACS880-01-065A-5 | B84143V0066R229 ^{*)} | 52 | 39.2 | 1117 | 250 | 1367 | 78 |
| ACS880-01-077A-5 | B84143V0075R229 ^{*)} | 61 | 46.0 | 1120 | 310 | 1430 | 78 |
| ACS880-01-096A-5 | B84143V0130S230 ^{**)} | 80 | 60.6 | 1295 | ^{*)} 630 | 1925 | 80 |
| ACS880-01-124A-5 | B84143V0130S230 ^{**)} | 104 | 78.7 | 1440 | 630 | 2070 | 80 |
| ACS880-01-156A-5 | B84143V0162S229 ^{**)} | 140 | 105.8 | 1940 | 550 | 2490 | 80 |
| ACS880-01-180A-5 | B84143V0162S229 ^{**)} | 161 | 121.3 | 2310 | 550 | 2860 | 80 |
| ACS880-01-240A-5 | B84143V0230S229 ^{**)} | 205 | 154.3 | 3300 | 900 | 4200 | 80 |
| ACS880-01-260A-5 | B84143V0230S229 ^{**)} | 221 | 166.7 | 3900 | 900 | 4800 | 80 |
| ACS880-01-361A-5 | B84143V0390S229 ^{**)} | 289 | 217.9 | 4800 | 1570 | 6370 | 80 |
| ACS880-01-414A-5 | B84143V0390S229 ^{**)} | 332 | 250.1 | 6000 | 1570 | 7570 | 80 |

ACS880-01, sine filters

| Type designation | Sine filter type | $I_{\text{cont. max}}$ (A) | $P_{\text{cont. max}}$ (kW) | Heat dissipation | | | Noise (dB (A)) |
|---|--------------------------------|-------------------------------|--------------------------------|------------------|--------|-------|-------------------|
| | | | | Drive | Filter | Total | |
| $U_N = 690 \text{ V}$ (range 525 to 690 V). The power ratings are valid at nominal voltage 690 V (4 to 250 kW). | | | | | | | |
| ACS880-01-07A4-7 | B84143V0010R230 ^{*)} | 7.3 | 5.5 | 114 | 90 | 204 | 72 |
| ACS880-01-09A9-7 | B84143V0010R230 ^{*)} | 9.3 | 7.0 | 143 | 90 | 233 | 72 |
| ACS880-01-14A3-7 | B84143V0018R230 ^{*)} | 13.5 | 10.2 | 207 | 130 | 337 | 72 |
| ACS880-01-019A-7 | B84143V0018R230 ^{*)} | 17.1 | 12.9 | 274 | 130 | 404 | 72 |
| ACS880-01-023A-7 | B84143V0026R230 ^{*)} | 21 | 15.7 | 329 | 160 | 489 | 72 |
| ACS880-01-027A-7 | B84143V0026R230 ^{*)} | 25 | 18.6 | 405 | 160 | 565 | 72 |
| ACS880-01-07A3-7 | B84143V0010R230 ^{*)} | 7.3 | 5.5 | 217 | 90 | 307 | 72 |
| ACS880-01-09A8-7 | B84143V0010R230 ^{*)} | 9.3 | 7.0 | 284 | 90 | 374 | 72 |
| ACS880-01-14A2-7 | B84143V0018R230 ^{*)} | 13.5 | 10.2 | 399 | 130 | 529 | 72 |
| ACS880-01-018A-7 | B84143V0018R230 ^{*)} | 17.1 | 12.9 | 490 | 130 | 620 | 72 |
| ACS880-01-022A-7 | B84143V0026R230 ^{*)} | 21 | 15.7 | 578 | 160 | 738 | 72 |
| ACS880-01-026A-7 | B84143V0026R230 ^{*)} | 25 | 18.6 | 660 | 160 | 820 | 72 |
| ACS880-01-035A-7 | B84143V0040R230 ^{*)} | 33 | 25.1 | 864 | 250 | 1114 | 75 |
| ACS880-01-042A-7 | B84143V0040R230 ^{*)} | 40 | 30.1 | 998 | 250 | 1248 | 75 |
| ACS880-01-049A-7 | B84143V0056R230 ^{**)} | 48 | 36.2 | 1120 | 290 | 1410 | 78 |
| ACS880-01-061A-7 | B84143V0056R230 ^{**)} | 56 | 42.5 | 1295 | 290 | 1585 | 78 |
| ACS880-01-084A-7 | B84143V0092R230 ^{**)} | 78 | 58.6 | 1440 | 610 | 2050 | 79 |
| ACS880-01-098A-7 | B84143V0092R230 ^{**)} | 92 | 69.3 | 1940 | 610 | 2550 | 79 |
| ACS880-01-119A-7 | B84143V0130S230 ^{**)} | 112 | 84.2 | 2310 | 630 | 2940 | 80 |
| ACS880-01-142A-7 | B84143V0130S230 ^{**)} | 112 | 84.7 | 3300 | 630 | 3930 | 80 |
| ACS880-01-174A-7 | B84143V0207S230 ^{**)} | 138 | 103.7 | 3900 | 930 | 4830 | 80 |
| ACS880-01-210A-7 | B84143V0207S230 ^{**)} | 161 | 121.3 | 4200 | 930 | 5130 | 80 |
| ACS880-01-271A-7 | B84143V0207S230 ^{**)} | 208 | 156.4 | 4800 | 930 | 5730 | 80 |

Definitions

| | |
|------------------------|--|
| $P_{\text{cont. max}}$ | Maximum continuous output power of the drive |
| $I_{\text{cont. max}}$ | Maximum continuous output current of the drive |
| Noise | Noise level of the sine filters |

ACS880-11 and ACS880-31 wall-mounted regenerative and ultra-low harmonic drives, sine filters

| I_N (A) | $P_N^{1)}$ (kW) | Noise level ²⁾ (dB) | Heat dissipation ²⁾ (W) | Drive type | Filter type | Degree of protection | Filter width | | Filter depth | | Filter height | | Filter weight | | Frame size |
|---|--------------------|-----------------------------------|---------------------------------------|---------------------|-----------------|----------------------|--------------|--------------|--------------|--------------|---------------|--------------|---------------|--------------|------------|
| | | | | | | | IP00 (mm) | IP21 (mm) | IP00 (mm) | IP21 (mm) | IP00 (mm) | IP21 (mm) | IP00 (kg) | IP21 (kg) | |
| $U_N = 400$ V (range 380 to 415 V). The power ratings are valid at nominal voltage 400 V. | | | | | | | | | | | | | | | |
| 9.2 | 4 | 72 | 90 | ACS880-11/31-09A4-3 | B84143V0011R229 | IP00/IP21 | 235 | 384 | 110 | 152 | 200 | 246 | 5.2 | 14.4 | R3 |
| 12.1 | 5.5 | 72 | 80 | ACS880-11/31-12A6-3 | B84143V0016R229 | IP00/IP21 | 275 | 420 | 122 | 200 | 235 | 290 | 7.9 | 24.4 | R3 |
| 16 | 7.5 | 75 | 140 | ACS880-11/31-017A-3 | B84143V0025R229 | IP00/IP21 | 355 | 500 | 120 | 200 | 285 | 360 | 12.1 | 36 | R3 |
| 24 | 11 | 75 | 140 | ACS880-11/31-025A-3 | B84143V0025R229 | IP00/IP21 | 355 | 500 | 120 | 200 | 285 | 360 | 12.1 | 36 | R3 |
| 31 | 15 | 75 | 160 | ACS880-11/31-032A-3 | B84143V0033R229 | IP00/IP21 | 355 | 500 | 120 | 200 | 285 | 360 | 12.1 | 36 | R6 |
| 37 | 18.5 | 78 | 220 | ACS880-11/31-038A-3 | B84143V0050R229 | IP00/IP21 | 400 | 650 | 140 | 350 | 360 | 460 | 20.2 | 104.7 | R6 |
| 43 | 22 | 78 | 220 | ACS880-11/31-045A-3 | B84143V0050R229 | IP00/IP21 | 400 | 650 | 140 | 350 | 360 | 460 | 20.2 | 104.7 | R6 |
| 58 | 30 | 78 | 250 | ACS880-11/31-061A-3 | B84143V0066R229 | IP00/IP21 | 400 | 650 | 147 | 350 | 360 | 460 | 21.2 | 104.7 | R6 |
| 64 | 37 | 79 | 310 | ACS880-11/31-072A-3 | B84143V0075R229 | IP00/IP21 | 400 | 650 | 173 | 350 | 360 | 460 | 24.9 | 104.7 | R6 |
| 77 | 45 | 79 | 400 | ACS880-11/31-087A-3 | B84143V0095R229 | IP00/IP21 | 440 | 700 | 164 | 350 | 500 | 580 | 36.1 | 142.1 | R6 |
| 91 | 55 | 80 | 600 | ACS880-11/31-105A-3 | B84143V0130S230 | IP00/IP21 | 565 | 850 | 300 | 480 | 420 | 500 | 71.2 | 204 | R8 |
| 126 | 75 | 80 | 550 | ACS880-11/31-145A-3 | B84143V0162S229 | IP00/IP21 | 500 | 730 | 300 | 400 | 380 | 430 | 57 | 125.6 | R8 |
| 153 | 90 | 80 | 550 | ACS880-11/31-169A-3 | B84143V0162S229 | IP00/IP21 | 500 | 730 | 300 | 400 | 380 | 430 | 57 | 125.6 | R8 |
| 187 | 110 | 80 | 900 | ACS880-11/31-206A-3 | B84143V0230S229 | IP00/IP21 | 570 | 850 | 285 | 480 | 430 | 500 | 69.9 | 204 | R8 |

ACS880-11 and ACS880-31 wall-mounted regenerative and ultra-low harmonic drives, sine filters

| I_N (A) | $P_N^{1)}$ (kW) | Noise level ²⁾ (dB) | Heat dissipation ²⁾ (W) | Drive type | Filter type | Degree of protection | Filter width | | Filter depth | | Filter height | | Filter weight | | Frame size |
|---|--------------------|-----------------------------------|---------------------------------------|---------------------|-----------------|----------------------|--------------|--------------|--------------|--------------|---------------|--------------|---------------|--------------|------------|
| | | | | | | | IP00 (mm) | IP21 (mm) | IP00 (mm) | IP21 (mm) | IP00 (mm) | IP21 (mm) | IP00 (kg) | IP21 (kg) | |
| $U_N = 500$ V (range 380 to 500 V). The power ratings are valid at nominal voltage 500 V. | | | | | | | | | | | | | | | |
| 7 | 4 | 72 | 90 | ACS880-11/31-07A6-5 | B84143V0011R229 | IP00/IP21 | 235 | 384 | 110 | 152 | 200 | 246 | 5.2 | 14.4 | R3 |
| 10.2 | 5.5 | 72 | 90 | ACS880-11/31-11A0-5 | B84143V0011R229 | IP00/IP21 | 235 | 384 | 110 | 152 | 200 | 246 | 5.2 | 14.4 | R3 |
| 13 | 7.5 | 70 | 80 | ACS880-11/31-014A-5 | B84143V0016R229 | IP00/IP21 | 275 | 420 | 122 | 200 | 235 | 290 | 7.9 | 24.4 | R3 |
| 20 | 11 | 75 | 140 | ACS880-11/31-021A-5 | B84143V0025R229 | IP00/IP21 | 355 | 500 | 120 | 200 | 285 | 360 | 12.1 | 36 | R3 |
| 25 | 15 | 75 | 160 | ACS880-11/31-027A-5 | B84143V0033R229 | IP00/IP21 | 355 | 500 | 120 | 200 | 285 | 360 | 12.1 | 36 | R6 |
| 32 | 18.5 | 78 | 220 | ACS880-11/31-034A-5 | B84143V0050R229 | IP00/IP21 | 400 | 650 | 140 | 350 | 360 | 460 | 20.2 | 104.7 | R6 |
| 35 | 22 | 78 | 220 | ACS880-11/31-040A-5 | B84143V0050R229 | IP00/IP21 | 400 | 650 | 140 | 350 | 360 | 460 | 20.2 | 104.7 | R6 |
| 44 | 30 | 78 | 250 | ACS880-11/31-052A-5 | B84143V0066R229 | IP00/IP21 | 400 | 650 | 147 | 350 | 360 | 460 | 21.2 | 104.7 | R6 |
| 52 | 37 | 78 | 250 | ACS880-11/31-065A-5 | B84143V0066R229 | IP00/IP21 | 400 | 650 | 147 | 350 | 360 | 460 | 21.2 | 104.7 | R6 |
| 61 | 37 | 78 | 310 | ACS880-11/31-077A-5 | B84143V0075R229 | IP00/IP21 | 400 | 650 | 173 | 350 | 360 | 460 | 24.9 | 104.7 | R6 |
| 80 | 55 | 80 | 630 | ACS880-11/31-096A-5 | B84143V0130S230 | IP00/IP21 | 565 | 850 | 300 | 480 | 420 | 500 | 71.2 | 204 | R8 |
| 104 | 55 | 80 | 630 | ACS880-11/31-124A-5 | B84143V0130S230 | IP00/IP21 | 565 | 850 | 300 | 480 | 420 | 500 | 71.2 | 204 | R8 |
| 140 | 90 | 80 | 550 | ACS880-11/31-156A-5 | B84143V0162S229 | IP00/IP21 | 500 | 730 | 300 | 400 | 380 | 430 | 57 | 125.6 | R8 |
| 161 | 110 | 80 | 550 | ACS880-11/31-180A-5 | B84143V0162S229 | IP00/IP21 | 500 | 730 | 300 | 400 | 380 | 430 | 57 | 125.6 | R8 |

Nominal ratings

| | |
|-------|---|
| I_N | Rated current of the drive-filter combination available continuously without overload at 40 °C. |
| P_N | Typical motor power |

¹⁾ Please note that sine filters cause a voltage drop, reducing the available shaft power from the motor.

²⁾ Noise level is a combined value for the drive and the filter. Heat dissipation is a value for the filter.

For further information please contact your local ABB office.

ACS880-04/14/34 module packages and ACS880-104 multidrive modules, sine filters

Sine filters are available also for ACS880-04/14/34 high power single drive module packages and for ACS880-104 multidrive modules in frame size R8i. Please contact your local ABB office for further information.

ACS880-17 and ACS880-37 cabinet-built regenerative and ultra-low harmonic drives, sine filters

| I_N | $P_N^{1)}$ | Noise level ²⁾ | Heat dissipation ³⁾ | Air flow | Drive type | Filter type | Degree of protection | Filter height | Filter width | Filter depth | Filter weight | Frame size |
|--|------------|---------------------------|--------------------------------|---------------------|----------------------|-----------------|----------------------|---------------|--------------|--------------|---------------|------------|
| (A) | (kW) | (dB) | (kW) | (m ³ /h) | | | | (mm) | (mm) | (mm) | (kg) | |
| $U_N = 400$ V (range 380 to 415 V). The power ratings are valid at nominal voltage 400 V.⁴⁾ | | | | | | | | | | | | |
| 91 | 55 | 70 | 0.6 | 700 | ACS880-17/37-0105A-3 | B84143V0130R230 | IP22 | 2145 | 600 | 646 | 330 | R8 |
| 126 | 75 | 70 | 0.55 | 700 | ACS880-17/37-0145A-3 | B84143V0162S229 | IP22 | 2145 | 600 | 646 | 330 | R8 |
| 153 | 90 | 70 | 0.55 | 700 | ACS880-17/37-0169A-3 | B84143V0162S229 | IP22 | 2145 | 600 | 646 | 330 | R8 |
| 187 | 110 | 70 | 0.9 | 805 | ACS880-17/37-0206A-3 | B84143V0230S229 | IP22 | 2145 | 600 | 646 | 330 | R8 |
| 264 | 160 | 77 | 1.6 | 2100 | ACS880-17/37-0293A-3 | B84143V0390S229 | IP22 | 2145 | 600 | 646 | 430 | R11 |
| 327 | 200 | 77 | 1.6 | 2100 | ACS880-17/37-0363A-3 | B84143V0390S229 | IP22 | 2145 | 600 | 646 | 430 | R11 |
| 398 | 250 | 77 | 1.7 | 2100 | ACS880-17/37-0442A-3 | B84143V0390S229 | IP22 | 2145 | 600 | 646 | 430 | R11 |
| 455 | 250 | 80 | 3.0 | 2000 | ACS880-17/37-0505A-3 | NSIN0900-6 | IP22 | 2145 | 1000 | 646 | 840 | R11 |
| 527 | 315 | 80 | 3.4 | 2000 | ACS880-17/37-0585A-3 | NSIN0900-6 | IP22 | 2145 | 1000 | 646 | 840 | R11 |
| 585 | 355 | 80 | 3.8 | 2000 | ACS880-17/37-0650A-3 | NSIN0900-6 | IP22 | 2145 | 1000 | 646 | 840 | R11 |

ACS880-17 and ACS880-37 cabinet-built regenerative and ultra-low harmonic drives, sine filters

| I_N | $P_N^{1)}$ | Noise level ²⁾ | Heat dissipation ³⁾ | Air flow | Drive type | Filter type | Degree of protection | Filter height | Filter width | Filter depth | Filter weight | Frame size |
|--|------------|---------------------------|--------------------------------|---------------------|----------------------|-----------------|----------------------|---------------|--------------|--------------|---------------|------------|
| (A) | (kW) | (dB) | (kW) | (m ³ /h) | | | | (mm) | (mm) | (mm) | (kg) | |
| $U_N = 500$ V (range 380 to 500 V). The power ratings are valid at nominal voltage 500 V.⁴⁾ | | | | | | | | | | | | |
| 80 | 45 | 70 | 0.6 | 700 | ACS880-17/37-0101A-5 | B84143V0130S230 | IP22 | 2145 | 600 | 646 | 330 | R8 |
| 104 | 55 | 70 | 0.6 | 700 | ACS880-17/37-0124A-5 | B84143V0130S230 | IP22 | 2145 | 600 | 646 | 330 | R8 |
| 140 | 75 | 70 | 0.6 | 700 | ACS880-17/37-0156A-5 | B84143V0162S229 | IP22 | 2145 | 600 | 646 | 330 | R8 |
| 161 | 90 | 70 | 0.6 | 805 | ACS880-17/37-0180A-5 | B84143V0162S229 | IP22 | 2145 | 600 | 646 | 330 | R8 |
| 234 | 160 | 77 | 0.9 | 2100 | ACS880-17/37-0260A-5 | B84143V0230S229 | IP22 | 2145 | 600 | 646 | 340 | R11 |
| 325 | 200 | 77 | 1.6 | 2100 | ACS880-17/37-0361A-5 | B84143V0390S229 | IP22 | 2145 | 600 | 646 | 430 | R11 |
| 373 | 250 | 77 | 1.6 | 2100 | ACS880-17/37-0414A-5 | B84143V0390S229 | IP22 | 2145 | 600 | 646 | 430 | R11 |
| 414 | 315 | 80 | 3.3 | 2000 | ACS880-17/37-0460A-5 | NSIN0900-6 | IP22 | 2145 | 1000 | 646 | 840 | R11 |
| 453 | 355 | 80 | 3.6 | 2000 | ACS880-17/37-0503A-5 | NSIN0900-6 | IP22 | 2145 | 1000 | 646 | 840 | R11 |

ACS880-17 and ACS880-37 cabinet-built regenerative and ultra-low harmonic drives, sine filters

| I_N | $P_N^{1)}$ | Noise level ²⁾ | Heat dissipation ³⁾ | Air flow | Drive type | Filter type | Degree of protection | Filter height | Filter width | Filter depth | Filter weight | Frame size |
|--|------------|---------------------------|--------------------------------|---------------------|----------------------|-----------------|----------------------|---------------|--------------|--------------|---------------|------------|
| (A) | (kW) | (dB) | (kW) | (m ³ /h) | | | | (mm) | (mm) | (mm) | (kg) | |
| $U_N = 690$ V (range 525 to 690 V). The power ratings are valid at nominal voltage 690 V.⁴⁾ | | | | | | | | | | | | |
| 157 | 160 | 77 | 0.9 | 2100 | ACS880-17/37-0174A-7 | B84143V0207S230 | IP22 | 2145 | 600 | 646 | 410 | R11 |
| 189 | 200 | 77 | 0.9 | 2100 | ACS880-17/37-0210A-7 | B84143V0207S230 | IP22 | 2145 | 600 | 646 | 410 | R11 |
| 244 | 250 | 77 | 0.9 | 2100 | ACS880-17/37-0271A-7 | B84143V0207S230 | IP22 | 2145 | 600 | 646 | 410 | R11 |
| 297 | 315 | 80 | 2.2 | 700 | ACS880-17/37-0330A-7 | NSIN0485-6 | IP22 | 2145 | 400 | 646 | 340 | R11 |
| 333 | 355 | 80 | 2.3 | 700 | ACS880-17/37-0370A-7 | NSIN0485-6 | IP22 | 2145 | 400 | 646 | 340 | R11 |
| 387 | 400 | 80 | 2.4 | 700 | ACS880-17/37-0430A-7 | NSIN0485-6 | IP22 | 2145 | 400 | 646 | 340 | R11 |

¹⁾ Please note that sine filters cause a voltage drop, reducing the available shaft power from the motor.

²⁾ Noise level is a combined value for the drive and the filter.

³⁾ Heat dissipation is a combined value for the drive and the filter, except for frame sizes R8 and R11 the heat dissipation value is for the filter only.

⁴⁾ Higher powers available as application engineered (+P902).

Sine filters for larger types are available as customized option.

For further information please contact your local ABB office.



H

EMC

What is EMC?

EMC stands for electromagnetic compatibility. It is the ability of electrical/electronic equipment to operate without problems in an electromagnetic environment.

Likewise, the equipment must not disturb or interfere with any other product or system in its locality. This is a legal requirement for all equipment taken into service within the European Economic Area (EEA).

Installation environments

A power drive system (PDS) can be connected to either industrial or public power distribution networks. The environment class depends on the way the PDS is connected to power supply.

The **1st environment** includes domestic premises. It also includes establishments directly connected without an intermediate transformer to a low voltage power supply network that supplies buildings used for domestic purposes.

The **2nd environment** includes all establishments directly connected to public low voltage power supply networks.

EMC solutions

To fulfill the EMC requirements, the drives are equipped with standard or optional RFI filtering for HF disturbances.

- Using ferrite rings in power connection points
- Using an AC or DC choke (while they are meant to protect against harmonics, they reduce HF disturbances as well)
- Using an LCL filter in the case of regenerative drives
- Using a du/dt filter

Immunity and emission compatibility

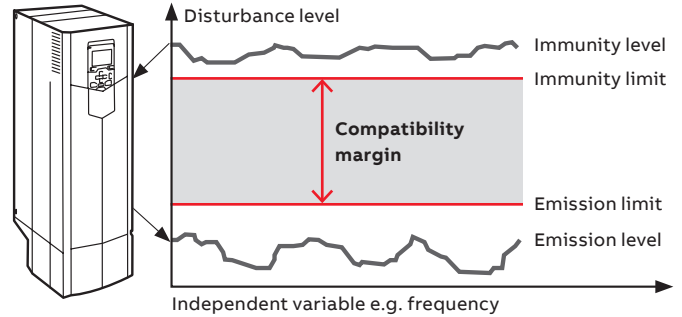

Installation environments

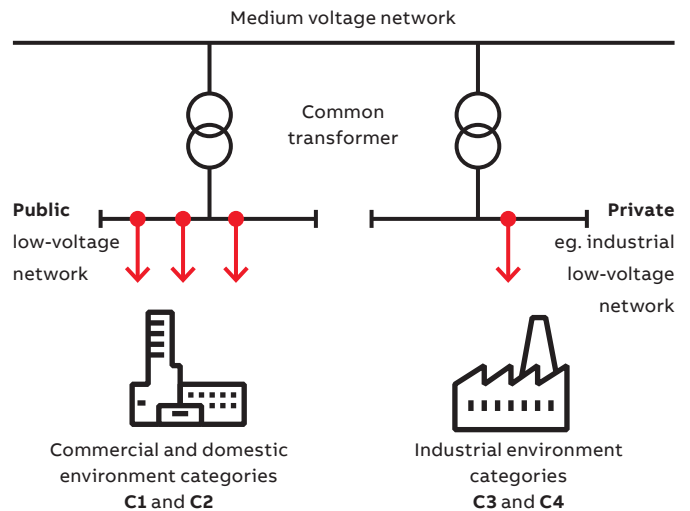

The product standard EN 61800-3 divides PDSs into four categories according to the intended use

C1 – 1st environment

- Household appliances
- Usually plug connectable to any wall outlet
- Anyone can connect these to the network
- Examples: washing machines, TV sets, computers, microwave ovens, etc.

C2 – 1st environment

- Fixed household and public appliances
- Need to be installed or operated by a professional
- Examples: elevators, rooftop fans, residential booster pumps, gates and barriers, supermarket freezers, etc.

C3 – 2nd environment

- Professional equipment
- Needs to be installed or operated by a professional
- In some rare cases, may also be pluggable
- Examples: any equipment for industrial usage only, such as conveyors, mixers, etc.

C4 – 2nd environment

- Professional equipment
- Needs to be fixed installation and operated by a professional
- Examples: paper machines, rolling mills, etc.

Comparison of EMC standards

| EN 61800-3, product standard | EN 61800-3, product standard | EN 55011, product family standard for industrial, scientific and medical (ISM) equipment | EN 61000-6-4, generic emission standard for industrial environments | EN 61000-6-3, generic emission standard for residential, commercial and light-industrial environment |
|------------------------------|--|--|---|--|
| Category C1 | 1 st environment, unrestricted distribution | Group 1. Class B | Not applicable | Applicable |
| Category C2 | 1 st environment, restricted distribution | Group 1. Class A | Applicable | Not applicable |
| Category C3 | 2 nd environment, unrestricted distribution | Group 2. Class A | Not applicable | Not applicable |
| Category C4 | 2 nd environment, restricted distribution | Not applicable | Not applicable | Not applicable |

EMC compliance

| Drive type | Voltage (V) | Frame size | 1 st environment, C1 unrestricted distribution, grounded network (TN) | 1 st environment, C2 restricted distribution, grounded network (TN) | 2 nd environment, C3 unrestricted distribution, grounded network (TN) | 2 nd environment, C3 unrestricted distribution, ungrounded network (IT) | 2 nd environment, C4 restricted distribution, ungrounded network (IT) | 2 nd environment, C4 restricted distribution, grounded network (TN) |
|---------------------------|-------------|---------------|---|---|---|---|---|---|
| ACS380 | 200-240 | R0...R4 | With external filter | ACS380-042x | - | - | - | ACS380-040x |
| ACS380 | 380-480 | R0...R4 | With external filter | ACS380-042x | ACS380-040x | ACS380-040x | ACS380-040x | - |
| ACS480 | 380-480 | R1...R4 | With external filter | Standard | Standard | Standard | - | - |
| ACS580-01 | 380-480 | R1...R5 | +E223 (IP55) | Standard | Standard | Standard | - | - |
| ACS580-01 | 380-480 | R6...R9 | - | Standard | Standard | Standard | - | - |
| ACS580-04 | 380-480 | R10...R11 | - | - | Standard | Standard | - | - |
| ACS580-07 | 380-480 | R6...R11 | - | Standard (R6...R9) | Standard (R10...R11) | Standard (R10...R11) | - | - |
| ACS880-01 | 380-500 | R1...R9 | - | +E202 | +E200 | +E201 (R6...R9) | +E201 (R1 to R5) | - |
| ACS880-01 | 690 | R5...R9 | - | - | +E200 (R5...R9) | +E201 (R7...R9) | +E201 (R3, R5, R6) | - |
| ACS880-04 | 380 to 500 | R10, R11 | - | +E202 | +E200 | +E201 | - | As standard |
| ACS880-04 | 525 to 690 | R10, R11 | - | - | +E200 | +E201 | - | As standard |
| ACS880-04F | 380 to 690 | R11 | - | - | +E200 | +E201 | - | As standard |
| ACS880-04FXT | 380 to 500 | n x R11 | - | EMC filter ARFI-10 is needed | +E200 | +E201 | - | As standard |
| ACS880-04FXT | 525 to 690 | n x R11 | - | - | +E200 | +E201 | - | As standard |
| ACS880-11/31 | 380 to 500 | R3, R6, R8 | - | +E202 *) | +E200 | +E201 | - | As standard |
| ACS880-14/34 | 380 to 690 | R11 | - | +E202 **) | +E200 | - | +E201 | As standard |
| ACS880-17/37 | 380 to 690 | R11 | - | +E202 ***) | +E200 | - | +E201 | As standard |
| ACS880-17/37 | 380 to 500 | R8 | - | +E202 | +E200 | +E201 | - | As standard |
| ACS880-04XT, ACS880-04FXT | 380-690 | 2 x R10...R11 | - | EMC filter ARFI-10 is needed (not for 690 V) | +E200 (690 V) | +E201 | - | As standard |
| ACS880-07 | 380-690 | R6...R11 | - | +E202 (not for 690 V) | +E200 | +E201 | +E201 (R6, 690V), Standard (R10, R11) | - |

*) Not available for R6

**) Not for 690 V

***) Please contact your local ABB

Harmonic mitigation

What are harmonics?

Harmonic currents are created by non-linear loads connected to the power distribution system. Harmonic distortion is a form of pollution in the electric plant that can cause problems if the voltage distortion caused by harmonic currents increases above certain limits.

All power electronic converters used in different types of electronic systems can increase harmonic disturbances by injecting harmonic currents directly into the grid.

Electricity supply is hardly ever a pure sine wave voltage, and current that deviates from the sine form contains harmonics. The distortion is caused by non-linear loads connected to the electrical supply. Harmonics cause disturbances and equipment failures.

The total current as the sum of the fundamental and 5th harmonics

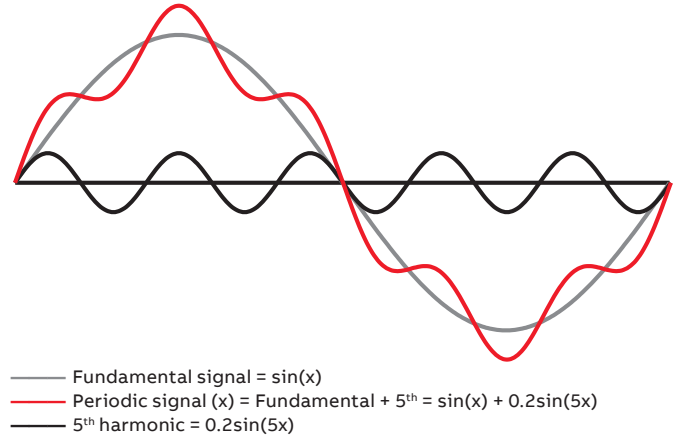

Where do the harmonics come from?

Non-linear loads such as:

- Variable speed drives
- Uninterruptible power supplies (UPS)
- Industrial rectifiers
- Welding machines
- Fluorescent lighting systems (electronic ballast)
- Computers
- Printers
- Servers
- Electronic appliances
- ...

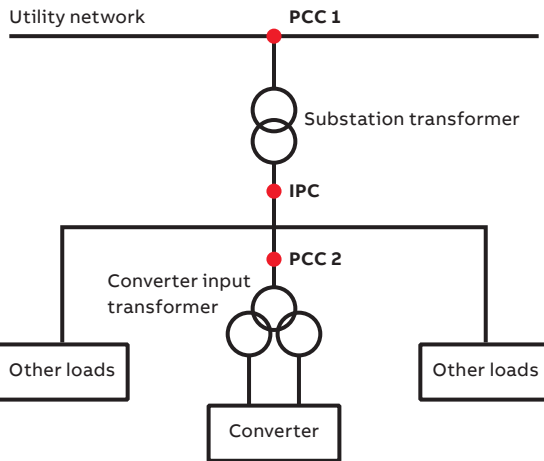

- Point of common coupling (**PCC**) is the point where the harmonic distortion is specified, e.g.
 - between the plant and the utility network (**PCC1**)
 - between the non-linear load and other loads within an industrial plant (**PCC 2**)

- In-plant point of coupling (**IPC**) is the point inside the customer system or installation to be studied

The effects of harmonic distortions

Harmonic currents

- Mainly affect the power distribution system up to the rectifier:
- Additional losses in wires and cables
 - Extra heating of transformers
 - Circuit breaker malfunctioning
 - Triplen harmonics increase the neutral current & voltage

Harmonic voltage

- Can affect other equipment connected to the electrical system:
- Erratic operation of telecommunication systems, computers, video monitors, electronic test equipment, etc.
 - Resonance with power factor correction capacitors
 - Motor derations



Reliable operation



Reduced cost



Longer lifetime

Low Harmonic solutions

- Improve filtering on the drive
 - Limited attenuation
 - Add AC or DC chokes
 - Most AC drives have chokes as standard
- Use passive filtering
 - Tuned LC filter
 - Requires reactive power to compensate
 - Diode rectifier provides very limited reactive power
 - Limits harmonic absorption
 - Must not be allowed to run to leading power factor
 - Filter can be overloaded
- Use a multi-pulse rectifier
 - Passive solution
 - Requires transformer, more economical when used with step down to avoid oversizing of LV system and losses of 2 transformers
 - Minimum size limitations
- Use an electronic solution
 - Integrated into the inverter with an active rectifier
 - Integrated into the LV system
 - AHF can be retrofitted to existing LV systems

Drive system features affecting harmonics

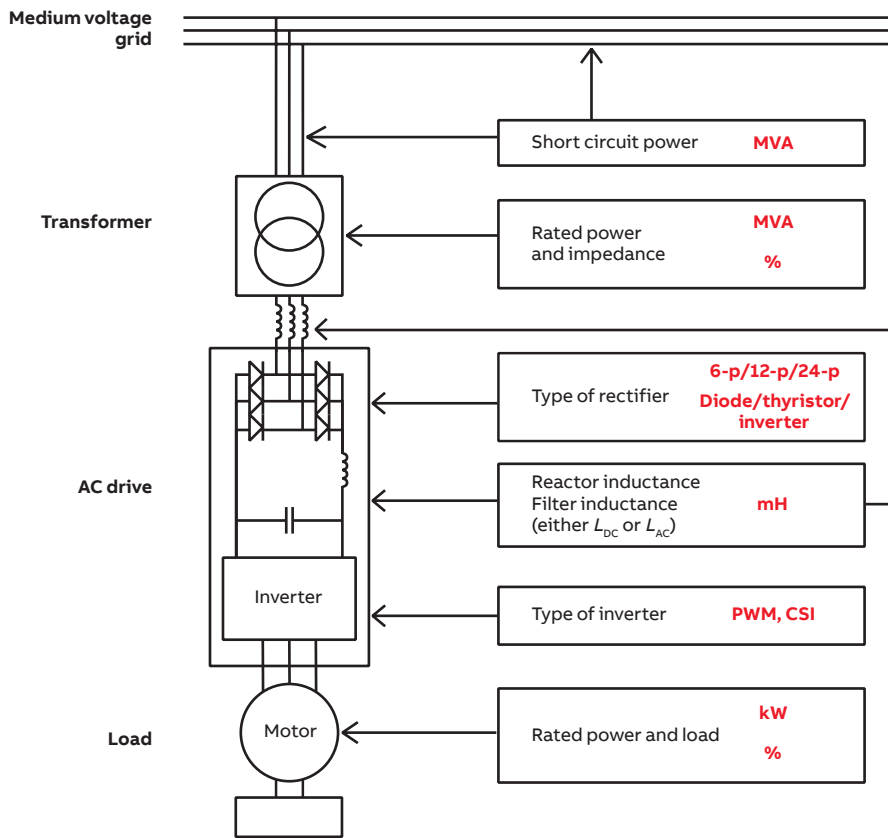

Harmonics reduction can be achieved either by structural modifications in the drive system or by using external filtering. The structural modifications may be to strengthen the supply, or to use 12 or more pulse drives, to use a controlled rectifier, or to improve the internal filtering in the drive.

The image to the left shows the factors in the AC drive system that have some influence on harmonics. The current harmonics depend on the drive construction, and the voltage harmonics are the current harmonics multiplied by the supply impedances.

Control unit – Default I/O connections

ACS380

The ACS380 machinery drives offer three different standard interfaces: the standard variant (I/O and Modbus), the basic drive unit variant, and the configured variant with different interfaces. In addition, the drive has one option slot available that can be used for speed feedback, relay extensions or options which allow an external +24V supply.

The standard variant (ACS380-04xS - I/O and Modbus)

Available, and easy to order

- 4 DI + 2 DIO + 2 AI + 1 AO + 3 RO + STO
- Embedded Modbus RTU

ACS380-04xS

Default I/O connections of standard variant

| Terminals | Descriptions |
|--|---|
| Aux. voltage output and digital connections | |
| +24 V | Aux. voltage output +24 V DC, max. 200 mA |
| DGND | Aux. voltage output common |
| DCOM | Digital input common for all |
| DI 1 | Digital input 1: Stop (0)/Start (1) |
| DI 2 | Digital input 2: Forward (0)/Reverse (1) |
| DI 3 | Digital input 3: Speed selection |
| DI 4 | Digital input 4: Speed selection |
| DIO 1 | Digital output function: Ramp set 1 (0)/Ramp set 2 (1) |
| DIO 2 | Digital output function: Ready to run (0)/Not ready (1) |
| DIO SRC | Signal cable shield (screen) |
| DIO COM | Digital input common for all |
| Reference voltage and analog I/O | |
| AI 1 | Output frequency/Speed reference (0...10 V) |
| AGND | Analog input circuit common |
| AI 2 | Not configured |
| AGND | Analog input circuit common |
| AO | Output frequency (0...20 mA) |
| AGND | Analog output circuit common |
| SCR | Signal cable shield (screen) |
| +10 V | Reference voltage |
| Relay output | |
| RC | Fault (-1) |
| RA | 250 V AC/30 V DC |
| RB | 2 A |
| Safe torque off (STO) | |
| S+ | Safe torque off. Both circuits must be closed for the drive to start. The circuits are closed with jumper wires in the standard delivery. |
| SGND | |
| S 1 | |
| S 2 | |
| EIA-485 Modbus RTU | |
| B+ | Embedded Modbus RTU (EIA-485) |
| A- | |
| BGND | |
| Shield | |
| Termination | |

Default I/O connections of standard variant (ACS380-04xS)

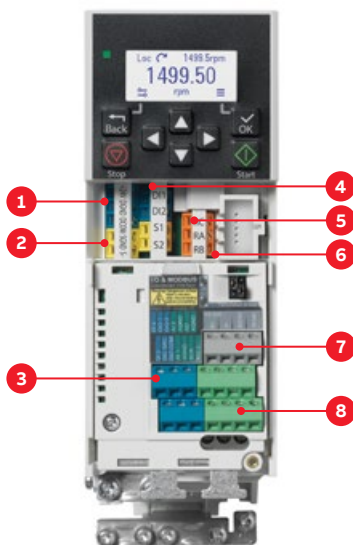

1. Auxiliary voltage outputs
2. Safe torque off connections
3. Digital inputs and outputs
4. Digital inputs
5. Relay output connection
6. Cold configuration connection for CCA-01
7. EIA-485 Modbus RTU
8. Analog inputs and outputs

Basic drive unit variant (ACS380-04xN)

Configurations is generated by installing the customer desired options, and ordered separately as loose items

- 2 DI + 1 RO + STO

Configured variant (ACS380-04xC)

Built-in by ABB according to the customer specification, preinstalled with single ordering code

- 2 DI + 1 RO + STO + one preconfigured fieldbus

Options:

• **Fieldbus options**

PROFIBUS, PROFINET, EtherNet/IP™, Modbus TCP/IP, EtherCAT®, POWERLINK, DeviceNet™, CanOpen®, PROFIsafe

• **One of following side extension options**

- HTL/TTL encoder & ext. 24 V DC supply
- 4 x relay output module
- External 24 V DC supply

• **One front extension I/O option**

can be used together with fieldbus
3 DI + 1 DO + 1 AI

ACS380-04xN, -04xC

Default connections of configured variant

| Terminals | Descriptions | |
|---|---|-------|
| Aux. voltage output and digital connections | | |
| +24 V | Aux. voltage output +24 V DC, max. 200 mA | |
| DGND | Aux. voltage output common | |
| DCOM | Digital input common for all | |
| DI 1 | Digital input 1: Stop (0)/Start (1) | |
| DI 2 | Digital input 2: Forward (0)/Reverse (1) | |
| Relay output | | |
| RC | Fault (-1) | |
| RA | 250 V AC/30 V DC | |
| RB | 2 A | |
| Safe torque off (STO) | | |
| S+ | Safe torque off. Both circuits must be closed for the drive to start. The circuits are closed with jumper wires in the standard delivery. | |
| SGND | | |
| S 1 | | |
| S 2 | | |
| Extension module connections with different Fieldbus options for configured variants | | |
| DSUB9 | PROFIBUS | +K454 |
| DSUB9 | CANopen® | +K457 |
| RJ-45 x2 | EtherCAT® | +K469 |
| RJ-45 x2 | Ethernet POWERLINK | +K470 |
| RJ-45 x2 | Ethernet/IP™ | +K490 |
| RJ-45 x2 | Modbus TCP | +K491 |
| RJ-45 x2 | PROFINET IO | +K492 |
| Screw terminal | DeviceNet™ | +K451 |
| Screw terminal | CANopen | +K495 |
| 8P8C x2 | ControlNet | +K462 |

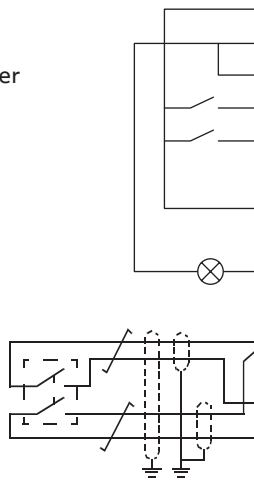

ACS380 configurant variant (ACS380-04xN)



ACS480

ACS480 drives offer a wide range of standard interfaces. In addition, the drive has one slot for either an I/O module or a fieldbus module.



- 1. Auxiliary voltage outputs
- 2. Safe torque off connections
- 3. Digital inputs and outputs
- 4. Digital inputs
- 5. Relay output connection
- 6. Cold configuration connection for CCA-01
- 7. EIA-485 Modbus RTU
- 8. Analog inputs and outputs
- 9. Additional relay output connection

The standard delivery of the ACS480 includes the I/O module. If a fieldbus adapter is needed instead, it should be ordered with a corresponding plus code.

Default factory I/O connection diagram

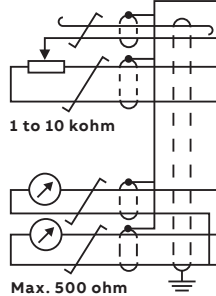

| Terminal | Meaning | Default macro connections |
|---|---------|--|
| Reference voltage and analog inputs and outputs. | | |
| 1 | SCR | Signal cable shield (screen) |
| 2 | AI1 | Output frequency/speed reference: 0...10 V¹⁾ |
| 3 | AGND | Analog input circuit common |
| 4 | +10 V | Reference voltage 10 V DC |
| 5 | AI2 | Not configured |
| 6 | AGND | Analog input circuit common |
| 7 | AO1 | Output frequency: 0...20 mA |
| 8 | AO2 | Output current: 0...20 mA |
| 9 | AGND | Analog output circuit common |

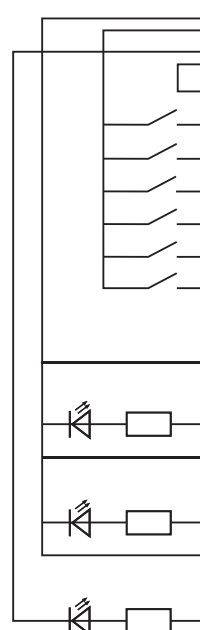

| Terminal | Meaning | Default macro connections |
|--|---------|--|
| Aux. voltage output and programmable digital inputs | | |
| 10 | +24 V | Auxiliary voltage output +24 V DC, max. 250 mA |
| 11 | DGND | Auxiliary voltage output common |
| 12 | DCOM | Digital input common for all |
| 13 | DI1 | Stop (0)/Start (1) |
| 14 | DI2 | Forward (0)/Reverse (1) |
| 15 | DI3 | Constant frequency/speed selection |
| 16 | DI4 | Constant frequency/speed selection |
| 17 | DI5 | Ramp set 1 (0)/Ramp set 2 (1) |
| 18 | DI6 | Not configured |

| Terminal | Meaning | Default macro connections |
|----------------------|---------|---------------------------|
| Relay outputs | | |
| 19 | RO1C | Ready |
| 20 | RO1A | 250 V AC/30 V DC |
| 21 | RO1B | 2 A |
| 22 | RO2C | Running |
| 23 | RO2A | 250 V AC/30 V DC |
| 24 | RO2B | 2 A |
| 25 | RO3C | Fault (-1) |
| 26 | RO3A | 250 V AC/30 V DC |
| 27 | RO3B | 2 A |

| Terminal | Meaning | Default macro connections |
|---------------------------|-----------|-------------------------------------|
| EIA-485 Modbus RTU | | |
| 29 | B+ | |
| 30 | A- | Embedded Modbus RTU (EIA-485) |
| 31 | DGND | |
| S100 | TERM&BIAS | Serial data link termination switch |

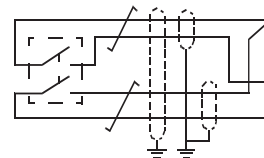

| Terminal | Meaning | Default macro connections |
|------------------------|---------|---|
| Safe torque off | | |
| 34 | SGND | |
| 35 | IN1 | Safe torque off. Both circuits must be closed for the drive to start. The circuits are closed with jumper wires in the standard delivery. |
| 36 | IN2 | |
| 37 | OUT1 | |

| Terminal | Meaning | Default macro connections |
|----------|---------|--|
| 42 | +24 V | Auxiliary voltage output. The alternative terminals have the same supply as the base unit. |
| 43 | DGND | |
| 44 | DCOM | |

ACS580-01, R1-R5

ACS580 drives offer a wide range of standard interfaces. In addition, the drive has two option slots that can be used for extensions, including fieldbus adapters and input/output extension modules that allow an external +24 V supply with frame sizes R1 to R5.

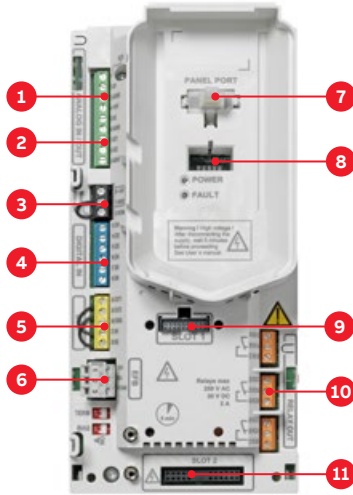

- 1. 2 Analog inputs – *current or voltage*
- 2. 2 Analog outputs – *current and voltage*
- 3. GND and DCOM terminals
- 4. 6 Digital inputs (1 pulse input)
- 5. Safe Torque Off – *SIL3 / PLe*
- 6. EIA-485 – *built-in Modbus RTU*
- 7. EIA-485 Panel port – *control panel*
- 8. ABB Drive Customizer Port – *for programming the drive without mains*
- 9. Option slot 1: fieldbus adapter module
- 10. 3 Relay outputs – *from C type*
- 11. Option slot 2: I/O extension module

- 6 DI + 2 AI + 2 AO + 3 RO
- Safe Torque OFF / STO (STO is a standard safety function, SIL3)
- Embedded modbus
- 1 I/O Extension module
- 1 Fieldbus adapter module

Default I/O connection diagram

| Terminal | Meaning | Default macro connections |
|--|---------|---|
| XI Reference voltage and analog inputs and outputs | | |
| 1 | SCR | Signal cable shield (screen) |
| 2 | AI1 | External frequency reference 1: 0 to 10 V |
| 3 | AGND | Analog input circuit common |
| 4 | +10 V | Output reference voltage 10 V DC |
| 5 | AI2 | Not used |
| 6 | AGND | Analog input circuit common |
| 7 | AO1 | Output frequency: 0 to 20 mA |
| 8 | AO2 | Output current: 0 to 20 mA |
| 9 | AGND | Analog output circuit common |
| X2 & X3 Aux. voltage output and programmable digital inputs | | |
| 10 | +24 V | Auxiliary voltage output +24 V DC |
| 11 | DGND | Auxiliary voltage output common |
| 12 | DCOM | Digital input common for all DI |
| 13 | DI1 | Start/Stop: Activate to start |
| 14 | DI2 | Fwd/Rev: Activate to reverse rotation direction |
| 15 | DI3 | Constant speed selection |
| 16 | DI4 | Constant speed selection |
| 17 | DI5 | Ramp pair selection: Activate to select second pair |
| 18 | DI6 | Not used |
| X6, X7, X8 Relay outputs | | |
| 19 | RO1C | Ready |
| 20 | RO1A | 250 V AC/30 V DC |
| 21 | RO1B | 2 A |
| 22 | RO2C | Running |
| 23 | RO2A | 250 V AC/30 V DC |
| 24 | RO2B | 2 A |
| 25 | RO3C | Fault (-1) |
| 26 | RO3A | 250 V AC/30 V DC |
| 27 | RO3B | 2 A |
| X5 EIA-485 Modbus RTU | | |
| 29 | B+ | |
| 30 | A- | Built-in Modbus RTU fieldbus interface |
| 31 | DGND | |
| X4 Safe torque off | | |
| 34 | OUT1 | |
| 35 | OUT2 | Safe torque off. Both circuits must be closed for the drive to start. The circuits are closed with jumper wires in the standard delivery. |
| 36 | SGND | |
| 37 | IN1 | |
| 38 | IN2 | |
| X10*) 24 V AC/DC | | |
| 40 | 24 V | AC/DC-in. ext. 24 V AC/DC input to power up the control unit when the main supply is disconnected |
| 41 | 24 V | AC/DC+in. |

*) Terminals 40-41 are integrated in frame sizes R6-R11. For frame sizes R1-R5, I/O options (+L) are needed.

ACS580-01 (R6-R9), ACS580-04, ACS580-07

Default I/O connection diagram

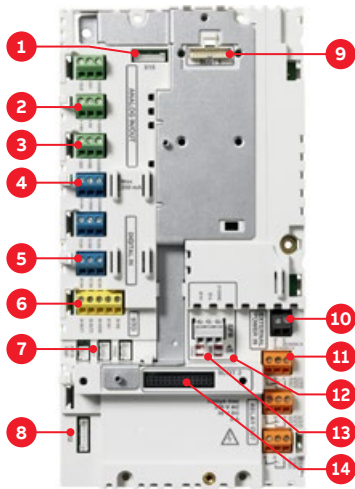

- 1. Reserved for internal use
- 2. Analog inputs
- 3. Analog outputs
- 4. Auxiliary voltage output
- 5. Digital inputs
- 6. Safe torque off connection
- 7. Internal fan 1 & 2 connection
- 8. Panel port – control panel connection, wired at the factory to the control panel
- 9. Option slot 1: fieldbus adapter module
- 10. 24 V AC/DC external power input
- 11. 3 x Relay output
- 12. End termination switch
- 13. Bias resistor switch
- 14. Option slot 2: I/O extension module

- 6 DI + 2 AI + 2 AO + 3 RO
- Safe Torque OFF / STO (STO is a standard safety function, SIL3)
- Embedded modbus
- 1 I/O Extension module
- 1 Fieldbus adapter module

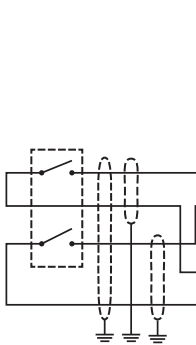
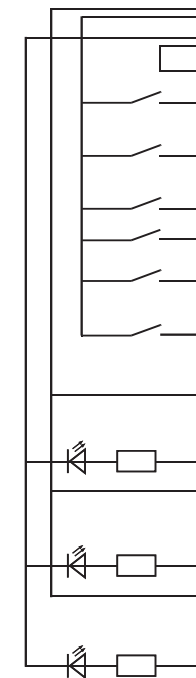
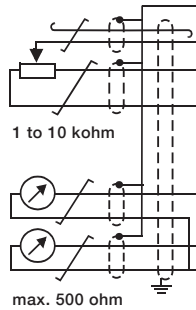

| Terminal | Meaning | Default macro connections |
|--|---------|---|
| XI Reference voltage and analog inputs and outputs | | |
| 1 | SCR | Signal cable shield (screen) |
| 2 | AI1 | External frequency reference 1: 0 to 10 V |
| 3 | AGND | Analog input circuit common |
| 4 | +10 V | Output reference voltage 10 V DC |
| 5 | AI2 | Not used |
| 6 | AGND | Analog input circuit common |
| 7 | AO1 | Output frequency: 0 to 20 mA |
| 8 | AO2 | Output current: 0 to 20 mA |
| 9 | AGND | Analog output circuit common |
| X2 & X3 Aux. voltage output and programmable digital inputs | | |
| 10 | +24 V | Auxiliary voltage output +24 V DC |
| 11 | DGND | Auxiliary voltage output common |
| 12 | DCOM | Digital input common for all DI |
| 13 | DI1 | Start/Stop: Activate to start |
| 14 | DI2 | Fwd/Rev: Activate to reverse rotation direction |
| 15 | DI3 | Constant speed selection |
| 16 | DI4 | Constant speed selection |
| 17 | DI5 | Ramp pair selection: Activate to select second pair |
| 18 | DI6 | Not used |
| X6, X7, X8 Relay outputs | | |
| 19 | RO1C | Ready |
| 20 | RO1A | 250 V AC/30 V DC |
| 21 | RO1B | 2 A |
| 22 | RO2C | Running |
| 23 | RO2A | 250 V AC/30 V DC |
| 24 | RO2B | 2 A |
| 25 | RO3C | Fault (-1) |
| 26 | RO3A | 250 V AC/30 V DC |
| 27 | RO3B | 2 A |
| X5 EIA-485 Modbus RTU | | |
| 29 | B+ | Built-in Modbus RTU fieldbus interface |
| 30 | A- | |
| 31 | DGND | |
| X4 Safe torque off | | |
| 34 | OUT1 | Safe torque off. Both circuits must be closed for the drive to start. The circuits are closed with jumper wires in the standard delivery. |
| 35 | OUT2 | |
| 36 | SGND | |
| 37 | IN1 | |
| 38 | IN2 | |
| X10*) 24 V AC/DC | | |
| 40 | 24 V | AC/DC-in. ext. 24 V AC/DC input to power up the control unit when the main supply is disconnected |
| 41 | 24 V | AC/DC+in. |

*) Terminals 40-41 are integrated in frame sizes R6-R11. For frame sizes R1-R5, I/O options (+L) are needed.

**ACS880-01, ACS880-07 (R6-R9),
ACS880-11, ACS880-31,
ACS880-17 (R8), ACS880-37 (R8)**

The ACS880 single drives offer a wide range of standard interfaces. In addition, the drives have three option slots that can be used for extensions, including fieldbus adapter modules, input/output extension modules (that allow external +24 V supply with frames R1 to R4), feedback modules and a safety functions module.

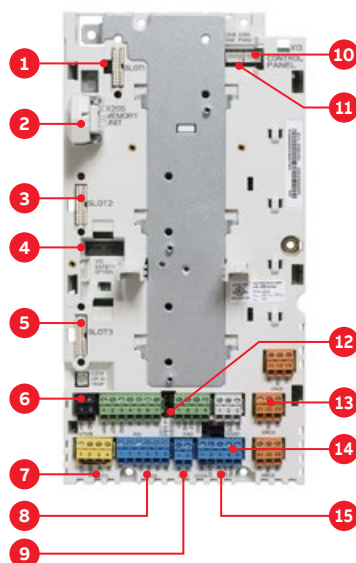

1. Option slot 1 – feedback interface modules and fieldbus communication modules can be inserted into slots 1, 2 and 3
2. Memory unit connection
3. Option slot 2
4. Connector for safety function modules (optional)
5. Option slot 3
6. External power input
7. Safe torque off connection
8. Digital inputs
9. Digital inputs/outputs
10. Control panel connection
11. Auxiliary cooling fan connection
12. Voltage/current selection jumpers (J1, J2) for analog inputs
13. 3 x Relay output
14. Drive-to-drive link termination jumper (J3), common digital input ground selection jumper (J6)
15. Start interlock connection (DIIL) and +24 V output

- 6 DI + 2 DI/DO + 2 AI + 2 AO + 3 RO
- Safe Torque Off / STO (STO is a standard safety function, SIL3)
- Embedded modbus
- 3 option slots: encoder feedback interface modules / fieldbus communication modules / I/O modules

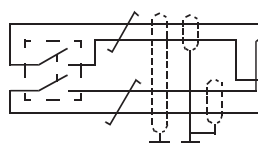
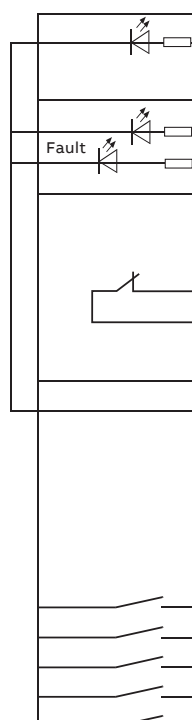
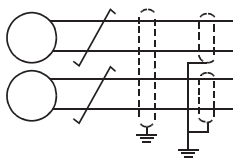
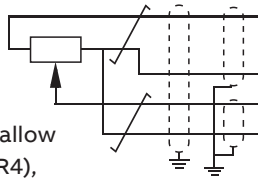

Default I/O connection diagram

| XPOW | | External power input | |
|------------------|-------------------------|---|--|
| 1 | +24VI | 24 V DC, 2 A | |
| 2 | GND | | |
| XAI | | Reference voltage and analog inputs | |
| 1 | +VREF | 10 V DC, R_L 1 to 10 kohm | |
| 2 | -VREF | -10 V DC, R_L 1 to 10 kohm | |
| 3 | AGND | Ground | |
| 4 | AI1+ | Speed reference | |
| 5 | AI1- | 0(2) to 10 V, R_{in} > 200 kohm | |
| 6 | AI2+ | By default not in use. | |
| 7 | AI2- | 0(4) to 20 mA, R_{in} > 100 ohm | |
| J1 | J1 | AI1 current/voltage selection jumper | |
| J2 | J2 | AI2 current/voltage selection jumper | |
| XAO | | Analog outputs | |
| 1 | AO1 | Motor speed rpm 0 to 20 mA, R_L < 500 ohm | |
| 2 | AGND | | |
| 3 | AO2 | Motor current 0 to 20 mA, R_L < 500 ohm | |
| 4 | AGND | | |
| XD2D | | Drive-to-drive link | |
| 1 | B | | |
| 2 | A | Drive-to-drive link or built-in Modbus | |
| 3 | BGND | | |
| J3 | J3 | Drive-to-drive link termination switch | |
| XRO1, XRO2, XRO3 | | Relay outputs | |
| 11 | NC | Ready 250 V AC/30 V DC 2 A | |
| 12 | COM | | |
| 13 | NO | | |
| 21 | NC | Running 250 V AC/30 V DC 2 A | |
| 22 | COM | | |
| 23 | NO | | |
| 31 | NC | Faulted (-) 250 V AC/30 V DC 2 A | |
| 32 | COM | | |
| 33 | NO | | |
| XD24 | | Digital interlock | |
| 1 | DIIL | Digital interlock | |
| 2 | +24VD | +24 V DC 200 mA | |
| 3 | DICOM | Digital input ground | |
| 4 | +24VD | +24 V DC 200 mA | |
| 5 | DIOGND | Digital input/output ground | |
| J6 | Ground selection switch | | |
| XDIO | | Digital input/outputs | |
| 1 | DIO1 | Output: Ready | |
| 2 | DIO2 | Output: Running | |
| XDI | | Digital inputs | |
| 1 | DI1 | Stop (0)/Start (1) | |
| 2 | DI2 | Forward (0)/Reverse (1) | |
| 3 | DI3 | Reset | |
| 4 | DI4 | Acceleration and deceleration select | |
| 5 | DI5 | Constant speed 1 (1=On) | |
| 6 | DI6 | Not in use by default | |
| XSTO | | Safe torque off | |
| 1 | OUT1 | Safe torque off. Both circuits must be closed for the drive to start. The circuits are closed with jumper wires in the standard delivery. | |
| 2 | SGND | | |
| 3 | IN1 | | |
| 4 | IN2 | | |
| X12 | | Safety functions module connection | |
| X13 | | Control panel connection | |
| X205 | | Memory unit connection | |

**ACS880-04,
ACS880-07 (R10-R11),
ACS880-14,
ACS880-34,
ACS880-17 (R11),
ACS880-37 (R11)**

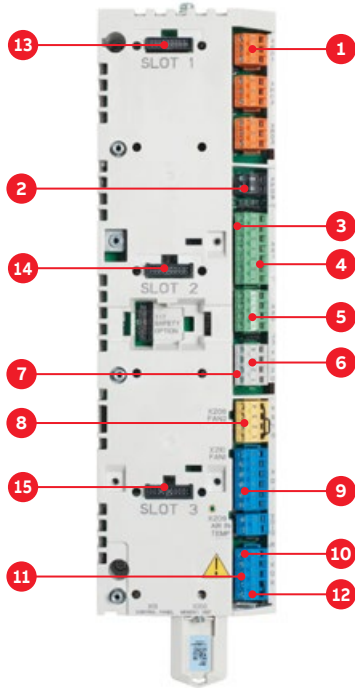

1. 3 x Relay output *)
2. External power input
3. Voltage/Current selection jumpers (J1, J2) for analog inputs
4. Analog inputs *)
5. Analog outputs *)
6. Drive-to-drive link termination jumper
7. Drive to drive link
8. Safe torque off connection
9. Digital inputs *)
10. Digital inputs/outputs *)
11. Common digital input ground selection jumper (J6)
12. Start interlock connection (DIIL)* and +24 V output
13. Option slot 1 – feedback interface modules and fieldbus communication modules can be inserted into slots 1, 2 and 3
14. Option slot 2
15. Option slot 3

*) Programmable

- 6 DI + 2 DI/DO + 2 AI + 2 AO + 3 RO
- Safe Torque OFF / STO (STO is a standard safety function, SIL3)
- Embedded modbus
- 3 option slots: encoder/feedback interface modules / fieldbus communication modules/ I/O modules

Default I/O connection diagram

| Relay outputs | | XRO1, XRO2, XRO3 | |
|---|-----------------------------------|------------------|--|
| Ready 250 V AC/30 V DC 2 A | NO | 13 | |
| | COM | 12 | |
| | NC | 11 | |
| Running 250 V AC/30 V DC 2 A | NO | 23 | |
| | COM | 22 | |
| | NC | 21 | |
| Faulted(-1) 250 V AC/30 V DC 2 A | NO | 33 | |
| | COM | 32 | |
| | NC | 31 | |
| External power input | | XPOW | |
| 24 V DC, 2 A | GND | 2 | |
| | +24VI | 1 | |
| Reference voltage and analog inputs | | J1, J2, XAI | |
| AI1/AI2 current/voltage selection | AI1:U | AI2:U | |
| | AI1:I | AI2:I | |
| By default not in use. 0(4) to 20 mA, R _{in} = 100 ohm | AI2- | 7 | |
| | AI2+ | 6 | |
| Speed reference 0(2) to 10 V, R _{in} > 200 kohm | AI1- | 5 | |
| | AI1+ | 4 | |
| Ground | AGND | 3 | |
| -10 V DC, R _L 1 to 10 kohm | -VREF | 2 | |
| 10 V DC, R _L 1 to 10 kohm | +VREF | 1 | |
| | | | |
| Analog outputs | | XAO | |
| Motor current 0 to 20 mA, R _L < 500 ohm | AGND | 4 | |
| | AO2 | 3 | |
| Motor speed rpm 0 to 20 mA, R _L < 500 ohm | AGND | 2 | |
| | AO1 | 1 | |
| Drive-to-drive link | | J3, XD2D | |
| Drive-to-drive link termination | ON - <input type="checkbox"/> OFF | | |
| | Shield | 4 | |
| Drive-to-drive link or built-in Modbus | BGND | 3 | |
| | A | 2 | |
| | B | 1 | |
| Safe torque off | | XSTO | |
| Safe torque off. Both circuits must be closed for the drive to start. The circuits are closed with jumper wires in the standard delivery. | IN2 | 4 | |
| | IN1 | 3 | |
| | SGND | 2 | |
| | OUT | 1 | |
| Digital inputs | | XDI | |
| By default not in use | DI6 | 6 | |
| Constant speed 1 select (1=on) | DI5 | 5 | |
| Acceleration and deceleration select | DI4 | 4 | |
| Reset | DI3 | 3 | |
| Forward (0)/Reverse (1) | DI2 | 2 | |
| Stop (0)/Start (1) | DI1 | 1 | |
| Digital input/outputs | | XDIO | |
| Output: Running | DIO2 | 2 | |
| Output: Ready | DIO1 | 1 | |
| Ground selection | | | |
| Auxiliary voltage output, digital input interlock | | XD24 | |
| Digital input/output ground | DIOGND | 5 | |
| +24 V DC 200 mA | +24VD | 4 | |
| Digital input ground | DICOM | 3 | |
| +24 V DC 200 mA | +24VD | 2 | |
| Digital interlock | DIIL | 1 | |
| Safety functions module connection | | X12 | |
| Control panel/PC connection | | X13 | |
| Memory unit connection | | X205 | |

ACS880-04XT, ACS880-04FXT

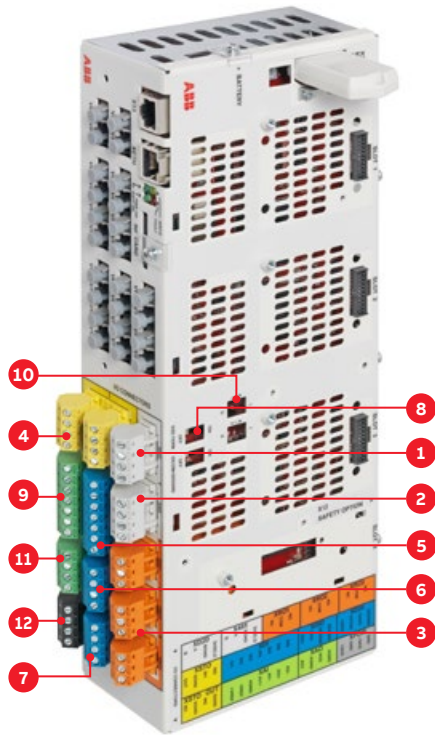

- 1. Drive-to-drive link
- 2. RS485 connection
- 3. 3 x Relay output *)
- 4. Safe torque off connection
- 5. Digital inputs *)
- 6. Digital inputs/outputs *)
- 7. Common digital input ground selection switch
- 8. Ground selection switch (DICOM)
- 9. Analog inputs *)
- 10. Voltage/Current selection switches for analog inputs
- 11. Analog outputs *)
- 12. External power input

*) Programmable

- 7 DI + 2 DI/DO + 2 AI + 2 AO + 3 RO
- Safe Torque off / STO (STO is a standard safety function, SIL3)
- Embedded modbus
- 3 option slots: encoder feedback interface modules / fieldbus communication modules/ I/O modules

Default I/O connection diagram

| Drive-to-drive link | | XD2D | |
|---------------------|--------|------|---|
| | B | | 1 |
| Drive-to-drive link | A | | 2 |
| | BGND | | 3 |
| | Shield | | 4 |

| RS485 link | | X485 | |
|----------------------|--------|------|---|
| | B | | 5 |
| Typically not in use | A | | 6 |
| | BGND | | 7 |
| | Shield | | 8 |

| Relay outputs | | XRO1...XRO3 | |
|--------------------|-----|-------------|----|
| Ready | NC | | 11 |
| 250 V AC / 30 V DC | COM | | 12 |
| 2 A | NO | | 13 |
| Running | NC | | 21 |
| 250 V AC / 30 V DC | COM | | 22 |
| 2 A | NO | | 23 |
| Faulted (-1) | NC | | 31 |
| 250 V AC / 30 V DC | COM | | 32 |
| 2 A | NO | | 33 |

| Safe torque off | | XSTO, XSTO OUT | |
|---|------|----------------|---|
| | OUT | | 1 |
| Safe torque off. Both circuits must be closed for the drive to start. The circuits are closed with jumper wires in the standard delivery. | SGND | | 2 |
| | IN1 | | 3 |
| | IN2 | | 4 |
| | IN1 | | 5 |
| | SGND | | 6 |
| Safe torque off output to inverter modules | IN2 | | 7 |
| | SGND | | 8 |

| Digital inputs | | XDI | |
|------------------------------------|------|-----|---|
| Stop (0) / Start (1) | DI1 | | 1 |
| Forward (0) / Reverse (1) | DI2 | | 2 |
| Reset | DI3 | | 3 |
| Acceleration & deceleration select | DI4 | | 4 |
| Constant speed 1 select (1 = on) | DI5 | | 5 |
| By default not in use | DI6 | | 6 |
| Run enable | DIIL | | 7 |

| Digital input/outputs | | XDIO | |
|-----------------------------|--------|------|---|
| Output: Ready | DIO1 | | 1 |
| Output: Running | DIO2 | | 2 |
| Digital input/output ground | DIOGND | | 3 |
| Digital input/output ground | DIOGND | | 4 |

| Auxiliary voltage output | | XD24 | |
|-------------------------------|----------------|------|---|
| +24 V DC 200 mA ¹⁾ | +24VD | | 5 |
| Digital input ground | DICOM | | 6 |
| +24 V DC 200 mA ¹⁾ | +24VD | | 7 |
| Digital input/output ground | DIOGND | | 8 |
| Ground selection switch | DICOM = DIOGND | | |

| Analog inputs, reference voltage output | | AI | |
|---|-------|----|---|
| 10 V DC, R_L 1...10 kohm | +VREF | | 1 |
| -10 V DC, R_L 1...10 kohm | -VREF | | 2 |
| Ground | AGND | | 3 |
| Speed reference | AI1+ | | 4 |
| 0(2)...10 V, R_{in} > 200 kohm | AI1+ | | 5 |
| By default not in use. | AI2+ | | 6 |
| 0(4)...20 mA, R_{in} = 100 ohm | AI2- | | 7 |

| Analog outputs | | AO | |
|--|------|----|---|
| Motor speed rpm 0...20 mA, R_L < 500 ohm | AO1 | | 1 |
| | AGND | | 2 |
| Motor current 0...20 mA, R_L < 500 ohm | AO2 | | 3 |
| | AGND | | 4 |

| External power input | | XPOW | |
|---|-------|------|---|
| | +24VI | | 1 |
| 24 V DC, 2.05 A | GND | | 2 |
| Two supplies can be connected for redundancy. | +24VI | | 3 |
| | GND | | 4 |

| Safety functions module connection | | X12 | |
|------------------------------------|--|-----|--|
| | | | |

| Control panel connection | | X13 | |
|--------------------------|--|-----|--|
| | | | |

| Memory unit connection | | | |
|------------------------|--|--|--|
| | | | |

¹⁾ Total load capacity of these outputs is 4.8 W (200 mA at 24 V) minus the power taken by DIO1 and DIO2.

Input/output, extension and feedback modules for increased connectivity



01



02 03



04



05



06



07



08



09



10



11



12



13



15



16



17



18

ACS380 ACS480

01 BAPO-01 Auxiliary power extension

External 24 V DC
The BAPO-01 auxiliary power extension module enables the use of an external auxiliary power supply with the drive. You need an external auxiliary power supply to keep the drive on during a power outage. Connect the auxiliary voltage supply to the +24V and DGND terminals on the drive.

02 BTAC-02 (+L535) Pulse encoder interface* (Only for ACS380)

HTL/TTL Encoder interface + External 24 V DC
The BTAC-02 module adds a digital pulse encoder interface to the drive. Use a pulse encoder if you need accurate speed or position (angle) feedback from the motor shaft. The BTAC module supplies power to the encoder. The BTAC module has the features of the BAPO-01 auxiliary power extension module. It provides back-up power to the drive.

03 BREL-01 Relay output extension* *External relay option (4xRO)* The BREL-01 relay output extension module adds four relay outputs to the drive.

04 BIO-01 (+L515) I/O extension module

3xDI, 1xAI, 1xDO
The BIO-01 front option module is to be used with fieldbus. The module is installed between the drive and the fieldbus module. BIO-01 terminal block is removable and uses spring clamps for assembly. Minimum software version 2.13



14



19

ACS580-01, -04, -07

05 CBAI-01 (+L500) Bipolar I/O adapter

Bipolar analog I/O adapter module
The CBAI-01 option includes two bipolar analog inputs and two unipolar outputs for bipolar voltage reference (from -10 V to +10 V). It also includes a switch can be used to select proper scaling of the analog output level.

06 CMOD-01 (+L501) Multifunction extension

External 24 V AC and DC 2xRO and 1xDO
The CMOD-01 module expands the outputs of the drive control unit. It has two relay outputs and one transistor output, which can function as a digital or frequency output. The extension module has an external power supply interface, which can be used to power up the drive control unit in case the drive power supply fails. If you do not need the back-up power supply, you do not have to connect it because the module is powered from the drive control board by default.**, ***)

07 CMOD-02 (+L523) Multifunction extension

External 24 V and isolated PTC interface
The CMOD-02 module has a motor thermistor connection for supervising the motor temperature and one relay output, which indicates the thermistor status. The extension module has an external power supply interface, which can be used to power up the drive control unit in case the drive power supply fails. If you do not need the back-up power supply, you do not have to connect it because the module is powered from the drive control board by default.**, ***)

08 CHDI-01 (+L512) Digital and relay extension

115/230 V digital input 6xDI and 2xRO
The CHDI-01 115/230 V digital input extension module expands the inputs of the drive control unit. It has six high voltage inputs and two relay outputs. ***)

09 CPTC-02 (+L537) ATEX certified PTC interface and external 24 V

The CPTC-02 ATEX-certified thermistor protection module, Ex II (2) GD module has a motor thermistor connection for supervising the motor temperature and one relay output, which indicates the thermistor status. To trip the drive, this overtemperature indication must be connected to the safe torque off (STO) input of the drive. (+L537 also requires the +Q971 option)

Note: The CPTC-02 module can be managed as a loose option and can also be retrofitted to the drive; in this case, to be compliant with regulations, the customer must ensure the following requirements:

- that the serial number of the drive/inverter module starts with 1, 4, 8, M or Y
- that the drive and option serial number is paired in a DIB (Drive Installed Base) portal
- that the included ATEX label for the SMT (Safe Motor Temperature function) is attached to the drive/inverter module to ensure the ATEX compliance of the safety circuit
- that the option module is installed in an option slot of the drive control unit and the applicable drive parameters are set
- that the PTC temperature sensors of the motor are connected to the PTC inputs of the option module.

For further information please contact local ABB.

*) The BTAC-02 and BREL-01 extensions look similar to each other, but they are two separate options.

**) External 24V input is standard in the control unit of drive modules. There is no need to have CMOD-01/-02 for external 24 V input.

***) L501, L523 and L512 are available as retro-fit options.

ACS880-01, -04, -07, -04F, -04FXT, 04XT, -11, -14, -17, -31, -34, -37

10 FEN-21 (+L516) Multifunction interface

2 inputs (Resolver, TTL pulse encoder), 1 output
The FEN-21 offers an interface for a resolver with PTC/KTY support and TTL encoder connection and a TTL encoder emulation output. It also supports two digital inputs for position latching.

11 FAIO-01 (+L525) Analog extension

2xAI(m/V), 2xAO(mA)
The FAIO-01 analog I/O extension module expands the analog inputs and outputs of the drive control unit. It has two bipolar/unipolar current/voltage inputs and two unipolar current outputs. FAIO-01 has basic insulation against the drive control unit ground, but together with basic-insulated motor temperature sensors, the FAIO-01 forms double insulation. This allows you to measure, for example, the motor winding temperature without a double or reinforced insulation requirement on the measuring element.

12 FIO-01 (+L501) Digital extension

4xDI/O, 2xRO
The FIO-01 is a general purpose digital input/output extension. It offers four bidirectional digital inputs/outputs and two electromechanical relays.

13 FIO-11 (+L500) Analog extension

3xAI (mA/V), 1xAO (mA), 2xDI/O
The FIO-11 is a general-purpose analog and digital input/output extension. It offers three analog inputs, one analog output and two digital inputs or outputs. All inputs and outputs are in the same potential and have a common isolation to control electronics.

14 FEA-03 (+L515) AIO and DIO extension and speed feedback interface

2xF-type option extension slots
The FEA-03 is an extension adapter that is used to install I/O extension modules and FEN encoder interface modules outside the drive unit. The FEA-03 extension adapter increases the number of F-series option modules that can be connected to the control unit of the drive. One or two option modules can be installed on one extension adapter. The extension adapter is connected to the drive via a fiber-optic link using the DDCS protocol.

15 FPFC-01 (+L536) FPFC-01 thermistor protection module

The FPFC-01 module implements the safe motor temperature (SMT) safety function as defined in EN/IEC 61800-5-2. Inside the module, there is reinforced insulation between the motor thermistor connection and the other terminals of the module. The insulation forms a reliable protective separation between the motor main circuit and the drive control circuits. Therefore, the drive control board is PELV compatible also when the FPFC-01 module and a thermistor protection circuit are installed. To implement the Safe motor temperature (SMT) function, you can connect the FPFC-01 module directly to the drive Safe torque off (STO) circuit, or you can use it together with an FSO module. The FPFC-01 module is suitable for safety-related over temperature protection functions when ATEX certification is not needed.

16 FPFC-02 (+L537) ATEX-certified thermistor protection

The FPFC-02 ATEX-certified thermistor protection module, Ex II (2) GD is type-examined as a protective device within the scope of the European ATEX Product Directive. This enables the use of the module in temperature protection of motors in explosive atmospheres (Ex motors). Inside the module, there is reinforced insulation between the motor thermistor connection and the other terminals of the module. The insulation forms a reliable protective separation between the motor main circuit and the drive control circuits. To implement the ATEX-certified thermistor protection function, you can connect the FPFC-02 module directly to the drive Safe torque off (STO) circuit, or you can use it together with an FSO module.

17 FEN-01 (+L517) TTL encoder interface

2 inputs (TTL pulse encoder), 1 output
The FEN-01 offers an interface for two TTL encoder connections, one with commutation signals and PTC support. It also offers a TTL encoder output for emulation purposes and two digital latch inputs for position latching.

18 FEN-11 (+L518) Absolute encoder interface

2 inputs (SinCos absolute, TTL pulse encoder), 1 output
The FEN-11 offers an interface for an absolute encoder with PTC/KTY support and TTL encoder connection and a TTL encoder emulation output. It also supports two digital inputs for position latching.

19 FEN-31 (+L502) HTL pulse encoder interface

1 input (HTL pulse encoder), 1 output
The FEN-31 is an interface between the control board and an HTL encoder. It supports various types of HTL encoders. A PTC or KTY temperature sensor can be attached to one of the connections of the FEN-31 interface. The FEN-31 offers an RS-422-standard-compliant TTL encoder emulation output and two digital inputs. It also includes cable fault diagnostics for some HTL encoder types. See the drive firmware manual for details.

Ordering information

How do I build an ordering code

The type designation tells you the specifications and configuration of the drive.
The table shows the primary drive variants.

Sample type code: ACS380-042S-02A6-4

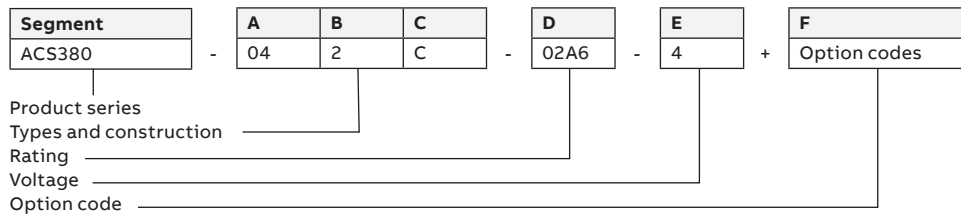

Sample type code: ACS580-01-293A-4+XXXX

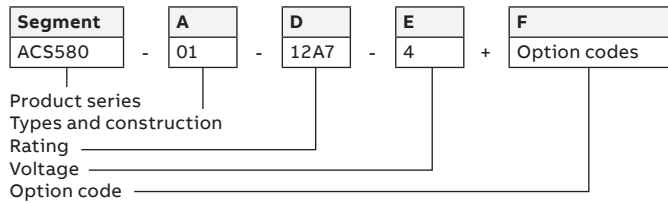

| Basic codes | | | |
|-------------|----------------|---|---|
| Segment | Option | Drive | Description |
| A | Construction | ACS380 | 04 = Module, IP20 |
| | | ACS480 | 04 = Wall mounted, IP20 (UL Type 1), assistant control panel with a USB port, EMC C2 filter (internal EMC filter), safe torque off, braking chopper, coated boards, quick installation and start-up guide. |
| | | ACS580 | 01 = When no options are selected: Wall mounted, IP21 (UL Type 1), assistant control panel with a USB port, choke, EMC C2 filter (internal EMC filter), safe torque off, braking chopper in frames R1, R2, R3, coated boards, cable lead through entry from the bottom, cable box or the conduit plate with cable entries, quick installation and start-up guide multilingual). |
| | | | 04 = Drive with coated circuit boards, integrated control unit (inside drive module), control panel door mounting kit, embedded Modbus RTU adapter, EIA-485 (standard), assistant control panel with USB-port, quick guides with default set of languages, web links to basic PC tool and manuals in quick guide. |
| | | | 07 = Cabinet-built, IP21, Main switch and aR fuses, Assistant control panel (ACS-AP-S), EMC filter C2 (R6-R9)/ C3 (R10-R11), Common mode filter (R10-R11), ACS580 standard control program, Safe torque-off, Boards with coating, Bottom entry and exit of cables, Cable lead through entry, One set of default electric documents in USB stick. |
| | | ACS880 | 01 = Wall-mounted, IP21 (UL type 1), Bluetooth assistant control panel, Inbuild choke, No EMC filter, Primary control program, Safe torque-off, Cable lead through entry, Braking chopper in frame sizes R1, R2, R3 and R4, Boards with coating, Quick guides with default set of languages. |
| | | | 04 = Module to be installed in an enclosure, IP20 (UL open type) as standard, bookshelf mounting with pedestal, external control unit, Bluetooth assistant control panel and control panel holder, inbuild choke, including full size output terminals, no EMC filter, no DC connection busbars, Primary control program, Safe torque off, Boards with coating, Quick guides. |
| | | | 04F = Flange mounted module to be installed in an enclosure, front side IP20 (UL Open Type), back side IP55 (UL Type 12) as standard, flat mounting, no pedestal, external control unit, control panel with Bluetooth communication possibility and control panel holder, inbuild choke, including full size output terminals, no EMC filter, no DC connection busbars, Primary control program, Safe torque off, Boards with coating, Quick guides. |
| | | | 04XT = two drive modules 2xR10 or 2xR11, to be installed in an enclosure, IP00 (UL open type), bookshelf mounting with pedestal, external BCU-02 control unit, 3 m cables for connecting the control unit to the drive module, inbuild choke, terminals for input and motor and DC connection, no EMC filter, common mode filter (+E208), one ramp, Primary control program, Safe torque off, Boards with coating, memory stick including all manuals with all available languages. |
| | | | 04FXT = two flange mounted drive modules R11, to be installed in an enclosure, Front: IP00 (UL open type), Heatsink: IP55 (UL Type 12), flat mounting, no pedestal, external BCU-02 control unit, 3 m cables for connecting the control unit to the drive module, build-in input choke, terminals for input and motor and DC connection, no EMC filter, common mode filter (+E208), Primary control program, Safe torque off, Boards with coating, memory stick including all manuals with all available languages. |
| | | | 07 = Cabinet-built, IP22 (UL type1), Main switch and aR fuses, Bluetooth assistant control panel, Built-in DC (R6-R9) or AC (R10, R11) choke, No EMC filter, Primary control program, Safe torque-off, Boards with coating, Bottom entry and exit of cables, Cable lead through entry, One set of default electric documents in USB stick, warranty 24 months from delivery. |
| | | | 11 = Regenerative Wall-mounted, IP21 (UL type 1). |
| | | | 14 = Regenerative module to be installed in an enclosure, IP20 (UL open type) as standard. |
| | | | 17 = Cabinet-built regenerative, IP22 (UL type1), Main switch and aR fuses, Main contactor, Bluetooth assistant control panel, EMC/RFI filter Cat.3 2 nd Env in R11 TN (grounded) systems (no C3 filter for R8), Primary control program, Safe torque-off, Boards with coating, Bottom entry and exit of cables, Cable lead through entry, One set of default electric documents in USB stick. |
| | | | 31 = Low-harmonic Wall-mounted, IP21 (UL type 1). Bluetooth assistant control panel, No EMC filter, Primary control program, Safe torque-off, Cable lead through entry, Boards with coating, Quick guides with default set of languages. |
| | | 34 = Low-harmonic module to be installed in an enclosure, IP20 (UL open type) as standard. Bookshelf mounting with pedestal, external control unit, Bluetooth assistant control panel and control panel cable, inbuild LCL filter, including full size output terminals, no EMC filter, DC connection busbars, Primary control program, Safe torque off, Boards with coating, Quick guides. | |
| | | 37 = Cabinet-built low harmonic, IP22 (UL type1), Main switch and aR fuses, Main contactor, Bluetooth assistant control panel, EMC/RFI filter Cat.3 2 nd Env in R11 TN (grounded) systems (no C3 filter for R8), Primary control program, Safe torque-off, Boards with coating, Bottom entry and exit of cables, Cable lead through entry, One set of default electric documents in USB stick. | |
| B | EMC filter | Only for ACS380-04 | 0 = C3 (3-phase 400 V) or C4 (1-phase 230 V) 2 = C2 (3-phase 400 V, 1-phase 230 V) |
| C | Connectivity | Only for ACS380-04 | S = Standard variant (I/O and Modbus), C = Configured variant |
| D | Current rating | For all | Refer to the rating table |

| Basic codes | | | | | | | | |
|--|-------------------------|---|---|--|--|-----------|-----------|-----------|
| Segment | Option | Code | Description | ACS380-04 | ACS480-04 | ACS580-01 | ACS580-04 | ACS580-07 |
| E | Voltage rating | | 1 = 1-phase, 230 V | ● | - | - | - | - |
| | | | 2 = 3-phase, 208...240 V | - | - | ● | - | - |
| | | | 3 = 3-phase, 380...415 V | - | - | - | - | - |
| | | | 4 = 3-phase, 380...480 V | ● | ● | ● | ● | ● |
| | | | 5 = 380...500 V | - | - | - | - | - |
| | | | 7 = 525...690 V | - | - | - | - | - |
| | | | Option codes | | 3/4 slots available for I/O options, fieldbus adapters and safety option | - | - | - |
| | | | 1 can be used for fieldbus adapter or I/O & Modbus module | ● | - | - | - | - |
| | | | 1 slot available for I/O options, 1 slot available for fieldbus | - | ● | ● | ● | ● |
| F | Control programs | +N5000 | Winder control program | - | - | - | - | - |
| | | +N5050 | Crane control program | - | - | - | - | - |
| | | +N5100 | Winch control program | - | - | - | - | - |
| | | +N5150 | Centrifuge | - | - | - | - | - |
| | | +N5200 | PCP control program | - | - | - | - | - |
| | | +N5250 | Rod pump control program | - | - | - | - | - |
| | | +N5300 | Test bench control program | - | - | - | - | - |
| | | +N5350 | Cooling Tower control program | - | - | - | - | - |
| | | +N5450 | Override control program | - | - | - | - | - |
| | | +N5500 | Spinning and traverse control program | - | - | - | - | - |
| | | +N5600 | ESP control program | - | - | - | - | - |
| | | +N5650 | Tower crane control program | - | - | - | - | - |
| | | +N5700 | Position control program (limited availability) | - | - | - | - | - |
| | | +N7502 | Primary control program SynRM | - | - | - | - | - |
| | | +N5900 | Anti-cavitation control program | - | - | - | - | - |
| | | Programmability | +N8010 | Drive application programming (IEC 61131-3 programming) Note: +N8010 is not available together with Winder, Crane or Winch control programs | - | - | - | - |
| Primary control program, variants | +N7502 | SynRM control firmware (Delivered always with the latest version) | - | - | - | - | - | |

● = Available (standard, with plus code or ordering code)

| Basic codes | | | | | | | | | | | | | |
|--|-------------------------|--|---|--|-----------|------------|--------------|-------------|-----------|--------------|--------------|--------------|---|
| Segment | Option | Code | Description | ACS880-01 | ACS880-04 | ACS880-04F | ACS880-04FXT | ACS880-04XT | ACS880-07 | ACS880-11/31 | ACS880-14/34 | ACS880-17/37 | |
| E | Voltage rating | | 1 = 1-phase, 230 V | - | - | - | - | - | - | - | - | - | |
| | | | 2 = 3-phase, 208...240 V | ● | - | - | - | - | - | - | - | - | - |
| | | | 3 = 3-phase, 380...415 V | ● | ● | ● | ● | ● | ● | ● | ● | ● | ● |
| | | | 4 = 3-phase, 380...480 V | ● | - | - | - | - | - | - | - | - | - |
| | | | 5 = 380...500 V | ● | ● | ● | ● | ● | ● | ● | ● | ● | ● |
| | | | 7 = 525...690 V | ● | ● | ● | ● | ● | ● | ● | - | ● | ● |
| | | Option codes | | 3/4 slots available for I/O options, fieldbus adapters and safety option | ● | ● | ● | ● | ● | ● | ● | ● | ● |
| | | | 1 can be used for fieldbus adapter or I/O & Modbus module | - | - | - | - | - | - | - | - | - | |
| | | | 1 slot available for I/O options, 1 slot available for fieldbus | - | - | - | - | - | - | - | - | - | |
| F | Control programs | +N5000 | Winder control program | ● | ● | ● | ● | ● | ● | ● | ● | ● | |
| | | +N5050 | Crane control program | ● | ● | ● | ● | ● | ● | ● | ● | ● | |
| | | +N5100 | Winch control program | ● | ● | ● | ● | ● | ● | ● | ● | ● | |
| | | +N5150 | Centrifuge | ● | ● | ● | - | - | - | ● | ● | ● | |
| | | +N5200 | PCP control program | ● | ● | ● | ● | ● | ● | ● | ● | ● | |
| | | +N5250 | Rod pump control program | ● | ● | ● | - | - | - | ● | ● | - | |
| | | +N5300 | Test bench control program | - | - | ● | ● | ● | ● | ● | ● | ● | |
| | | +N5350 | Cooling Tower control program | ● | ● | ● | - | - | - | ● | ● | ● | |
| | | +N5450 | Override control program | ● | ● | ● | ● | ● | ● | - | - | - | |
| | | +N5500 | Spinning and traverse control program | ● | ● | ● | - | - | - | - | - | ● | |
| | | +N5600 | ESP control program | ● | ● | ● | ● | ● | ● | ● | ● | ● | |
| | | +N5650 | Tower crane control program | ● | ● | ● | - | - | - | ● | ● | - | |
| | | +N5700 | Position control program (limited availability) | - | - | - | ● | ● | ● | - | - | ● | |
| | | +N7502 | Primary control program SynRM | ● | ● | ● | - | - | ● | ● | ● | ● | |
| | +N5900 | Anti-cavitation control program | ● | ● | ● | - | - | - | ● | ● | - | | |
| Programmability | +N8010 | Drive application programming (IEC 61131-3 programming) Note: +N8010 is not available together with Winder, Crane or Winch control programs | ● | ● | ● | ● | ● | ● | ● | ● | ● | | |
| Primary control program, variants | +N7502 | SynRM control firmware (Delivered always with the latest version) | ● | ● | - | - | - | ● | - | - | ● | | |

● = Available (standard, with plus code or ordering code)

Basic codes

| Segment | Option | Code | Description | | | | | |
|----------|--|---|---|-----------|-----------|-----------|-----------|-----------|
| | | | | ACS380-04 | ACS480-04 | ACS580-01 | ACS580-04 | ACS580-07 |
| F | I/O extensions and feedback interfaces | +L500 | FIO-11 analog I/O extension module | - | - | ● | ● | - |
| | | +L501 | FIO-01 digital I/O extension module | - | - | ● | ● | ● |
| | | +L502 | FEN-31 HTL incremental encoder interface module | - | - | - | - | - |
| | | +L503 | FDCO-01 optical DDCS communication adapter module | - | - | - | - | - |
| | | +L504 | Additional I/O-Terminal Block | - | - | - | - | ● |
| | | +L505 | Thermistor relay (non Ex i compatible, 1 or 2 pcs) | - | - | - | - | - |
| | | +L506 | Pt100 relay (non Ex i compatible, 2, 3 or 5 pcs) | - | - | - | - | ● |
| | | +L508 | FDCO-02 optical DDCS communication adapter module | - | - | - | - | - |
| | | +L511 | BREL-01 External relay option (4 x relay) (side option) | ● | ● | - | - | - |
| | | +L512 | CHDI-01 115/230 V Digital input extension (6×DI and 2×RO) | - | - | ● | ● | ● |
| | | +L513 | ATEX Certified motor thermal protection with thermistor relay (non Ex i compatible, 1 or 2 pcs) | - | - | - | - | - |
| | | +L514 | Ex i compatible ATEX Certified motor thermal protection with Pt100 relay (3 or 5 pcs) | - | - | - | - | - |
| | | +L515 | BIO-01 I/O option module (front option, can be used together with fieldbus) | ● | ● | - | - | - |
| | | +L516 | FEN-21 resolver interface module | - | - | - | - | - |
| | | +L517 | FEN-01 TTL incremental encoder interface module | - | - | - | - | - |
| | | +L518 | FEN-11 absolute encoder interface module | - | - | - | - | - |
| | | +L521 | FSE-31 pulse encoder interface module | - | - | - | - | - |
| | | +L523 | CMOD-02 External 24 V AC/DC and isolated PTC interface | - | - | ● | ● | ● |
| | | +L525 | FAIO-01 analog I/O extension module | - | - | - | - | - |
| | | +L526 | FDIO-01 digital I/O extension module | - | - | - | - | - |
| | | +L534 | BAPO-01 External 24 V DC (side option) | ● | ● | - | - | - |
| | | +L535 | BTAC-02 HTL/TTL encoder interface + External 24 V DC (side option) | ● | - | - | - | - |
| | | +L536 | FPTC-01 Thermistor protection module for ACS880 drives | - | - | - | - | - |
| | +L537 | CPTC-02 ATEX-certified thermistor protection module, EX II (2) GD for ACS580 drives | - | - | ● | ● | ● | |
| | +L538 | BMIO-01 I/O & Modbus option module (front option) | ● | - | - | - | - | |
| | +L540 | RIO-01 Standard I/O & Modbus RTU module (standard) | - | ● | - | - | - | |
| | +OL540 | Remove the standard I/O module RIO-01 | - | ● | - | - | - | |
| | Fieldbus interfaces | +K451 | DeviceNet™ (FDNA-01) | ● | ● | ● | ● | ● |
| | | +K454 | PROFIBUS® DP (FPBA-01) | ● | ● | ● | ● | ● |
| | | +K457 | CANopen® (FCAN-01) | ● | ● | ● | ● | ● |
| | | +K458 | RS-485 (FSCA-01) | - | - | ● | ● | ● |
| | | +K462 | ControlNet™ (FCNA-01) | ● | ● | ● | ● | ● |
| | | +K469 | EtherCAT® (FECA-01) | ● | ● | ● | ● | ● |
| | | +K470 | Ethernet POWERLINK (FEPL-01) | ● | ● | ● | ● | ● |
| | | +K490 | EtherNet/IP™ (FEIP-21) | ● | ● | ● | ● | ● |
| | | +K491 | Modbus®/TCP (FMBT-21) | ● | ● | ● | ● | ● |
| | | +K492 | PROFINET® IO (FPNO-21) | ● | ● | ● | ● | - |
| | | +K495 | CANopen (screw terminals) (BCAN-11) | ● | - | - | - | - |
| | +Q986 | FSPS-21 Safety function module with integrated ProfiSafe | ● | - | ● | ● | ● | |
| | ABB Ability™ Conditon Monitoring for drives | +K496 | Neta-21 Wired remote monitoring system | - | - | - | - | ● |
| | | +K497 | Option with Wireless modem for wireless connectivity | - | - | - | - | ● |
| | Embedded fieldbus | +CEIA-01 | Embedded Modbus RTU adapter | - | - | ● | - | - |
| | | +EIA-485 | Embedded Modbus RTU adapter (as standard) | - | ● | ● | - | - |

● = Available (standard, with plus code or ordering code)

| Basic codes | | | | | | | | | | | | |
|-------------|--|----------|---|-----------|---|------------|------------------------------------|-------------|-----------|--------------|--------------|--------------|
| Segment | Option | Code | Description | ACS880-01 | ACS880-04 | ACS880-04F | ACS880-04FXT | ACS880-04XT | ACS880-07 | ACS880-11/31 | ACS880-14/34 | ACS880-17/37 |
| | | | | F | I/O extensions and feedback interfaces | +L500 | FIO-11 analog I/O extension module | ● | ● | ● | ● | ● |
| | | +L501 | FIO-01 digital I/O extension module | ● | ● | ● | ● | ● | ● | ● | ● | ● |
| | | +L502 | FEN-31 HTL incremental encoder interface module | ● | ● | ● | ● | ● | ● | ● | ● | ● |
| | | +L503 | FDCO-01 optical DDCS communication adapter module | ● | ● | ● | ● | ● | ● | ● | ● | ● |
| | | +L504 | Additional I/O-Terminal Block | - | - | - | - | - | ● | - | - | ● |
| | | +L505 | Thermistor relay (non Ex i compatible, 1 or 2 pcs) | - | - | - | - | - | ● | - | - | ● |
| | | +L506 | Pt100 relay (non Ex i compatible, 2, 3 or 5 pcs) | - | - | - | - | - | ● | - | - | ● |
| | | +L508 | FDCO-02 optical DDCS communication adapter module | ● | ● | ● | ● | ● | ● | ● | ● | ● |
| | | +L511 | BREL-01 External relay option (4 x relay) (side option) | - | - | - | - | - | - | - | - | - |
| | | +L512 | CHDI-01 115/230 V Digital input extension (6×DI and 2×RO) | - | - | - | - | - | - | - | - | - |
| | | +L513 | ATEX Certified motor thermal protection with thermistor relay (non Ex i compatible, 1 or 2 pcs) | - | - | - | - | - | ● | - | - | ● |
| | | +L514 | Ex i compatible ATEX Certified motor thermal protection with Pt100 relay (3 or 5 pcs) | - | - | - | - | - | ● | - | - | ● |
| | | +L515 | BIO-01 I/O option module (front option, can be used together with fieldbus) | - | ● | - | - | ● | ● | - | ● | ● |
| | | +L516 | FEN-21 resolver interface module | ● | ● | ● | ● | ● | ● | ● | ● | ● |
| | | +L517 | FEN-01 TTL incremental encoder interface module | ● | ● | ● | ● | ● | ● | ● | ● | ● |
| | | +L518 | FEN-11 absolute encoder interface module | ● | ● | ● | ● | ● | ● | ● | ● | ● |
| | | +L521 | FSE-31 pulse encoder interface module | ● | ● | ● | ● | ● | ● | ● | ● | ● |
| | | +L523 | CMOD-02 External 24 V AC/DC and isolated PTC interface | - | - | - | - | - | - | - | - | - |
| | | +L525 | FAIO-01 analog I/O extension module | ● | ● | ● | ● | ● | ● | ● | ● | ● |
| | | +L526 | FDIO-01 digital I/O extension module | ● | ● | ● | ● | ● | ● | ● | ● | ● |
| | | +L534 | BAPO-01 External 24 V DC (side option) | - | - | - | - | - | - | - | - | - |
| | | +L535 | BTAC-02 HTL/TTL encoder interface + External 24 V DC (side option) | - | - | - | - | - | - | - | - | - |
| | | +L536 | FPTC-01 Thermistor protection module for ACS880 drives | ● | ● | ● | ● | ● | ● | ● | ● | ● |
| | | +L537 | FPTC-02 ATEX-certified thermistor protection module, EX II (2) GD for ACS880 drives | ● | ● | ● | ● | ● | ● | ● | ● | ● |
| | | +L538 | BMIO-01 I/O & Modbus option module (front option) | - | - | - | - | - | - | - | - | - |
| | | +L540 | RIIO-01 Standard I/O & Modbus RTU module (standard) | - | - | - | - | - | - | - | - | - |
| | | +OL540 | | - | - | - | - | - | - | - | - | - |
| | Fieldbus interfaces | +K451 | DeviceNet™ (FDNA-01) | ● | ● | ● | ● | ● | ● | ● | ● | ● |
| | | +K454 | PROFIBUS® DP (FPBA-01) | ● | ● | ● | ● | ● | ● | ● | ● | ● |
| | | +K457 | CANopen® (FCAN-01) | ● | ● | ● | ● | ● | ● | ● | ● | ● |
| | | +K458 | RS-485 (FSCA-01) | ● | ● | ● | ● | ● | ● | ● | ● | ● |
| | | +K462 | ControlNet™ (FCNA-01) | ● | ● | ● | ● | ● | ● | ● | ● | ● |
| | | +K469 | EtherCAT® (FECA-01) | ● | ● | ● | ● | ● | ● | ● | ● | ● |
| | | +K470 | Ethernet POWERLINK (FEPL-01) | ● | ● | ● | ● | ● | ● | ● | ● | ● |
| | | +K490 | EtherNet/IP™ (FEIP-21) | ● | ● | ● | ● | ● | ● | ● | ● | ● |
| | | +K491 | Modbus®/TCP (FMBT-21) | ● | ● | ● | ● | ● | ● | ● | ● | ● |
| | | +K492 | PROFINET® IO (FPNO-21) | ● | ● | ● | ● | ● | ● | ● | ● | ● |
| | | +K495 | CANopen (screw terminals) (BCAN-11) | - | - | - | - | - | - | - | - | - |
| | | +Q986 | FSPS-21 Safety function module with integrated ProfiSafe | ● | ● | ● | ● | ● | ● | ● | ● | ● |
| | ABB Ability™ Condon Monitoring for drives | +K496 | Neta-21 Wired remote monitoring system | - | - | - | - | - | ● | - | - | ● |
| | | +K497 | Option with Wireless modem for wireless connectivity | - | - | - | - | - | ● | - | - | ● |
| | Embedded fieldbus | +CEIA-01 | Embedded Modbus RTU adapter | - | - | - | - | - | - | - | - | - |
| | | +EIA-485 | Embedded Modbus RTU adapter (as standard) | - | - | - | - | - | - | - | - | - |

● = Available (standard, with plus code or ordering code)

| Basic codes | | | | | | | | |
|-------------|--|---|--|-----------|-----------|-----------|-----------|-----------|
| Segment | Option | Code | Description | ACS380-04 | ACS480-04 | ACS580-01 | ACS580-04 | ACS580-07 |
| F | Safety Functions | +Q950 | Prevention of unexpected start up with FSO | - | - | - | - | - |
| | | +Q951 | Emergency Stop, Category 0 with opening main contactor/breaker | - | - | - | - | ● |
| | | +Q952 | Emergency Stop, Category 1 with opening main contactor/breaker | - | - | - | - | - |
| | | +Q954 | Earth Fault Monitoring, Unearthed Mains | - | - | - | - | - |
| | | +Q957 | Prevention of unexpected start up with safety relay | - | - | - | - | - |
| | | +Q963 | Emergency Stop, Category 0 without opening main contactor with safety relay | - | - | - | - | ● |
| | | +Q964 | SS1, Emergency Stop, Category 1 without opening main contactor/breaker with safety relay | - | - | - | - | - |
| | | +Q965 | Safely limited speed with encoder | - | - | - | - | - |
| | | +Q971 | ATEX-certified Safe motor disconnection function using the Safe torque off function (Only with +L537) | - | - | ● | ● | ● |
| | | +Q972 | FSO-21 safety functions module | - | - | - | - | - |
| | | +Q973 | FSO-12 safety functions module | - | - | - | - | - |
| | | +Q978 | Emergency Stop with main contactor/breaker, configurable category 0 or 1 | - | - | - | - | - |
| | | +Q979 | Emergency Stop with STO, configurable category 0 or 1 | - | - | - | - | - |
| | | +Q982 | PROFIsafe safety communication | - | - | - | - | - |
| | | +P947 | Safety data calculation for tailored safety functions | - | - | - | - | - |
| | Protection class | +B051 | IP20 Finger safe | - | - | - | ● | - |
| | | +B054 | IP42 (UL type 1) | - | - | - | - | ● |
| | | +B055 | IP54 (UL type 12) | - | - | - | - | ● |
| | | +B056 | IP55 (UL type 12) | - | - | ● | - | - |
| | | +C128 | Air inlet through bottom, requires B055, no input air filter, max ambient 40 °C | - | - | - | - | - |
| | | +C130 | Channeled air outlet | - | - | - | - | - |
| | Control panel and control units | +OJ400 | No control panel. Includes control panel holder cover. Note: You need at least one loose control panel to be able to commission the drive. | - | ● | ● | ● | - |
| | | +OJ427 | No control panel holder and no control panel | - | - | - | - | - |
| | | +J400 | ACS-AP-S Assistant control panel (as standard) | ● | ● | ● | - | - |
| | | +J404 | ACS-BP-S Basic control panel | ● | ● | ● | ● | - |
| | | +J410 | Control panel door mounting kit (includes DPMP-03 / has to be included into the standard delivery) | - | ● | - | - | - |
| | | +J413 | DPMP-02 door mounting kit (surface mounting) for the panel | ● | ● | ● | - | - |
| | | +J414 | Control panel holder integrated in the unit | - | - | - | - | - |
| | | +J424 | CDUM-01 Blank control panel cover (no control panel delivered) | - | ● | ● | ● | ● |
| | | +J425 | ACS-AP-I Assistant control panel | ● | ● | ● | ● | - |
| | | +J429 | ACS-AP-W Assistant control panel with a bluetooth interface | ● | ● | ● | ● | ● |
| | | +J431 | USB to RJ-45 cable that is used together with RDUM-01 for PC connection | - | ● | - | - | - |
| | | +P905 | Integrated control unit (inside drive module) | ● | ● | - | - | - |
| | | +V993 | ZCU-11 control unit | - | - | - | - | - |
| | Filters | +E200 | EMC filter for second environment TN (grounded) system, category C3 | - | - | - | - | - |
| | | +E201 | EMC filter for second environment IT (ungrounded) system, category C3 | - | - | - | - | - |
| | | +E202 | EMC filter for first environment TN (grounded) system, category C2 | - | - | - | - | - |
| | | +E205 | Du/dt limitation by choke | - | - | - | - | ● |
| | | +E206 | Sine output filter | - | - | - | - | - |
| | | +E208 | Common mode filter | - | ● | - | - | ● |
| | | +E210 | EMC/RFI-filter, C3, 2 nd Environment, Unrestricted (Earthed & Unearthed Networks) (this option has to be included into the standard delivery) | - | ● | - | - | - |
| | | +E223 | EMC filter, category C1 for earthed network (R1-R5) | - | - | ● | - | - |
| +F316 | | Main switch and EMC filter, category C1 for earthed network (R1-R5) | - | - | ● | - | - | |

● = Available (standard, with plus code or ordering code)

| Basic codes | | | | | | | | | | | | | |
|--|-------------------------|--|--|-----------|-----------|------------|--------------|-------------|-----------|--------------|--------------|--------------|---|
| Segment | Option | Code | Description | ACS880-01 | ACS880-04 | ACS880-04F | ACS880-04FXT | ACS880-04XT | ACS880-07 | ACS880-11/31 | ACS880-14/34 | ACS880-17/37 | |
| F | Safety Functions | +Q950 | Prevention of unexpected start up with FSO | - | - | - | - | - | ● | - | - | ● | |
| | | +Q951 | Emergency Stop, Category 0 with opening main contactor/breaker | - | - | - | - | - | ● | - | - | ● | |
| | | +Q952 | Emergency Stop, Category 1 with opening main contactor/breaker | - | - | - | - | - | ● | - | - | ● | |
| | | +Q954 | Earth Fault Monitoring, Unearthed Mains | - | - | - | - | - | ● | - | - | ● | |
| | | +Q957 | Prevention of unexpected start up with safety relay | - | - | - | - | - | ● | - | - | ● | |
| | | +Q963 | Emergency Stop, Category 0 without opening main contactor with safety relay | - | - | - | - | - | ● | - | - | ● | |
| | | +Q964 | SS1, Emergency Stop, Category 1 without opening main contactor/breaker with safety relay | - | - | - | - | - | ● | - | - | ● | |
| | | +Q965 | Safely limited speed with encoder | - | - | - | - | - | ● | - | - | ● | |
| | | +Q971 | ATEX-certified Safe motor disconnection function using the Safe torque off function | ● | ● | ● | ● | ● | ● | ● | ● | ● | ● |
| | | +Q972 | FSO-21 safety functions module | ● | ● | ● | ● | ● | ● | ● | ● | ● | ● |
| | | +Q973 | FSO-12 safety functions module | ● | ● | ● | ● | ● | ● | ● | ● | ● | ● |
| | | +Q978 | Emergency Stop with main contactor/breaker, configurable category 0 or 1 | - | - | - | - | - | ● | - | - | ● | |
| | | +Q979 | Emergency Stop with STO, configurable category 0 or 1 | - | - | - | - | - | ● | - | - | ● | |
| | | +Q982 | PROFIsafe safety communication | ● | ● | - | - | ● | ● | ● | ● | ● | ● |
| | | +P947 | Safety data calculation for tailored safety functions | - | - | - | - | - | ● | - | - | - | ● |
| Protection class | +B051 | IP20 Finger safe | - | - | - | - | - | - | - | - | - | - | |
| | +B054 | IP42 (UL type 1) | - | - | - | - | - | ● | - | - | ● | - | |
| | +B055 | IP54 (UL type 12) | - | - | - | - | - | ● | - | - | ● | - | |
| | +B056 | IP55 (UL type 12) | ● | - | - | - | - | - | ● | - | - | - | |
| | +C128 | Air inlet through bottom, requires B055, no input air filter, max ambient 40 °C | - | - | - | - | - | - | ● | - | - | ● | |
| | +C130 | Channeled air outlet | - | - | - | - | - | ● | - | - | - | ● | |
| Control panel and control units | +OJ400 | No control panel. Includes control panel holder cover. Note: You need at least one loose control panel to be able to commission the drive. | ● | ● | ● | - | - | - | - | ● | ● | - | |
| | +OJ427 | No control panel holder and no control panel | - | - | - | - | - | - | - | - | - | - | |
| | +J400 | ACS-AP-S Assistant control panel (as standard) | - | - | - | - | - | - | - | - | - | - | |
| | +J404 | ACS-BP-S Basic control panel | - | - | - | - | - | - | - | - | - | - | |
| | +J410 | Control panel door mounting kit (includes DPMP-03 / has to be included into the standard delivery) | - | ● | ● | - | - | - | - | - | ● | - | |
| | +J413 | DPMP-02 door mounting kit (surface mounting) for the panel | - | ● | ● | - | - | - | - | - | ● | - | |
| | +J414 | Control panel holder integrated in the unit | - | ● | - | - | - | - | - | - | - | - | |
| | +J424 | CDUM-01 Blank control panel cover (no control panel delivered) | - | - | - | - | - | - | - | - | - | - | |
| | +J425 | ACS-AP-I Assistant control panel | ● | ● | ● | - | - | ● | ● | ● | ● | ● | |
| | +J429 | ACS-AP-W Assistant control panel with a bluetooth interface | ● | ● | ● | ● | ● | ● | ● | ● | ● | ● | |
| | +J431 | USB to RJ-45 cable that is used together with RDUM-01 for PC connection | - | - | - | - | - | - | - | - | - | - | |
| | +P905 | Integrated control unit (inside drive module) | - | ● | - | - | - | - | - | - | - | - | |
| +V993 | ZCU-11 control unit | ● | - | - | - | - | - | - | - | - | - | | |
| Filters | +E200 | EMC filter for second environment TN (grounded) system, category C3 | ● | ● | ● | ● | ● | ● | ● | ● | - | ● | |
| | +E201 | EMC filter for second environment IT (ungrounded) system, category C3 | ● | ● | ● | ● | ● | ● | ● | ● | - | ● | |
| | +E202 | EMC filter for first environment TN (grounded) system, category C2 | ● | ● | ● | ● | ● | ● | ● | ● | ● | ● | |
| | +E205 | Du/dt limitation by choke | - | - | - | - | - | ● | - | - | - | ● | |
| | +E206 | Sine output filter | - | - | - | - | - | ● | - | - | - | ● | |
| | +E208 | Common mode filter | ● | ● | ● | ● | ● | ● | ● | ● | ● | ● | |
| | +E210 | EMC/RFI-filter, C3, 2 nd Environment, Unrestricted (Earthed & Unearthed Networks) (this option has to be included into the standard delivery) | - | - | - | - | - | - | - | - | ● | - | |
| | +E223 | EMC filter, category C1 for earthed network (R1-R5) | - | - | - | - | - | - | - | - | - | - | |
| | +F316 | Main switch and EMC filter, category C1 for earthed network (R1-R5) | - | - | - | - | - | - | - | - | - | - | |

● = Available (standard, with plus code or ordering code)

| Basic codes | | | | | | | | |
|-------------|-----------------------------|------------------------------|---|-----------|-----------|-----------|-----------|-----------|
| Segment | Option | Code | Description | ACS380-04 | ACS480-04 | ACS580-01 | ACS580-04 | ACS580-07 |
| F | Resistor braking | +D150 | Braking chopper | - | ● | - | - | - |
| | | +D151 | Braking resistor | - | - | - | - | - |
| | Line options | +F250 | Line contactor | - | - | - | - | ● |
| | | +F277 | Flange mounted switch for MCCB (Manufactured in US only) | - | - | - | - | - |
| | | +F278 | Main switch disconnecter (R1-R5) | - | - | ● | - | - |
| | | +F289 | Main case circuit breaker (UL listed, requires C129 option) | - | - | - | - | - |
| | Construction | +C121 | Marine construction | - | - | - | - | - |
| | | +C129 | Cabinet drive is UL listed | - | - | - | - | ● |
| | | +C134 | CSA approved | - | - | - | - | - |
| | | +C180 | Seismic design | - | - | - | - | - |
| | | +C164 | Plinth height 100 mm | - | - | - | - | ● |
| | | +C179 | Plinth height 200 mm | - | - | - | - | ● |
| | | +C180 | Seismic design (Seismic capability according to International building code 2012, test procedure ICC-ES AC-156. Installation level 100% of the building height and SDS ≤ 2.0 g (SDS = installation site specific spectral acceleration response)) | - | - | - | - | - |
| | | +P906 | Remote control board | - | - | - | ● | - |
| | | +P940 | Drive without front covers and cable entry box. Includes control panel. Note: With option +OJ400 does not include control panel holder cover. | - | - | - | - | - |
| | | +P944 | Version for cabinet mounting. Drive without cable entry box. | - | - | ● | - | - |
| | Cabling and pedestal | +OB051 | No IP20 shrouds for cabling area | - | - | - | - | - |
| | | +C135 | Drive for flange mounting. Removes the cable entry box. | - | - | ● | - | - |
| | | +C173 | Flat mounting – includes mounting brackets | - | - | - | - | - |
| | | +C217 | Wall mounting kit (to be used, if the module is mounted) | - | - | - | - | - |
| | | +H350 | Bottom entry | - | - | - | - | - |
| | | +H351 | Top entry | - | - | - | - | ● |
| | | +H352 | Bottom exit | - | - | - | - | - |
| | | +H353 | Top exit | - | - | - | - | ● |
| | | +H356 | DC connection busbars | - | - | - | - | - |
| | | +H358 | Cable conduit entry (US & UK version) | - | - | ● | - | ● |
| | | +H370 | Full size cable connection terminals for input AC power | - | - | - | ● | - |
| | | +H381 | Full power cabling panels to be attached to a cabinet. The drive module can be pulled out from the cabinet without disconnecting the power cables. IP20 degree of protection. | - | - | - | - | - |
| | | +H391 | Power cable terminals on the right-hand side | - | - | - | - | - |
| | | +OH354 | No pedestal | - | - | - | ● | - |
| | | +OH371 | No full size cable connection terminals for output power cables | - | - | - | ● | - |
| | +OP919 | No cabinet installation ramp | - | - | - | ● | - | |
| | Cabinet options | +G300 | Cabinet heater (External supply) | - | - | - | - | ● |
| | | +G301 | Cabinet lighting | - | - | - | - | - |
| | | +G307 | Terminals for External Control Voltage 230VAC or 115VAC (UPS) | - | - | - | - | ● |
| | | +G313 | Output for Motor heater (External supply) | - | - | - | - | - |
| | | +G327 | Ready Pilot light, white | - | - | - | - | ● |
| | | +G328 | Run Pilot light, green | - | - | - | - | ● |
| | | +G329 | Fault Pilot light, red | - | - | - | - | ● |
| | | +G330 | Halogen free wiring and materials | - | - | - | - | - |
| | | +G334 | V-meter with selector switch | - | - | - | - | - |
| | | +G335 | A-meter in one phase | - | - | - | - | - |
| | | +G340 | Wire marking class A3 | - | - | - | - | - |
| | | +G342 | Wire marking class C1 | - | - | - | - | - |

● = Available (standard, with plus code or ordering code)

| Basic codes | | | | | | | | | | | | | |
|-------------|----------------------|------------------------------|---|-----------|-----------|------------|--------------|-------------|-----------|--------------|--------------|--------------|---|
| Segment | Option | Code | Description | ACS880-01 | ACS880-04 | ACS880-04F | ACS880-04FXT | ACS880-04XT | ACS880-07 | ACS880-11/31 | ACS880-14/34 | ACS880-17/37 | |
| F | Resistor braking | +D150 | Braking chopper | ● | ● | ● | ● | ● | ● | - | - | ●*) | |
| | | +D151 | Braking resistor | - | - | - | - | - | ● | - | - | ● | |
| | Line options | +F250 | Line contactor | - | - | - | - | - | ● | - | - | - | |
| | | +F277 | Flange mounted switch for MCCB (Manufactured in US only) | - | - | - | - | - | ● | - | - | - | |
| | | +F278 | Main switch disconnecter (R1-R5) | - | - | - | - | - | - | - | - | - | |
| | | +F289 | Main case circuit breaker (UL listed, requires C129 option) | - | - | - | - | - | ● | - | - | - | |
| | Construction | +C121 | Marine construction | - | - | - | - | - | - | ● | - | - | ● |
| | | +C129 | Cabinet drive is UL listed | - | - | - | - | - | - | ● | - | - | ● |
| | | +C134 | CSA approved | - | - | - | - | - | - | ● | - | - | ● |
| | | +C180 | Seismic design | - | - | - | - | - | - | ● | - | - | ● |
| | | +C164 | Plinth height 100 mm | - | - | - | - | - | - | ● | - | - | ● |
| | | +C179 | Plinth height 200 mm | - | - | - | - | - | - | ● | - | - | ● |
| | | +C180 | Seismic design (Seismic capability according to International building code 2012, test procedure ICC-ES AC-156. Installation level 100% of the building height and SDS ≤ 2.0 g (SDS = installation site specific spectral acceleration response)) | - | - | - | - | - | - | - | - | - | - |
| | | +P906 | Remote control board | - | - | - | - | - | - | - | - | - | - |
| | | +P940 | Drive without front covers and cable entry box. Includes control panel. Note: With option +0J400 does not include control panel holder cover. | ● | - | - | - | - | - | - | ● | - | - |
| | | +P944 | Version for cabinet mounting. Drive without cable entry box. | ● | - | - | - | - | - | - | - | - | - |
| | Cabling and pedestal | +0B051 | No IP20 shrouds for cabling area | - | ● | - | ● | ● | ● | - | - | ● | - |
| | | +C135 | Drive for flange mounting. Removes the cable entry box. | ● | - | - | - | - | - | - | ● | - | - |
| | | +C173 | Flat mounting – includes mounting brackets | - | ● | - | - | ● | - | - | - | - | - |
| | | +C217 | Wall mounting kit (to be used, if the module is mounted) | - | - | ● | - | - | - | - | - | - | - |
| | | +H350 | Bottom entry | - | - | - | - | - | - | ● | - | - | ● |
| | | +H351 | Top entry | - | - | - | - | - | - | ● | - | - | ● |
| | | +H352 | Bottom exit | - | - | - | - | - | - | ● | - | - | ● |
| | | +H353 | Top exit | - | - | - | - | - | - | ● | - | - | ● |
| | | +H356 | DC connection busbars | - | ● | ● | ● | ● | ● | ● | - | - | - |
| | | +H358 | Cable conduit entry (US & UK version) | ● | - | - | - | - | - | ● | ● | - | ● |
| | | +H370 | Full size cable connection terminals for input AC power | - | ● | ● | ● | ● | ● | - | - | ● | - |
| | | +H381 | Full power cabling panels to be attached to a cabinet. The drive module can be pulled out from the cabinet without disconnecting the power cables. IP20 degree of protection. | - | ● | - | - | ● | - | - | - | ● | - |
| | | +H391 | Power cable terminals on the right-hand side | - | ● | - | - | ● | - | - | - | - | - |
| | | +0H354 | No pedestal | - | ● | - | - | - | - | - | - | - | - |
| | | +0H371 | No full size cable connection terminals for output power cables | - | ● | ● | ● | ● | ● | - | - | ● | - |
| | +0P919 | No cabinet installation ramp | - | ● | - | - | - | - | - | - | - | ● | |
| | Cabinet options | +G300 | Cabinet heater (External supply) | - | - | - | - | - | - | ● | - | - | ● |
| | | +G301 | Cabinet lighting | - | - | - | - | - | - | ● | - | - | ● |
| | | +G307 | Terminals for External Control Voltage 230VAC or 115VAC (UPS) | - | - | - | - | - | - | ● | - | - | ● |
| | | +G313 | Output for Motor heater (External supply) | - | - | - | - | - | - | ● | - | - | ● |
| | | +G327 | Ready Pilot light, white | - | - | - | - | - | - | ● | - | - | ● |
| | | +G328 | Run Pilot light, green | - | - | - | - | - | - | ● | - | - | ● |
| | | +G329 | Fault Pilot light, red | - | - | - | - | - | - | ● | - | - | ● |
| | | +G330 | Halogen free wiring and materials | - | - | - | - | - | - | ● | - | - | ● |
| | | +G334 | V-meter with selector switch | - | - | - | - | - | - | ● | - | - | ● |
| | | +G335 | A-meter in one phase | - | - | - | - | - | - | ● | - | - | ● |
| +G340 | | Wire marking class A3 | - | - | - | - | - | - | ● | - | - | ● | |
| +G342 | | Wire marking class C1 | - | - | - | - | - | - | ● | - | - | ● | |

● = Available (standard, with plus code or ordering code)

*) Only ACS880-37

| Basic codes | | | | | | | | |
|--------------------------------|---|-------------------------------------|--|-----------|-----------|-----------|-----------|-----------|
| Segment | Option | Code | Description | ACS380-04 | ACS480-04 | ACS580-01 | ACS580-04 | ACS580-07 |
| F | Language: Full set of printed manuals in selected language. Note: The delivered manual set may include manuals in English if the translation is not available. | +R700 | English | ● | ● | ● | ● | ● |
| | | +R701 | German | ● | ● | ● | ● | ● |
| | | +R702 | Italian | ● | ● | ● | ● | ● |
| | | +R703 | Dutch | ● | ● | ● | - | ● |
| | | +R704 | Danish | ● | ● | ● | - | ● |
| | | +R705 | Swedish | ● | ● | ● | - | ● |
| | | +R706 | Finnish | ● | ● | ● | - | ● |
| | | +R707 | French | ● | ● | ● | ● | ● |
| | | +R708 | Spanish | ● | ● | ● | ● | ● |
| | | +R709 | Portuguese (Portugal) | ● | ● | ● | - | ● |
| | | +R711 | Russian | ● | ● | ● | - | ● |
| | | +R712 | Chinese (available in China only) | ● | - | ● | ● | - |
| | | +R713 | Polish | ● | ● | ● | - | - |
| | | +R714 | Turkish | ● | ● | ● | - | - |
| | Software | +N2000 | Standard language package | - | - | ● | - | ● |
| | | +N2901 | Europe language package | - | - | ● | - | ● |
| | | +N2902 | Asia language package | - | - | ● | - | ● |
| | Starter for auxiliary Motor fan | +M600 | 1...1.6 A | - | - | - | - | ● |
| | | +M601 | 1.6...2.5 A | - | - | - | - | ● |
| | | +M602 | 2.5...4 A | - | - | - | - | ● |
| | | +M603 | 4...6.3 A | - | - | - | - | ● |
| | | +M604 | 6.3...10 A | - | - | - | - | ● |
| | | +M605 | 10...16 A | - | - | - | - | ● |
| | Specialities | +P902 | Customised (Described in eAppendix) | - | - | - | - | - |
| | | +P904 | Extended warranty, 24 months from commissioning or 30 months from delivery | - | - | - | - | - |
| | | +P909 | Extended warranty, 36 months from commissioning or 42 months from delivery | - | - | - | - | - |
| | | +P911 | Extended warranty (66 months from the delivery) | - | - | - | - | - |
| | | +P912 | Seaworthy Packing | - | - | - | - | ● |
| | | +P913 | Special colour, RAL CLASSIC-Classic colours | - | - | - | - | - |
| | | +P929 | Container Packing | - | - | - | - | ● |
| | | +P931 | Extended warranty up to 36 months | - | - | ● | ● | ● |
| | | +P932 | Extended warranty up to 60 months | - | - | ● | ● | ● |
| | | +P948 | Customized extended warranty, conditions agreed with factory case by case | - | - | - | - | - |
| | | +P952 | European Union Country of origin | - | - | ● | - | - |
| | | +P966 | Special colour, other than RAL CLASSIC-Classic colours | - | - | - | - | - |
| | | +C121 | Marine construction | - | - | - | - | - |
| | | +C131 | Vibration dampers | - | - | - | - | - |
| | | +C132 | Marine type approval (ABS, BV, CCS, DNV GL, LR or RS) | - | - | - | - | - |
| | | +C205 | Marine product certification DNV GL | - | - | - | - | - |
| | | +C206 | Marine product certification ABS | - | - | - | - | - |
| | | +C207 | Marine product certification Lloyd's register | - | - | - | - | - |
| | | +C208 | Marine product certification for RINA | - | - | - | - | - |
| | | +C209 | Marine product certification BV | - | - | - | - | - |
| +C210 | | Marine product certification for NK | - | - | - | - | - | |
| +C227 | Marine product certification for KR | - | - | - | - | - | | |
| +C228 | Marine product certification China classification society CCS | - | - | - | - | - | | |
| +C229 | Marine product certification Russian maritime register RS | - | - | - | - | - | | |
| Standard empty cabinets | +C196 | Empty cabinet 400 mm on right side | - | - | - | - | - | |
| | +C197 | Empty cabinet 600 mm on right side | - | - | - | - | - | |
| | +C198 | Empty cabinet 800 mm on right side | - | - | - | - | - | |
| | +C199 | Empty cabinet 400 mm on left side | - | - | - | - | - | |
| | +C200 | Empty cabinet 600 mm on left side | - | - | - | - | - | |
| | +C201 | Empty cabinet 800 mm on left side | - | - | - | - | - | |

● = Available (standard, with plus code or ordering code)

| Basic codes | | | | | | | | | | | | |
|-------------|---|--------|--|-----------|------------------|------------|--------------|-------------|-----------|--------------|--------------|--------------|
| Segment | Option | Code | Description | ACS880-01 | ACS880-04 | ACS880-04F | ACS880-04FXT | ACS880-04XT | ACS880-07 | ACS880-11/31 | ACS880-14/34 | ACS880-17/37 |
| | | | | F | Language: | +R700 | English | ● | ● | ● | ● | ● |
| | Full set of printed manuals in selected language. | +R701 | German | ● | ● | - | ● | ● | ● | ● | - | ● |
| | | +R702 | Italian | ● | ● | - | - | - | ● | ● | - | ● |
| | | +R703 | Dutch | ● | ● | - | - | - | ● | ● | - | ● |
| | Note: | +R704 | Danish | ● | ● | - | - | - | ● | ● | - | ● |
| | The delivered manual set may include manuals in English if the translation is not available. | +R705 | Swedish | ● | ● | - | - | - | ● | ● | - | ● |
| | | +R706 | Finnish | ● | ● | - | - | - | ● | ● | - | ● |
| | | +R707 | French | ● | ● | - | - | - | ● | ● | - | ● |
| | | +R708 | Spanish | ● | ● | - | - | - | ● | ● | - | ● |
| | | +R709 | Portuguese (Portugal) | ● | ● | - | - | - | ● | ● | - | ● |
| | | +R711 | Russian | ● | ● | - | - | - | ● | ● | - | ● |
| | | +R712 | Chinese (available in China only) | - | - | - | - | - | ● | - | - | - |
| | | +R713 | Polish | ● | ● | - | - | - | ● | ● | - | ● |
| | | +R714 | Turkish | ● | ● | - | - | - | - | ● | - | - |
| | Software | +N2000 | Standard language package | - | - | - | - | - | - | - | - | - |
| | | +N2901 | Europe language package | - | - | - | - | - | - | - | - | - |
| | | +N2902 | Asia language package | - | - | - | - | - | - | - | - | - |
| | Starter for auxiliary Motor fan | +M600 | 1...1.6 A | - | - | - | - | - | ● | - | - | ● |
| | | +M601 | 1.6...2.5 A | - | - | - | - | - | ● | - | - | ● |
| | | +M602 | 2.5...4 A | - | - | - | - | - | ● | - | - | ● |
| | | +M603 | 4...6.3 A | - | - | - | - | - | ● | - | - | ● |
| | | +M604 | 6.3...10 A | - | - | - | - | - | ● | - | - | ● |
| | | +M605 | 10...16 A | - | - | - | - | - | ● | - | - | ● |
| | Specialities | +P902 | Customised (Described in eAppendix) | - | - | - | - | - | ● | - | - | ● |
| | | +P904 | Extended warranty, 24 months from commissioning or 30 months from delivery | ● | ● | ● | ● | ● | ● | ● | ● | ● |
| | | +P909 | Extended warranty, 36 months from commissioning or 42 months from delivery | - | ● | ● | ● | ● | ● | ● | ● | ● |
| | | +P911 | Extended warranty (66 months from the delivery) | ● | ● | ● | ● | ● | ● | ● | ● | ● |
| | | +P912 | Seaworthy Packing | - | - | - | - | - | ● | - | - | ● |
| | | +P913 | Special colour, RAL CLASSIC-Classic colours | - | - | - | - | - | ● | - | - | ● |
| | | +P929 | Container Packing | - | - | - | - | - | - | - | - | - |
| | | +P931 | Extended warranty up to 36 months | - | - | - | - | - | - | - | - | - |
| | | +P932 | Extended warranty up to 60 months | - | - | - | - | - | - | - | - | - |
| | | +P948 | Customized extended warranty, conditions agreed with factory case by case | - | - | - | - | - | ● | - | - | ● |
| | | +P952 | European Union Country of origin | - | - | - | - | - | - | - | - | - |
| | | +P966 | Special colour, other than RAL CLASSIC-Classic colours | - | - | - | - | - | ● | - | - | ● |
| | | +C121 | Marine construction | - | - | - | - | - | ● | - | - | ● |
| | | +C131 | Vibration dampers | ● | - | - | - | - | - | - | - | - |
| | | +C132 | Marine type approval (ABS, BV, CCS, DNV GL, LR or RS) | ● | ● | - | - | ● | ● | - | - | ● |
| | | +C205 | Marine product certification DNV GL | ● | ● | - | - | - | ● | - | - | ● |
| | | +C206 | Marine product certification ABS | ● | ● | - | - | - | ● | - | - | ● |
| | | +C207 | Marine product certification Lloyd's register | ● | ● | - | - | - | ● | - | - | ● |
| | | +C208 | Marine product certification for RINA | ● | ● | - | - | - | - | - | - | - |
| | | +C209 | Marine product certification BV | ● | ● | - | - | ● | ● | - | - | ● |
| | | +C210 | Marine product certification for NK | ● | ● | - | - | - | - | - | - | - |
| | | +C227 | Marine product certification for KR | ● | ● | - | - | - | - | - | - | - |
| | | +C228 | Marine product certification China classification society CCS | ● | ● | - | - | - | ● | - | - | ● |
| | | +C229 | Marine product certification Russian maritime register RS | ● | ● | - | - | - | ● | - | - | ● |
| | Standard empty cabinets | +C196 | Empty cabinet 400 mm on right side | - | - | - | - | - | ● | - | - | ● |
| | | +C197 | Empty cabinet 600 mm on right side | - | - | - | - | - | ● | - | - | ● |
| | | +C198 | Empty cabinet 800 mm on right side | - | - | - | - | - | ● | - | - | ● |
| | | +C199 | Empty cabinet 400 mm on left side | - | - | - | - | - | ● | - | - | ● |
| | | +C200 | Empty cabinet 600 mm on left side | - | - | - | - | - | ● | - | - | ● |
| | | +C201 | Empty cabinet 800 mm on left side | - | - | - | - | - | ● | - | - | ● |

● = Available (standard, with plus code or ordering code)



Customizing drives

Adding value to machine building

Your customers expect the machines they order from you to be specifically adapted for their needs. To support you in doing this, we offer customizing solutions to make this

happen, with either you or ABB doing the customizing work. All of these customized services focus on speeding up your work, whether it concerns programming or device handling.

Customizing for individual needs

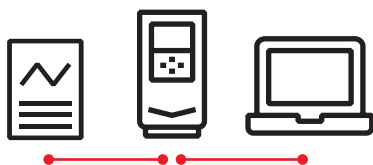

For quicker access to the drive, we can customize menus, parameters and macros on the drive control panel or PC tool interface using ABB's Drive customizing software suite. Once menus, parameters and macros have been personalized, they can be protected using differentiated access levels via passcodes, depending on the user.

Speaking your language



To increase understandability and ease-of-use, the drive customizer makes it possible to rapidly program the drive to speak the language of the application it is controlling. This serves to speed up the use and operation of the drive, again resulting in savings in time and money.

Preconfigure your drive before start-up

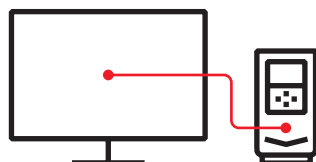

To speed up your actual machine assembly and commissioning, customization can be loaded into a drive before the drive is started up.

Customization can contain parameter settings and views. This can be done either with the cold configuration adapter (CCA-01) or preconfigured memory units.

Memory unit

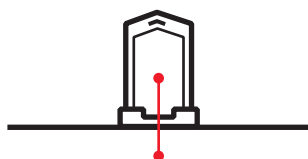

A memory unit is a detachable device containing the software and settings of the drive.

Customizing options

| Description | ACS380 | ACS480 | ACS580 | ACS880 |
|------------------------|--------|--------|--------|--------|
| Individual customizing | • | • | • | • |
| Language customizing | • | • | • | • |
| Preconfiguration | • | • | • | - |
| Memory unit | - | - | - | • |

We keep your world turning

Whatever your needs are, we offer the most extensive service offering for drives, motors and generators from spare parts and technical support to cloud-based condition monitoring solutions to keep your equipment running.

The global ABB service units complemented by external Value Providers form a service network on your doorstep. Maximize performance, uptime and efficiency throughout the life cycle of your assets.

With you every step of the way

Even before you buy a generator, drive, motor, bearing or softstarter, ABB's experts are on hand to offer technical advice from dimensioning through to potential energy saving.

When you've decided on the right product, ABB and its global network of Value Providers can help with installation and commissioning. They are also on hand to support you throughout the operation and maintenance phases of the products life cycle, providing maintenance programs tailored to your facility's needs.

ABB will ensure you are aware of any service opportunities. If you've registered your drives and motors with ABB, then its engineers will proactively contact you advising on your most effective service options. All of which helps maximize performance, uptime and efficiency throughout the lifetime of your powertrain.

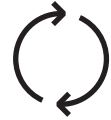

Replacements
Fast and efficient replacement services to minimize production downtime.



End-of-life services
Responsible dismantling, recycling and reusing of products, according to local laws and industrial standards.



Maintenance
Systematic and organized maintenance and support over the life cycle of your assets.





Advanced services

Gain the unique ABB Ability™ digital advantage through data collection and analytics with advanced services.



Extensions, upgrades & retrofits

Up-to-date systems and devices with the best possible performance level.



Engineering & consulting

Ways to identify and improve the reliability, usability, maintainability and safety of your production processes.



Spares & consumables

Authentic, high-quality ABB spares and consumables with quick delivery.



Technical support & repairs

Quick and accurate response during emergencies and efficient support during planned production breaks.



Installation & commissioning

Highly-trained and reliable installation and commissioning experts at your service.



Training

Comprehensive and professional training either at ABB premises or your own.



Agreements

Comprehensive bundling of relevant services into one contract to suit your needs.

Global service network 24/7

—
“I need operational excellence, rapid response, improved performance and life cycle management.”

ABB Drives Life Cycle Management

A life time of peak performance

You're in control of every life cycle phase of your drives. At the heart of drive services is a four-phase product life cycle management model. This model defines the services recommended and available throughout drives lifespan.

Now it's easy for you to see the exact service and maintenance available for your drives.

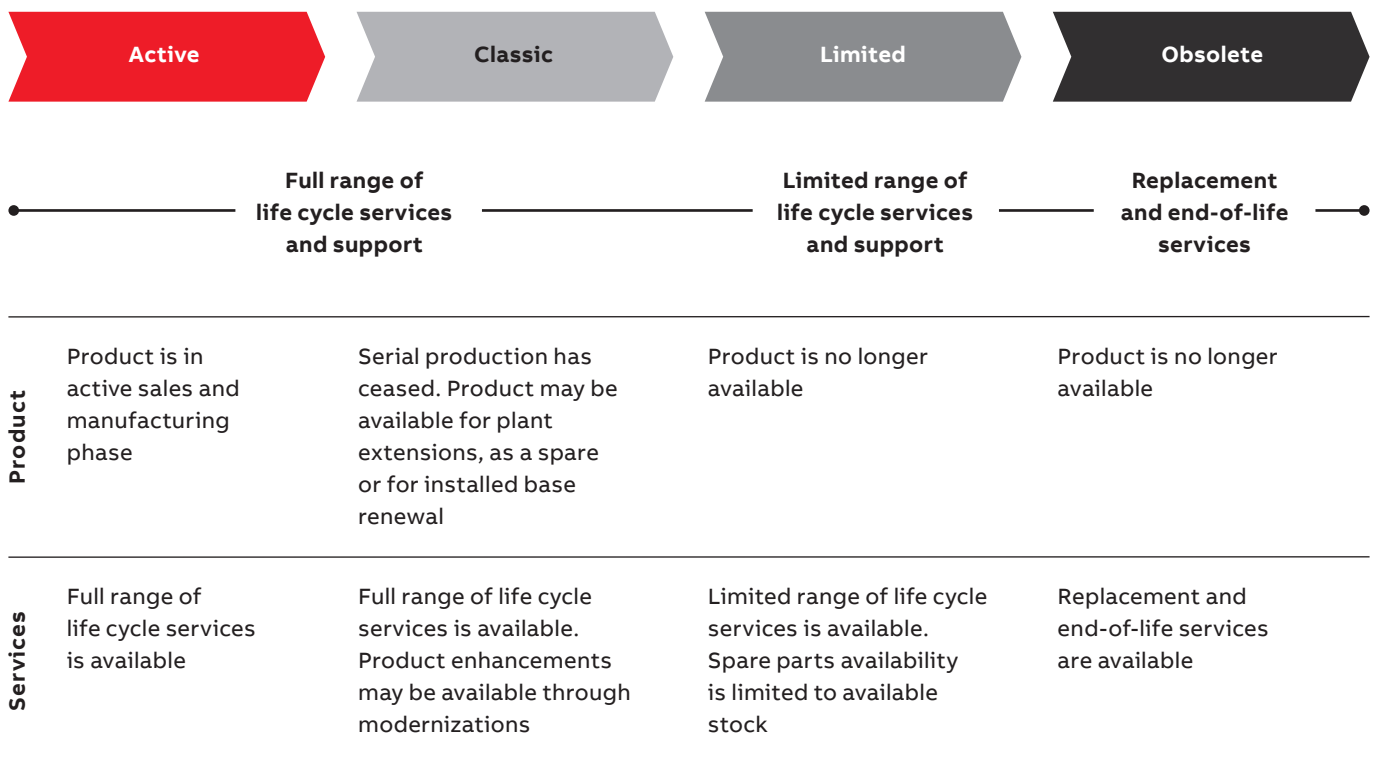



Keeping you informed throughout the life cycle

We notify you every step of the way using life cycle status statements and announcements.

Your benefit is clear information about your drives' status and precise services available. It helps you plan the preferred service actions ahead of time and make sure that continuous support is always available.

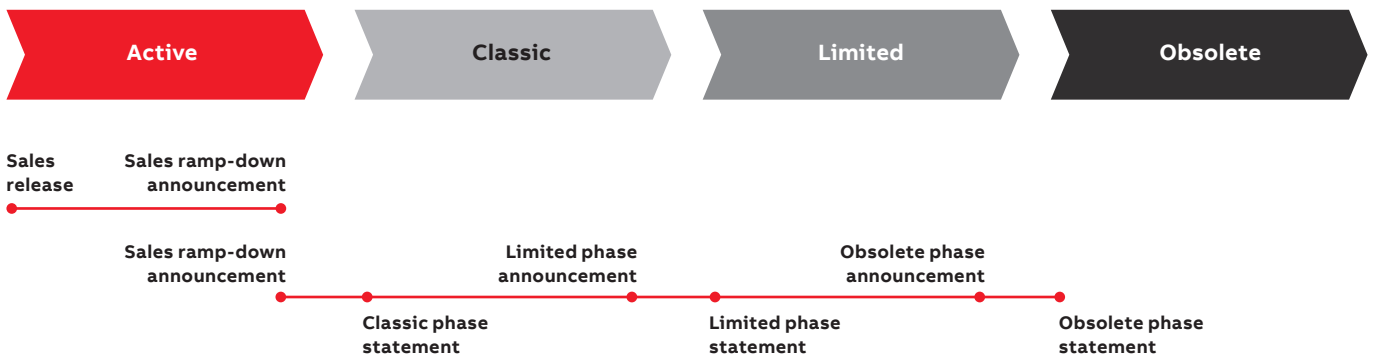

Sales release

Details about product portfolio and release schedule.

Sales ramp down announcement

Last time buy and last deliveries dates, informed well in advance.

Life cycle phase change announcement

Early information about the upcoming life cycle phase change and affects on the service availability. Informed well in advance, minimum six months prior to the change.

Life cycle phase statement

Information about the current life cycle status, product and services availability and recommended actions. Plan for the next life cycle phase transition.

Additional information

We reserve the right to make technical changes or modify the contents of this document without prior notice. With regard to purchase orders, the agreed particulars shall prevail. ABB does not accept any responsibility whatsoever for potential errors or possible lack of information in this document.

We reserve all rights in this document and in the subject matter and illustrations contained therein. Any reproduction, disclosure to third parties or utilization of its contents – in whole or in parts – is forbidden without prior written consent of ABB.



—
For more information, please contact
your local ABB representative or visit

new.abb.com/drives
new.abb.com/drives/drivespartners
new.abb.com/motors-generators
new.abb.com/plc

—
For other product documents

www.abb.com/drives/documents